

## AIR TREATMENT MODULES

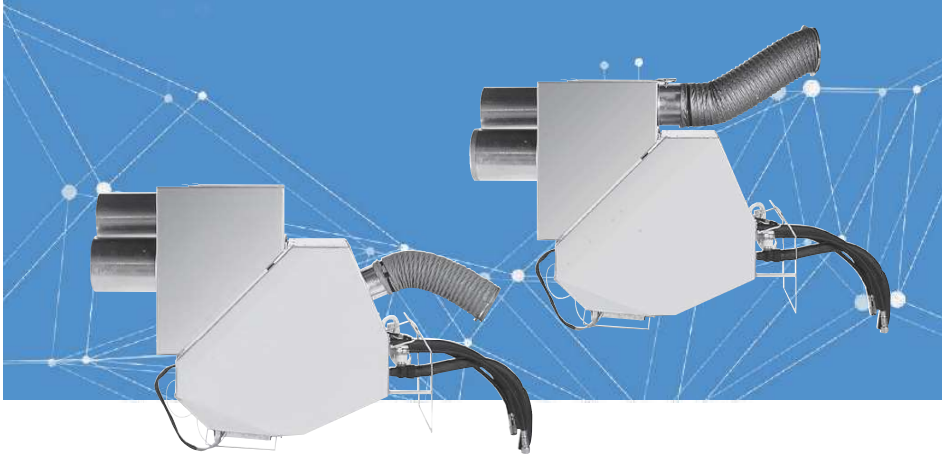

### 42GR



Two sizes with two-pipe plus electric heater or four-pipe coils, with an air flow range from 103 to 109 l/s, a cooling capacity of 3.1 kW and a heating capacity range from 2.9 to 3.5 kW.

Decentralised compact ducted chilled-water fan coil system, designed for installation in plant rooms. This allows centralised service and maintenance.

Reliable and efficient heating and cooling for office blocks and institutional buildings.

The LEC (low energy consumption) fan motor assembly is available as standard. This direct-drive motor is electronically commutated (EC motor), controlled by a 0–10 V signal and allows precise, simple and quiet unit operation in a wide range of rotational speeds in variation from the original speed.

## PHYSICAL DATA

42GR	1.9			2.9			
	L	M	H	L	M	H	
<b>Fan speed *</b>							
<b>Variable Speed</b>	V	4	6	10	4	6	10
Air Flow Rate	l/s	44	70	100	52	88	123
	m <sup>3</sup> /h	160	250	360	187	316	441
External Static Pressure	Pa	64	151	310	57	164	320
<b>Cooling Mode **</b>							
Total cooling capacity	kW	1,32	1,86	2,36	1,67	2,65	3,44
Sensible cooling capacity	kW	0,92	1,33	1,72	1,13	1,81	2,37
Water flow rate	l/h	230	330	430,0	290	460	610
	l/s						
Water pressure drop	kPa	7	12,9	19,9	4	8,5	13,4
<b>Two-pipe heating Mode ***</b>							
Heating capacity	kW	1,32	1,95	2,65	1,49	2,39	3,16
Water flow rate	l/h	230	340	460	260	420	550
	l/s						
Water pressure drop	kPa	6,6	12,2	20,3	3,7	7,2	11,1
Water content	l		0,83			1,5	
<b>Four-pipe heating Mode ****</b>							
Heating capacity	kW	1,44	1,92	2,39	1,86	2,76	3,45
Water flow rate	l/h	130	170	210	160	240	300
	l/s						
Water pressure drop	kPa	2,5	3,6	4,7	4,4	7,8	11,2
Water content	l		0,17				
<b>Electrical heater</b>		1 ph - 50 Hz - 230 V					
Maximum capacity	kW		1,7			1,8	
Maximum current drawn	A		11			11	
<b>Sounds levels</b>							
Lw (global): Sound power level	dB(A)	45	57	65	51	60	66
Lw (inlet + radiated): Sound power level	dB(A)	41	50	59	49	58	64
Lw (outlet): Sound power level	dB(A)	43	56	64	46	55	61
Lp (global): Sound pressure level ‡	dB(A)	28	40	48	34	43	49
NC level ‡	dB(A)	24	36	44	29	36	43
NR level ‡	dB(A)	26	38	46	31	38	45
<b>Electrical data, motor</b>		1 ph - 50 Hz - 230 V ; type EC low energy consumption					
Power input	W	15	42	113	16	56	137
<b>Air filter F5 or F6</b>	mm	225 x 350			395 x 350		
<b>Physical data</b>							
Connection diameter, chilled and hot-water coil	in	1/2" gaz			1/2" gaz		
Length (standard)	mm	960			960		
Height (standard)	mm	962			962		
Depth (standard)	mm	250			420		
Unit weight (standard)	kg	35			50		

\* Fan speed: L= Low, M: Medium, H=High

\*\* Cooling mode: Entering air temperature 27°C/47% rh, entering/leaving water temperature 7°C/12°C

\*\*\* Heating mode (2 pipe): Entering air temperature 20°C, entering/leaving water temperature 45°C/40°C.

\*\*\*\* Heating mode (4 pipe): Entering air temperature 20°C, entering/leaving water temperature 65°C/55°C

‡ Based on an hypothetical attenuation for the room and the air distribution system of -17dB(A)

## COOLING CAPACITIES, KW

### 42GR19

Water temperatures (°C) Inlet - Outlet		Relative Humidity 50 %														
		Air flow rate l/s (m³/h)														
		28 (100)			56 (200)			83 (300)			97 (350)			111 (400)		
		Dry bulb Air Temperature inlet (°C)														
		27	25	23	27	25	23	27	25	23	27	25	23	27	25	23
6 - 12	TC	0.94	0.78	0.64	1.70	1.40	1.10	2.32	1.91	1.51	2.60	2.13	1.69	2.85	2.34	1.86
	SHC	0.61	0.55	0.49	1.14	1.01	0.89	1.60	1.42	1.26	1.81	1.61	1.43	2.01	1.79	1.59
	TSA	8.7	8.7	8.5	9.9	9.9	9.8	11.0	10.8	10.5	11.4	11.2	10.8	11.9	11.6	11.2
	DE	134	112	91	243	200	157	332	273	216	371	305	242	407	335	266
7 - 12	TC	0.91	0.75	0.60	1.66	1.36	1.07	2.27	1.87	1.47	2.54	2.09	1.65	2.78	2.29	1.82
	SHC	0.60	0.53	0.47	1.12	1.00	0.88	1.58	1.41	1.24	1.79	1.59	1.41	1.98	1.77	1.57
	TSA	9.1	9.1	9.1	10.2	10.1	10.0	11.2	11.0	10.7	11.7	11.4	11.0	12.1	11.8	11.3
	DE	156	129	102	284	234	183	390	322	252	436	360	283	478	394	312
8 - 13	TC	0.83	0.67	0.53	1.51	1.22	0.94	2.08	1.67	1.30	2.32	1.88	1.46	2.54	2.07	1.62
	SHC	0.56	0.50	0.44	1.06	0.93	0.82	1.50	1.32	1.16	1.69	1.50	1.33	1.88	1.67	1.48
	TSA	10.1	10.2	9.9	11.1	11.1	10.8	12.0	11.8	11.4	12.5	12.2	11.7	12.9	12.5	12.0
	DE	143.3	116	92	260	209	161	357	288	223	398	322	252	436	356	279
10 - 15	TC	0.67	0.54	0.42	1.21	0.95	0.73	1.67	1.31	1.03	1.87	1.48	1.17	2.06	1.64	1.30
	SHC	0.49	0.44	0.39	0.93	0.82	0.72	1.32	1.16	1.02	1.51	1.32	1.16	1.68	1.48	1.29
	TSA	12.2	12.0	11.4	13.0	12.8	12.3	13.7	13.4	12.8	14.0	13.6	13.1	14.3	13.9	13.3
	DE	115	92	71	208	163	126	287	226	178	322	254	201	354	282	224

### 42GR29

Water temperatures (°C) Inlet - Outlet		Relative Humidity 50 %																	
		Air flow rate l/s (m³/h)																	
		28 (100)			56 (200)			83 (300)			111 (400)			139 (500)			167 (600)		
		Dry bulb Air Temperature inlet (°C)																	
		27	25	23	27	25	23	27	25	23	27	25	23	27	25	23	27	25	23
6 - 12	TC	1.03	0.88	0.72	1.95	1.64	1.30	2.81	2.34	1.86	3.58	2.98	2.37	4.28	3.57	2.84	4.91	4.10	3.28
	SHC	0.65	0.59	0.53	1.26	1.12	0.99	1.83	1.63	1.44	2.36	2.11	1.86	2.86	2.56	2.26	3.32	2.98	2.65
	TSA	7.1	7.2	7.3	7.9	8.1	8.2	8.5	8.7	8.7	9.1	9.1	9.1	9.7	9.6	9.5	10.2	10.1	9.8
	DE	147	126	103	279	234	186	401	335	266	513	427	339	612	510	406	702	587	469
7 - 12	TC	0.98	0.83	0.67	1.88	1.57	1.24	2.71	2.25	1.78	3.46	2.88	2.27	4.14	3.44	2.72	4.76	3.96	3.15
	SHC	0.63	0.57	0.50	1.22	1.09	0.96	1.78	1.59	1.40	2.31	2.06	1.82	2.80	2.50	2.21	3.26	2.91	2.59
	TSA	7.9	8.0	8.0	8.4	8.6	8.7	9.0	9.1	9.1	9.5	9.5	9.4	10.0	10.0	9.8	10.6	10.4	10.1
	DE	168	142	115	323	269	213	466	387	305	595	494	390	711	591	468	818	679	541
8 - 13	TC	0.90	0.76	0.60	1.73	1.41	1.09	2.48	2.03	1.57	3.17	2.59	2.00	3.78	3.11	2.41	4.34	3.57	2.78
	SHC	0.60	0.53	0.47	1.15	1.02	0.89	1.68	1.49	1.30	2.18	1.93	1.69	2.64	2.35	2.07	3.08	2.74	2.42
	TSA	9.0	9.0	9.0	9.5	9.7	9.7	10.0	10.1	10.0	10.5	10.5	10.3	11.0	10.9	10.7	11.5	11.2	11.0
	DE	155.4	130	103	297	243	188	427	349	269	544	445	344	650	534	413	747	613	477
10 - 15	TC	0.75	0.60	0.46	1.41	1.11	0.84	2.02	1.59	1.20	2.57	2.02	1.54	3.08	2.43	1.87	3.54	2.80	2.18
	SHC	0.53	0.46	0.41	1.01	0.89	0.78	1.48	1.30	1.14	1.93	1.69	1.48	2.34	2.06	1.81	2.74	2.41	2.13
	TSA	11.0	11.0	10.8	11.6	11.7	11.4	12.0	12.0	11.7	12.4	12.3	11.9	12.8	12.6	12.2	13.2	12.9	12.4
	DE	129	104	79	242	190	144	347	273	206	443	348	266	530	418	322	609	482	375

**Legend:**

TC - Total cooling capacity, kW  
 SHC - Sensible heat capacity, kW  
 TSA - Air discharge temperature, °C  
 WF - Water flow, l/s

## OPTIONS/ACCESSORIES

- Custom-made product on request

## FEATURES AND ADVANTAGES

- Two sizes with two-pipe plus electric heater or four-pipe coils, with an air flow range from 103 to 109 l/s, a cooling capacity of 3.1 kW and a heating capacity range from 2.9 to 3.5 kW.
- Decentralised compact ducted chilled-water fan coil system, designed for installation in plant rooms. This allows centralised service and maintenance.
- Reliable and efficient heating and cooling for office blocks and institutional buildings.
- High efficiency EU6 filter.
- Extremely low sound level.
- The LEC (low energy consumption) fan motor assembly is available as standard. This direct-drive motor is electronically commutated (EC motor), controlled by a 0–10 V signal and allows precise, simple and quiet unit operation in a wide range of rotational speeds in variation from the original speed.
- High-pressure centrifugal fans, compatible with air diffusion systems up to 300 Pa.
- Compatible with the 35BD air diffuser range.
- Safe factory-installed electric heater for single or two-stage hot water heating.
- Available with demand control ventilation (DCV) and CO<sub>2</sub> sensor.
- Can be equipped with a UV-PCO IAQ module.
- Low hydraulic pressure drop with a valve mounted, compatible with all chiller pump kits.
- Quick installation with factory-installed options (controls, valves).
- Available with NTC controller (Aquasmart Evolution) or WTC controller (LON or BACNET)

### 35BD linear diffuser (supply and return air)



## ELECTRICAL DATA

### 42GR19

Control (Volts)	I (A)	Cos	Puis. (W)	Qv	Qv	P (Pa)
				(m <sup>3</sup> /h)	(l/s)	
10V	0.90	0.54	112	492	137	2
	0.90	0.54	112	447	124	106
	0.91	0.53	112	397	110	232
	0.90	0.53	111	351	97	327
	0.91	0.53	112	303	84	418
	0.90	0.54	112	254	71	497
9V	0.80	0.53	98	197	55	560
	0.90	0.54	112	489	136	3
	0.90	0.54	111	448	125	98
	0.90	0.54	112	399	111	224
	0.92	0.53	112	349	97	330
	0.85	0.53	103	301	84	387
	0.78	0.52	93	249	69	413
	0.70	0.51	82	201	56	449
8V	0.61	0.50	71	154	43	485
	0.92	0.53	112	489	136	2
	0.92	0.53	111	449	125	93
	0.84	0.52	101	397	110	184
	0.77	0.51	91	349	97	239

Control (Volts)	I (A)	Cos	Puis. (W)	Qv	Qv	P (Pa)
				(m <sup>3</sup> /h)	(l/s)	
8V	0.70	0.51	81	301	83	285
	0.63	0.50	72	249	69	319
	0.57	0.49	63	198	55	345
	0.50	0.48	55	152	42	374
7V	0.75	0.51	88	450	125	1
	0.68	0.50	80	399	111	78
	0.62	0.49	70	350	97	141
	0.56	0.49	62	301	84	188
	0.49	0.48	54	249	69	227
	0.43	0.47	48	198	55	251
6V	0.38	0.47	41	154	43	276
	0.34	0.46	36	110	31	298
	0.48	0.55	60	390	108	6
	0.44	0.54	55	350	97	59
	0.39	0.54	48	300	83	112
5V	0.34	0.54	42	249	69	157
	0.30	0.53	36	202	56	181
	0.25	0.52	30	151	42	194
	0.22	0.52	26	101	28	221
	0.30	0.53	37	324	90	2
5V	0.29	0.52	35	302	84	28
	0.25	0.51	29	249	69	74

#### legend:

V - Fan motor control voltage supply

## ELECTRICAL DATA

### 42GR19

Control (Volts)	I (A)	Cos	Puis. (W)	Qv	Qv	P (Pa)
				(m³/h)	(l/s)	
5V	0.22	0.50	25	201	56	103
	0.19	0.48	21	142	39	123
	0.17	0.45	18	102	28	143
4V	0.18	0.51	21	256	71	3
	0.15	0.50	17	199	55	46
	0.13	0.49	15	149	41	72
	0.11	0.48	13	104	29	82
	0.10	0.48	11	66	18	98

legend:

V - Fan motor control voltage supply

### 42GR29

Control (Volts)	I (A)	Cos	Puis. (W)	Qv (m³/h)	Qv (l/s)	P (Pa)
10V	1.44	0.55	179	806	224	2
	1.39	0.55	172	763	212	52
	1.37	0.53	165	728	202	94
	1.34	0.54	162	695	193	126
	1.31	0.52	159	590	164	224
	1.29	0.51	150	527	147	271
	1.21	0.53	146	497	138	290
	1.15	0.54	141	459	128	305
	1.02	0.54	128	374	104	352
	0.96	0.52	113	320	89	369
0.78	0.52	94	183	51	406	
9V	1.24	0.51	150	754	209	4
	1.24	0.52	148	716	199	47
	1.18	0.55	147	676	188	92
	1.07	0.53	140	621	173	151
	1.17	0.56	136	562	156	200
	1.05	0.54	127	511	142	239
	1.02	0.55	123	436	121	278
	0.86	0.54	108	373	104	307
	0.74	0.52	89	260	72	335
	0.68	0.52	82	186	52	350
8V	0.81	0.53	101	658	183	0
	0.81	0.53	101	605	168	62
	0.85	0.52	101	557	155	108
	0.86	0.54	105	506	140	153
	0.82	0.56	99	454	126	184
	0.73	0.54	90	404	112	209
	0.67	0.50	81	350	97	236
	0.60	0.52	69	302	84	249
	0.56	0.49	64	253	70	257
	0.48	0.56	56	158	44	273
7V	0.57	0.52	69	563	156	0
	0.56	0.55	69	517	144	48
	0.55	0.52	67	478	133	71
	0.57	0.49	71	431	120	115

legend:

V - Fan motor control voltage supply

Control (Volts)	I (A)	Cos	Puis. (W)	Qv	Qv	P (Pa)
				(m³/h)	(l/s)	
3V	0.11	0.45	11	184	51	0
	0.10	0.42	10	151	42	20
3V	0.09	0.41	8	106	29	38
	0.07	0.40	7	48	13	53
2V	0.06	0.39	5	106	29	2
	0.06	0.39	5	83	23	10
	0.05	0.38	4	33	9	22

Control (Volts)	I (A)	Cos	Puis. (W)	Qv (m³/h)	Qv (l/s)	P (Pa)
7V	0.52	0.55	63	366	102	145
	0.45	0.53	51	301	84	168
	0.41	0.52	47	252	70	180
	0.39	0.51	45	201	56	188
	0.35	0.49	40	160	45	193
	0.33	0.46	36	124	35	195
	0.36	0.49	39	455	126	0
6V	0.35	0.48	39	395	110	45
	0.35	0.53	40	354	98	72
	0.31	0.53	33	298	83	91
	0.29	0.49	32	254	71	104
	0.26	0.73	28	198	55	113
	0.23	1.00	25	151	42	120
5V	0.21	1.00	23	119	33	123
	0.22	0.91	23	352	98	0
	0.21	1.00	21	300	83	25
	0.18	1.00	19	252	70	42
4V	0.17	1.00	17	201	56	54
	0.15	1.00	14	142	40	65
	0.14	1.00	12	95	26	69
	0.13	1.00	12	67	19	72
	0.16	1.00	15	290	80	1
	0.14	1.00	15	249	69	20
3V	0.14	1.00	14	205	57	32
	0.13	1.00	12	150	42	43
	0.12	1.00	10	110	31	49
	0.13	1.00	10	82	23	52
	0.11	1.00	8	200	55	1
	0.10	1.00	8	184	51	4
	0.09	1.00	7	140	39	16
2V	0.10	1.00	7	101	28	21
	0.09	1.00	7	86	24	22
	0.07	1.00	4	106	29	1
2V	0.06	1.00	2	74	21	5
	0.07	1.00	4	45	12	8



## AIR FLOW/AVAILABLE STATIC PRESSURE DATA

42GR19

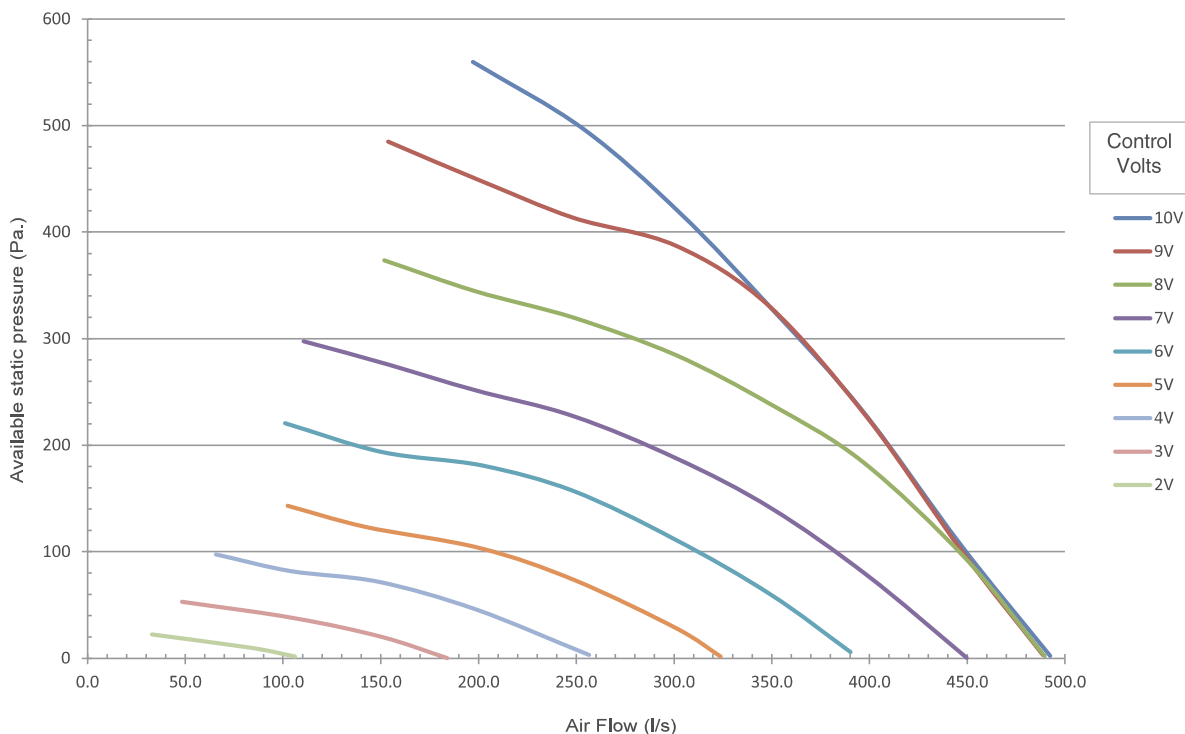

42GR29

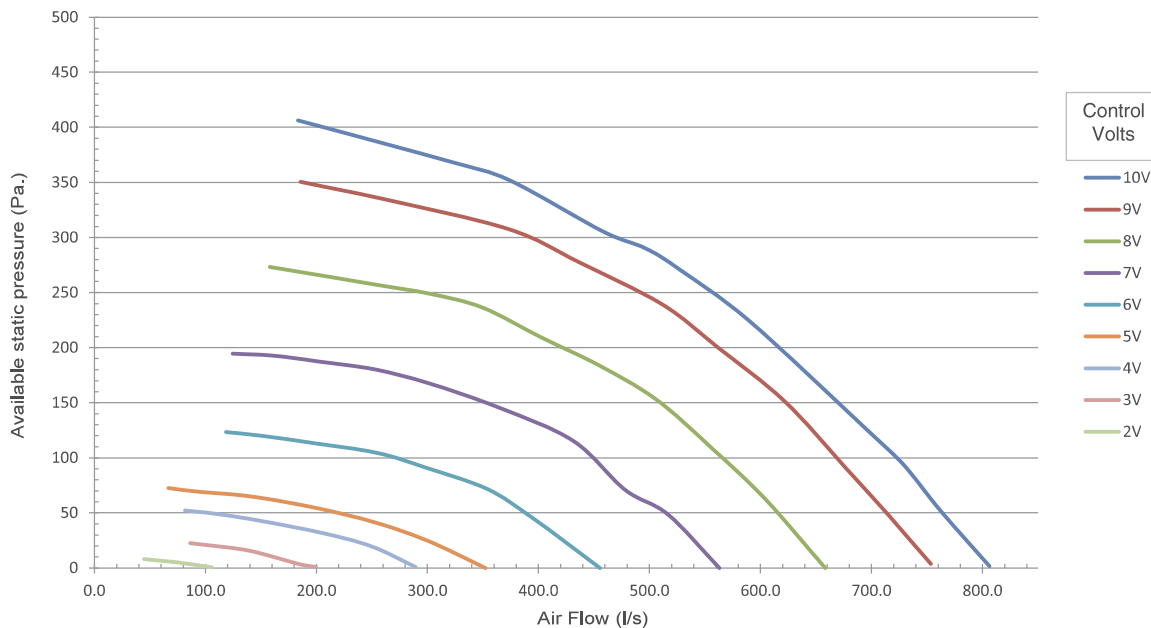

legend:  
V - Fan motor control voltage supply

## SOUND POWER LEVEL

### 42GR19

Volts	Type	Octave band frequency (Hz)						
		125	250	500	1K	2K	4K	dB(A)
10V	SUP	49	51	47	60	60	54	64
	RET	39	43	41	46	49	39	52
	RAD	50	48	51	55	53	46	58
9V	SUP	48	51	46	59	58	52	62
	RET	39	42	40	47	46	38	51
	RAD	47	47	50	54	51	45	57
8V	SUP	47	50	45	58	56	51	61
	RET	38	42	39	48	44	37	50
	RAD	48	47	49	53	50	44	56
7V	SUP	44	47	43	56	51	47	58
	RET	35	38	36	43	39	32	45
	RAD	46	43	47	50	45	40	53
6V	SUP	41	43	40	54	46	42	56
	RET	31	34	33	38	34	28	41
	RAD	44	40	44	47	41	35	49
5V	SUP	36	39	36	48	40	38	49
	RET	26	29	30	34	27	24	36
	RAD	39	36	41	42	36	33	45
4V	SUP	32	34	32	41	34	32	43
	RET	22	23	26	31	21	20	32
	RAD	34	32	37	38	31	29	41
3V	SUP	28	30	28	35	28	27	37
	RET	17	20	23	27	17	16	29
	RAD	30	28	33	34	26	24	37
2V	SUP	25	28	26	32	25	23	34
	RET	15	18	20	25	15	15	27
	RAD	27	25	30	31	22	20	33

### 42GR29

Volts	Type	Octave band frequency (Hz)						
		125	250	500	1K	2K	4K	dB(A)
10V	SUP	66	64	60	50	46	52	61
	RET	66	54	53	48	50	45	57
	RAD	61	56	56	58	58	51	63
	SUP	65	62	58	48	45	50	60
9V	RET	65	52	51	47	48	43	55
	RAD	60	55	54	57	56	49	62
	SUP	64	60	57	47	43	48	58
8V	RET	63	50	49	45	46	41	53
	RAD	59	54	53	56	54	46	60
	SUP	61	57	53	44	38	43	55
7V	RET	61	48	47	44	43	38	51
	RAD	56	50	50	54	51	42	57
	SUP	58	53	49	42	34	38	51
6V	RET	59	45	45	42	39	34	48
	RAD	54	47	48	52	47	37	54
	SUP	54	48	44	38	26	29	46
5V	RET	54	39	39	36	30	-	42
	RAD	49	41	42	47	39	-	49
	SUP	49	43	38	34	18	20	40
4V	RET	49	34	32	30	21	-	36
	RAD	45	36	36	42	31	-	43
	SUP	41	36	33	28	16	-	34
3V	RET	43	31	30	28	18	-	30
	RAD	36	30	31	34	27	-	37
	SUP	34	29	27	22	14	-	28
2V	RET	38	29	28	26	15	-	23
	RAD	28	24	25	26	23	-	30

**Legend:**

V - Fan motor control voltage supply    SUP - Supply (dB re = 10-12 W)    RET - Return (dB re = 10-12 W)    RAD - Radiated (dB re = 10-12 W)



# ELECTRICAL HEATER PERFORMANCES

42GR Size 19

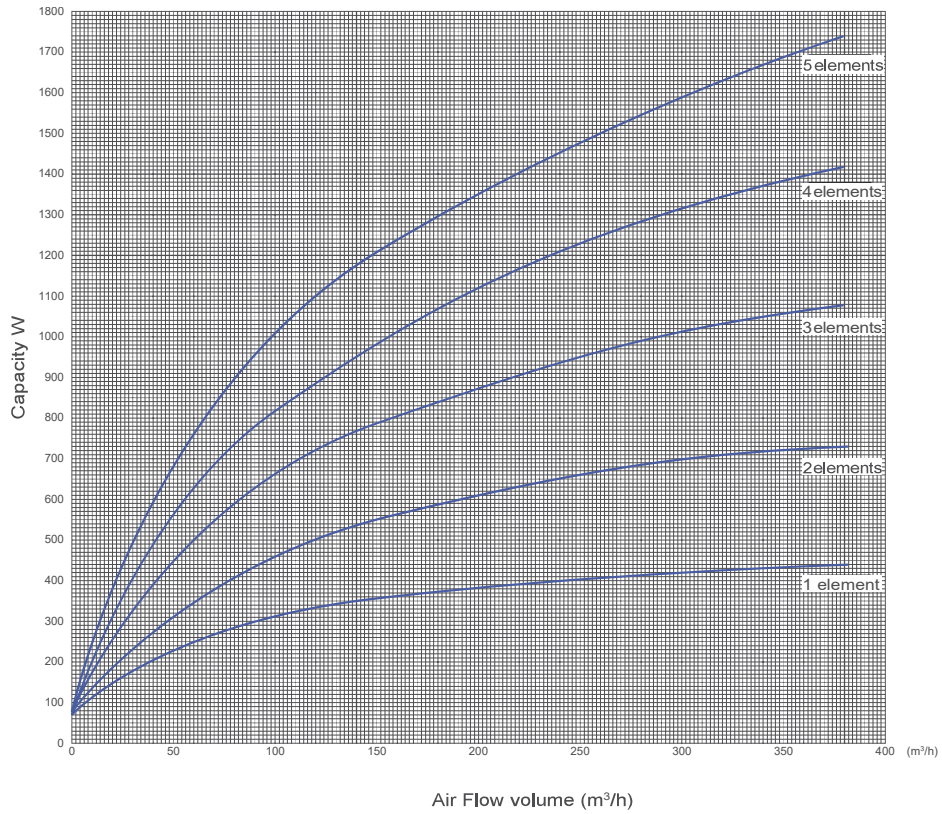

42GR Size 29

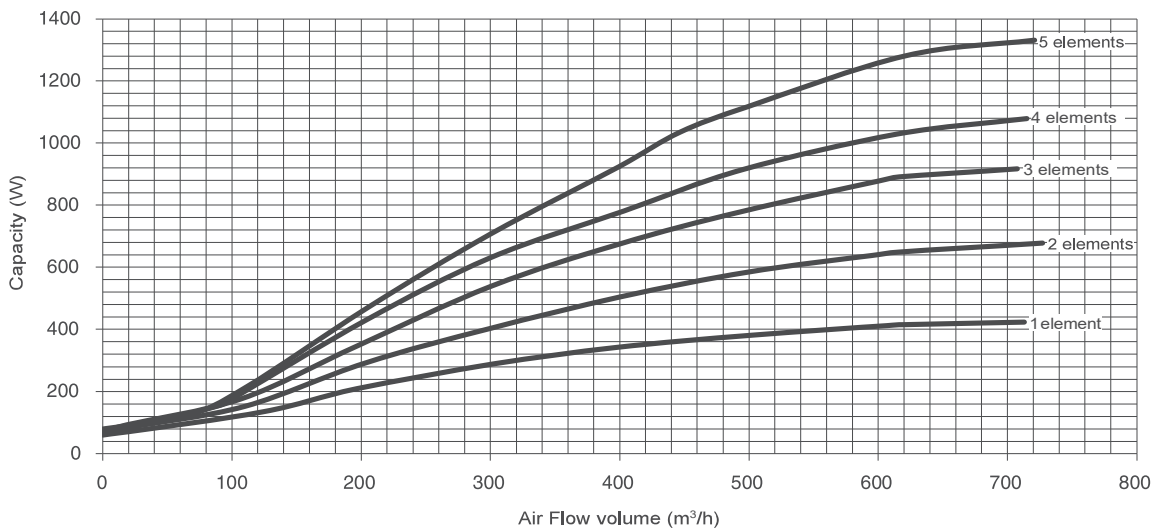



**DIMENSIONS/CLEARANCES, MM**

**Standard installation**

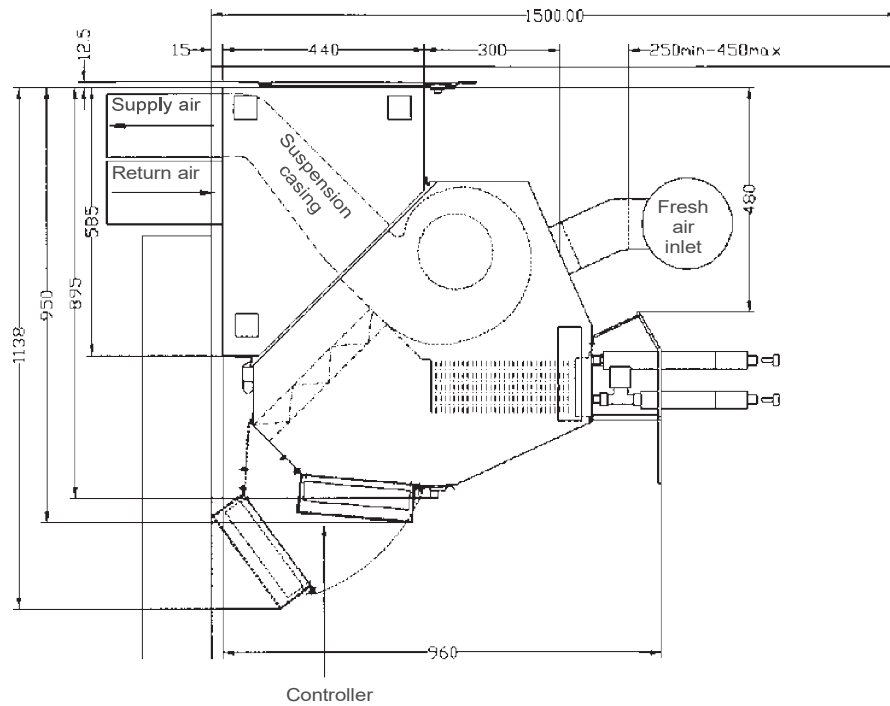

**Air distribution with Optimix linear diffusers**

