

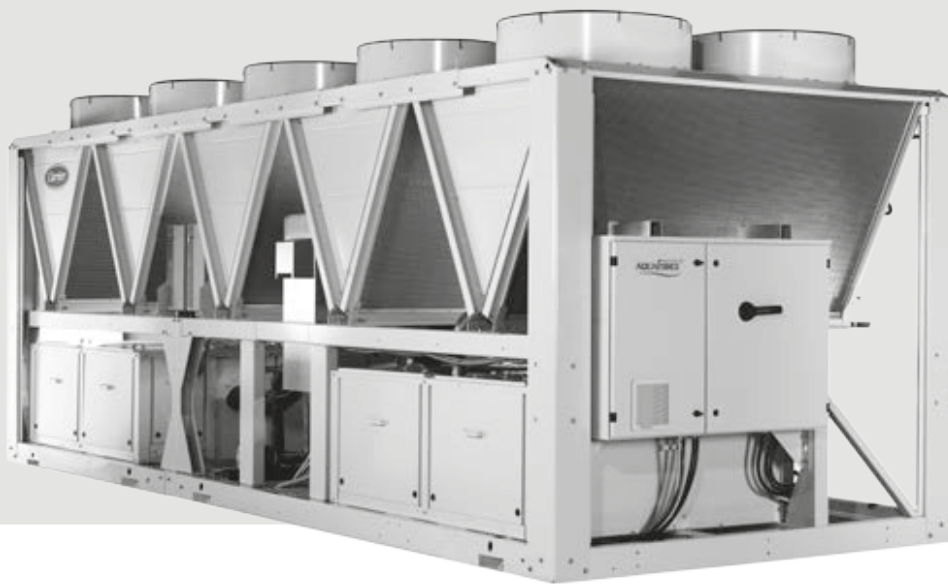

United Technologies



INSTALLATION, OPERATION AND
MAINTENANCE INSTRUCTIONS



Variable-Speed Air-Cooled Screw Chillers

30XAV 500 - 1150

Nominal cooling capacity : 500 - 1150 kW
50 Hz



Original document

CONTENTS

1 - INTRODUCTION	4
1.1 - Installation safety considerations	4
1.2 - Equipment and components under pressure	5
1.3 - Maintenance safety considerations	5
1.4 - Repair safety considerations	7
2 - PRELIMINARY CHECKS	8
2.1 - Check equipment received	8
2.2 - Moving and siting the unit	8
2.3 - Actual start-up	9
3 - DIMENSIONS, CLEARANCES	10
3.1 - 30XAV 500-600 without hydronic kit	10
3.2 - 30XAV 500-600 with hydronic kit	10
3.3 - 30XAV 700	11
3.4 - 30XAV 800	11
3.5 - 30XAV 950	12
3.6 - 30XAV 1050	12
3.7 - 30XAV 1150	13
3.8 - Multiple chiller installation	13
3.9 - Distance to the wall	13
4 - PHYSICAL AND ELECTRICAL DATA FOR 30XAV UNITS	14
4.1 - Physical data 30XAV	14
4.2 - Electrical data 30XAV	15
4.3 - Short-circuit stability current for 30XAV units	15
4.4 - Electrical data, optional hydronic module	16
4.5 - Compressor electrical data 30XAV	17
4.6 - Compressor usage per circuit(A, B)	17
5 - ELECTRICAL CONNECTION	18
5.1 - Power supply	18
5.2 - Voltage phase imbalance (%)	18
5.3 - Power connection/disconnect switch	18
5.4 - Recommended wire sections	18
5.5 - Power cable entry	18
5.6 - Field control wiring	19
5.7 - Electric and power reserve for the user	19
6 - APPLICATION DATA	20
6.1 - Operating range	20
6.2 - Minimum chilled water flow (units without hydronic module)	20
6.3 - Maximum chilled water flow (units without hydronic module)	20
6.4 - Variable flow evaporator	21
6.5 - System minimum water volume	21
6.6 - Evaporator water flow rate	21
6.7 - Evaporator pressure drop curve	21
7 - WATER CONNECTIONS	22
ATTENTION: BEFORE CARRYING OUT ANY WATER CONNECTIONS INSTALL THE WATER BOX DRAIN PLUGS (ONE PLUG PER WATER BOX IN THE LOWER SECTION - SUPPLIED IN THE CONTROL BOX). ..	22
7.1 - Operating precautions	22
7.2 - Victaulic water connections	23
7.3 - Flow detection	25
7.4 - Evaporator water box bolt tightening	25
7.5 - Freeze protection	25
7.6 - Protection against cavitation (with option 116)	25
7.7 - Operation of two units in master/slave mode (option 58)	26
8 - UNIT WITH HYDRONIC KIT	27
8.1 - Available static pressure for the system	27
8.2 - NPSH (Net Positive Suction Head) required ; Hydronic module option	28
8.3 - Flow rate and cooling capacity calculations	28

9 - MAJOR SYSTEM COMPONENTS AND OPERATION DATA.....	29
9.1 - Compressor	29
9.2 - Oil filter	29
9.3 - Refrigerant.....	29
9.4 - Lubricant	29
9.5 - Oil supply solenoid valve.....	29
9.6 - Suction and economiser screens	29
9.7 - Pressure vessels.....	29
9.8 - High-pressure safety switch	30
9.9 - Condensers.....	30
9.10 - Fans	30
9.11 - Electronic expansion valve (EXV)	31
9.12 - Moisture indicator.....	31
9.13 - Filter drier	31
9.14 - Sensors.....	31
9.15 - Service valve (option 92).....	32
9.16 - Variable frequency drive.....	32
10 - OPTIONS	33
11 - STANDARD MAINTENANCE.....	35
11.1 - Level 1 maintenance	35
11.2 - Level 2 maintenance	35
11.3 - Level 3 (or higher) maintenance	35
11.4 - Tightening torques for the main electrical connections.....	36
11.5 - Tightening torques for the main bolts and screws.....	36
11.6 - Condenser coil.....	36
11.7 - Evaporator maintenance	37
11.8 - Compressor maintenance.....	37
11.9 - Variable frequency drive maintenance	37
12 - CHECKLIST TO BE MADE BY THE INSTALLER BEFORE CALLING CARRIER SERVICE COMMISSIONING UNIT	38

The images shown on the cover page and in this document are for illustrative purposes only and are not contractual. The manufacturer reserves the right to change the design at any time without notice.

1 - INTRODUCTION

The 30XAV Aquaforce units are designed to cool water for the air conditioning of buildings and industrial processes.

Prior to the initial start-up of the 30XAV units, the people involved in the on-site installation, start-up, operation, and maintenance of this unit should be thoroughly familiar with these instructions and the specific project data for the installation site.

The 30XAV liquid chillers are designed to provide a very high level of safety during installation, start-up, operation and maintenance. They will provide safe and reliable service if used within their application range.

They are designed for an operating life of 15 years by assuming a 75% utilisation factor; that is approximately 100,000 operating hours.

Always ensure that all required safety measures are followed, including those in this document, such as: wearing protective clothing (gloves, ear defenders, safety glasses and shoes), using appropriate tools, employing qualified and skilled technicians (electricians, refrigeration engineers) and following local regulations.

To find out, if these products comply with European directives (machine safety, low voltage, electromagnetic compatibility, equipment under pressure etc.) check the declarations of conformity for these products.

1.1 - Installation safety considerations

Access to the unit must be restricted to authorised personnel, trained and qualified in monitoring and maintenance procedures. Access limitation is the responsibility of the customer.

After the unit has been received, when it is ready to be installed or reinstalled, and before it is started up, it must be inspected for damage. Check that the refrigerant circuit(s) is (are) intact, especially that no components or pipes have shifted (e.g. following a shock). If in doubt, carry out a leak tightness check and verify with the manufacturer that the circuit integrity has not been impaired. If damage is detected upon receipt, immediately file a claim with the shipping company.

Carrier strongly recommends employing a specialised company to unload the machine.

Do not remove the skid or the packaging until the unit is in its final position. These units can be moved with a fork lift truck, as long as the forks are positioned in the right place and direction on the unit.

The units can also be lifted with slings, using only the designated lifting points marked on the unit.

Use slings with the correct capacity, and always follow the lifting instructions on the certified drawings supplied with the unit.

Safety is only guaranteed, if these instructions are carefully followed. If this is not the case, there is a risk of failure and injuries to personnel.

DO NOT COVER ANY PROTECTION DEVICES. This applies to fuse plugs and relief valves (if used) in the refrigerant or heat transfer medium circuits. Check if the original protection plugs are still present at the valve outlets. These plugs are generally made of plastic and should not be used. If they are still present, please remove them. Install devices at the valve outlets or drain piping that prevent the penetration of foreign bodies (dust, building debris, etc.) and atmospheric agents (water can form rust or ice). These devices, as well as the drain piping, must not impair operation and not lead to a pressure drop that is higher than 10% of the control pressure.

Classification and control:

In accordance with the Pressure Equipment Directive and national usage monitoring regulations in the European Union, the protection devices when fitted to these machines are classified as follows:

	Safety accessory*	Damage limitation accessory** in case of an external fire
Refrigerant side		
High-pressure switch	X	
External relief valve***		X
Rupture disk		X
Fuse plug		X
Heat transfer fluid side		
External relief valve****	X	X

* Classified for protection in normal service situations.

** Classified for protection in abnormal service situations.

*** The instantaneous over-pressure limited to 10% of the operating pressure does not apply to this abnormal service situation. The control pressure can be higher than the service pressure. In this case either the design temperature or the high-pressure switch ensures that the service pressure is not exceeded in normal service situations.

**** The classification of these relief valve must be made by the personnel that completes the whole hydronic installation.

Do not remove valves / fusible plugs, even if the fire risk is under control for a particular installation. There is no guarantee that the accessories are re-installed if the installation is changed or for transport with a gas charge. When the unit is subjected to fire, safety devices prevent rupture due to over-pressure by releasing refrigerant. The fluid may then be decomposed into toxic residues when subjected to the flame:

- **Stay away from the unit.**
- **Set up warnings and recommendations for personnel in charge to stop the fire.**
- **Fire extinguishers appropriate to the system and the refrigerant type must be easily accessible.**

All factory -installed relief valves are lead-sealed to prevent any calibration change. The external relief valves must always be connected to vent pipes for units installed in a closed room. Refer to the installation regulations, for example those of European standard EN 378 and EN 13136.

These pipes must be installed in a way that ensures that people and property are not exposed to vented refrigerant. As the fluids can be diffused in the air, ensure that refrigerant is discharged away from building air intakes, relief valves must be checked periodically. See paragraph "Maintenance safety considerations"

Provide a drain in the vent pipe, close to each relief valve, to avoid an accumulation of condensate or rain water.

All precautions concerning handling of refrigerant must be observed in accordance with local regulations.

Ensure good ventilation, as accumulation of refrigerant in an enclosed space can displace oxygen and cause asphyxiation or explosions.

Inhalation of high concentrations of vapour is harmful and may cause heart irregularities, unconsciousness, or death. Vapour is heavier than air and reduces the amount of oxygen available for breathing. These products cause eye and skin irritation. Decomposition products are hazardous.

1.2 - Equipment and components under pressure

These products incorporate equipment or components under pressure, manufactured by Carrier or other manufacturers. Ensure that you are familiar with the appropriate national regulations / guidance for the ownership, use and maintenance of such systems. The characteristics of this equipment/these components are given on the nameplate or in the required documentation, supplied with the products.

These units comply with the European Pressure Equipment Directive.

The units are intended to be stored and operate in an environment where the ambient temperature must not be less than the lowest temperature indicated on the nameplate. Do not introduce high static and dynamic pressure compared with the existing operating pressures used during operation or for tests in the refrigerant circuit or in the heat exchange circuits.

NOTES: Monitoring during operation, re-qualification, retesting, exemption from retesting:

- *Follow local regulations on the monitoring of pressure-containing equipment.*
- *The user or the operator is usually requested to create and maintain a monitoring and maintenance register.*
- *In absence of regulation or in addition to the regulations, follow the guidance in EN 378.*
- *Follow the local professional recommendations, whenever they exist.*
- *Regularly monitor the surface of the components to detect cavernous corrosion. To do this, check an uninsulated part of the pressure vessel or at a joint in the insulation.*
- *Regularly check for possible presence of impurities (e.g. silicon grains) in the heat exchange fluids. These impurities can cause wear and/or pitting corrosion.*
- *Filter the heat exchange fluid.*
- *The reports of the periodical checks by the user or the operator must be included in the monitoring and maintenance register.*

REPAIR:

Any repair or modification of a pressurised vessel is prohibited.

Only the replacement of the vessel by an original part from the manufacturer is allowed. In this case, the replacement must be carried out by a qualified operator.

The replacement of the vessel must be entered in the monitoring and maintenance register.

RECYCLING:

The pressure equipment can be recycled in whole or in part. After use they may contain refrigerant vapours and oil residue. Some parts are painted.

1.3 - Maintenance safety considerations

Carrier recommends the following drafting for a logbook (the table below should not be considered as reference and does not involve Carrier responsibility):

Intervention		Name of the commissioning engineer	Applicable national regulations	Verification Organism
Date	Nature ⁽¹⁾			

(1) Maintenance, repairs, regular verifications (EN 378), leakage, etc.

Engineers working on the electrical or refrigeration components must be authorised, trained and fully qualified to do so.

All refrigerant circuit work must be carried out by a trained person, fully qualified to work on these units. He/she must have been trained and be familiar with the equipment and the installation. All welding operations must be carried out by qualified specialists.

Any manipulation (opening or closing) of a shut-off valve must be carried out by a qualified and authorised engineer, observing applicable standards (e.g. during draining operations). The unit must be switched off during maintenance.

NOTE: The unit must never be left shut down with the liquid line valve closed, as liquid refrigerant can be trapped between this valve and the expansion device and lead to the risk of a pressure increase. This valve is situated on the liquid line before the filter drier box.

During any handling, maintenance and service operations the engineers working on the unit must be equipped with safety gloves, glasses, shoes and protective clothing. Never work on any of the electrical components, until the general power supply to the unit has been cut using the disconnect switch(es) in the control box(es).

If any maintenance operations are carried out on the unit, lock the power supply circuit in the open position ahead of the machine.

CAUTION: The variable frequency drives used in the 30XAV units are equipped with capacitor batteries with a discharge time of twenty (20) minutes after disconnecting the power supply. After disconnecting the power supply of the control box, wait twenty minutes before opening the control box. Before any intervention, verify that there is no voltage present at any accessible conducting parts of the power circuit.

If the work is interrupted, always ensure that all circuits are still deenergised before resuming the work.

ATTENTION: Even if the unit has been switched off, the power circuit remains energised, unless the unit or circuit disconnect switch is open. Refer to the wiring diagram for further details. Attach appropriate safety labels.

When working in a fan area, specifically if the grilles have to be removed, isolate the power supply to the fans to prevent their operation

OPERATING CHECKS:

IMPORTANT INFORMATION REGARDING THE REFRIGERANT USED:

- This product contains fluorinated greenhouse gas covered by the Kyoto protocol.
- Fluid type: R134a
- Global Warming Potential (GWP): 1430

CAUTION:

1. Any intervention on the refrigerant circuit of this product should be performed in accordance with the applicable legislation. In the EU, the regulation is called F-Gas, N°517/2014.
2. Ensure that the refrigerant is never released to the atmosphere during installation, maintenance or equipment disposal.
3. The deliberate gas release into the atmosphere is not allowed.
4. If a refrigerant leak is detected, ensure that it is stopped and repaired as quickly as possible.
5. Only a qualified and certified personnel can perform installation operations, maintenance, refrigerant circuit leak test as well as the equipment disposal and the refrigerant recovering.
6. The gas recovery for recycling, regeneration or destruction is at customer charge.
7. Periodic leak tests have to be carried out by the customer or by third parties. The EU regulation set the periodicity here after

System WITHOUT leakage detection	No check	12 months	6 months	3 months	
System WITH leakage detection	No check	24 months	12 months	6 months	
Refrigerant charge/circuit (CO ₂ equivalent)	< 5 tons	5 ≤ charge < 50 tons	50 ≤ charge < 500 tons	Charge > 500 tons*	
Refrigerant charge/circuit (kg)	R134a (GWP 1430)	Charge < 3.5 kg	3.5 ≤ charge < 34.9 kg	34.9 ≤ charge < 349.7 kg	Charge > 349.7 kg
	R407C (GWP 1774)	Charge < 2.8 kg	2.8 ≤ charge < 28.2 kg	28.2 ≤ charge < 281.9 kg	Charge > 281.9 kg
	R410A (GWP 2088)	Charge < 2.4 kg	2.4 ≤ charge < 23.9 kg	23.9 ≤ charge < 239.5 kg	Charge > 239.5 kg
HFO's : R1234ze	No requirement				

* From 01/01/2017, units must be equipped with a leakage detection system

8. A logbook must be established for equipments subject to periodic leak tests. It should contain the quantity and the type of fluid present within the installation (added and recovered), the quantity of recycled fluid, regenerated or destroyed, the date and output of the leak test, the designation of the operator and its belonging company, etc.
9. Contact your local dealer or installer if you have any questions.

Information on operating inspections given in EN 378 standard can be used when similar criteria do not exist in the national regulation.

PROTECTION DEVICE CHECKS:

- If no national regulations exist, check the protection devices on site in accordance with standard EN 378: once a year for the high-pressure switches, every five years for external relief valves.

The company or organisation that conducts a pressure switch test must establish and implement a detailed procedure to fix:

- Safety measures
- Measuring equipment calibration
- Validating operation of protective devices
- Test protocols
- Recommissioning of the equipment.

Consult Carrier Service for this type of test. Carrier mentions here only the principle of a test without removing the pressure switch:

- Verify and and record the set-points of pressure switches and relief devices (valves and possible rupture discs)
- Be ready to switch-off the main disconnect switch of the power supply if the pressure switch does not trigger (avoid over-pressure or excess gas in case of valves on the high-pressure side with the recovery condensers)
- Connect a pressure gauge protected against pulsations (filled with oil with maximum pointer if mechanical), preferably calibrated (the values displayed on the user interface may be inaccurate in an instant reading because of the scanning delay applied in the control)
- Complete an HP Test as provided by the software (refer to the Control IOM for details).

CAUTION: If the test leads to replacing the pressure switch, it is necessary to recover the refrigerant charge, these pressure switches are not installed on automatic valves (Schraeder type).

At least once a year, visually inspect the protection devices (valves, pressure switches).

If the machine operates in a corrosive environment, inspect the protection devices more frequently.

Check regularly for leaks and repair immediately. Ensure regularly that the vibration levels remain acceptable and close to those at the initial unit start-up.

After an equipment failure, carry out a refrigerant analysis at a specialist laboratory. If required, change the refrigerant following a procedure such as that described in NF E29-795.

If the refrigerant circuit remains open after an intervention (such as a component replacement, etc.):

- Seal the openings if the duration is less than a day
- If more than 1 day, charge the circuit with oxygen free nitrogen (inertia principle).

The objective is to prevent penetration of atmospheric humidity and the resulting corrosion.

1.4 - Repair safety considerations

All installed parts must be maintained by the personnel in charge, in order to avoid deterioration and injury. Faults and leaks must be repaired immediately. The authorised technician must have the responsibility to repair the fault immediately. After each repair of the unit, check the operation of the protection devices and record their correct operation in the maintenance log.

Comply with the regulations and recommendations in unit and HVAC installation safety standards, such as: EN 378, ISO 5149, etc.

If a leak occurs or if the refrigerant becomes contaminated (e.g. by a short circuit in a motor) remove the complete charge using a recovery unit and store the refrigerant in mobile containers. The compressors do not allow to transfer the refrigerant charge and can be broken if they are used to pump down. The refrigerant charge should not be transferred to the high-pressure side.

Repair the leak, detect and recharge the circuit with the total R-134A charge, as indicated on the unit name plate. Certain parts of the circuit can be isolated. Only charge liquid refrigerant R-134A at the liquid line.

Always ensure you are using the correct refrigerant type before recharging the unit. Charging any refrigerant other than the original type (R-134A) will impair machine operation and can even lead to a destruction of the compressors. The compressors operating with this refrigerant type are lubricated with a synthetic polyolester oil.

RISK OF EXPLOSION:



Never use air or a gas containing oxygen during leak tests to purge lines or to pressurise a machine. Pressurised air mixtures or gases containing oxygen can be the cause of an explosion.

Only use dry nitrogen for leak tests, possibly with an appropriate tracer gas.

If the recommendations above are not observed, this can have serious or even fatal consequences and damage the installation.

Never exceed the specified maximum operating pressures. Verify the allowable maximum high- and low- side test pressures by checking the instructions in this manual and the pressures given on the unit name plate.

Do not unweld or flamecut the refrigerant lines or any refrigerant circuit component until all refrigerant (liquid and vapour) as well as the oil have been removed from chiller. Traces of vapour should be displaced with dry nitrogen. Refrigerant in contact with an open flame produces toxic gases.

The necessary protection equipment must be available, and appropriate fire extinguishers for the system and the refrigerant type used must be within easy reach.

Do not siphon refrigerant.

Avoid spilling liquid refrigerant on skin or splashing it into the eyes. Use safety goggles and safety gloves. Wash any spills from the skin with soap and water. If liquid refrigerant enters the eyes, immediately and abundantly flush the eyes with water and consult a doctor.

The accidental releases of the refrigerant, due to small leaks or significant discharges following the rupture of a pipe or an unexpected release from a relief valve, can cause frostbites and burns to personnel exposed. Do not ignore such injuries. Installers, owners and especially service engineers for these units must:

- *Seek medical attention before treating such injuries.*
- *Have access to a first-aid kit, especially for treating eye injuries.*

We recommend to apply standard EN 378-3 Annex 3.

Never apply an open flame or live steam to a refrigerant container. Dangerous overpressure can result. If it is necessary to heat refrigerant, use only warm water.

During refrigerant removal and storage operations follow applicable regulations. These regulations, permitting conditioning and recovery of halogenated hydrocarbons under optimum quality conditions for the products and optimum safety conditions for people, property and the environment are described in standard NF E29-795.

Any refrigerant transfer and recovery operations must be carried out using a transfer unit. A 3/8" SAE connector on the manual liquid line valve is supplied with all units for connection to the transfer station. The units must never be modified to add refrigerant and oil charging, removal and purging devices. All these devices are provided with the units. Please refer to the certified dimensional drawings for the units.

Do not re-use disposable (non-returnable) cylinders or attempt to refill them. It is dangerous and illegal. When cylinders are empty, evacuate the remaining gas pressure, and move the cylinders to a place designated for their recovery. Do not incinerate.

ATTENTION: Only use refrigerant R134a, in accordance with 700 AHRI (Air conditioning, Heating and Refrigeration Institute). The use of any other refrigerant may expose users and operators to unexpected risks.

Do not attempt to remove refrigerant circuit components or fittings, while the machine is under pressure or while it is running. Be sure pressure is at 0 kPa and that the unit has been shut-down and de-energised before removing components or opening a circuit.

When the refrigerant circuit is opened for repair, it is mandatory to plug all openings of the circuit if the repair exceeds 30 minutes; this is to avoid moisture absorbed in the circuit, especially in the oil. If the scheduled intervention is longer, the circuit must be charged with nitrogen.

Do not attempt to repair or recondition any safety devices when corrosion or build-up of foreign material (rust, dirt, scale, etc.) is found within the valve body or mechanism. If necessary, replace the device.

Do not install relief valves in series or backwards.

ATTENTION: No part of the unit must be used as a walkway, rack or support. Periodically check and repair or if necessary replace any component or piping that shows signs of damage.

The refrigerant lines can break under the weight and release refrigerant, causing personal injury.

Do not climb on a machine. Use a platform, or staging to work at higher levels.

Use mechanical lifting equipment (crane, hoist, winch, etc.) to lift or move heavy components. For lighter components, use lifting equipment when there is a risk of slipping or losing your balance.

Use only original replacement parts for any repair or component replacement. Consult the list of replacement parts that corresponds to the specification of the original equipment.

Do not drain water circuits containing industrial brines, without informing the technical service department at the installation site or a competent body first.

Close the entering and leaving water shutoff valves and drain the unit water circuit, before working on the components installed on the circuit (screen filter, pump, water flow switch, etc.).

Do not loosen the water box bolts until the water boxes have been completely drained.

Periodically inspect all valves, fittings and pipes of the refrigerant and hydronic circuits to ensure that they do not show any corrosion or any signs of leaks.

It is recommended to wear ear defenders, when working near the unit and the unit is in operation.

2 - PRELIMINARY CHECKS

2.1 - Check equipment received

- Check that the unit has not been damaged during transport and that no parts are missing. If the unit has been damaged or the shipment is incomplete, send a claim to the shipping company.
- Compare the name plate data with the order. The name plate is attached in two places to the unit:
 - On one of the unit sides on the outside
 - On the control box door on the inside.
- The unit name plate must include the following information:
 - Version number
 - Model number
 - CE marking
 - Serial number
 - Year of manufacture and test date
 - Refrigerant used and refrigerant class
 - Refrigerant charge per circuit
 - Containment fluid to be used
 - PS: Min./max. allowable pressure (high and low pressure side)
 - TS: Min./max. allowable temperature (high and low pressure side)
 - Pressure switch cut-out pressure
 - Unit leak test pressure

- Voltage, frequency, number of phases
- Maximum current drawn
- Maximum power input
- Unit net weight
- Confirm that all accessories ordered for on-site installation have been delivered and are complete and undamaged.

The unit must be checked periodically during its whole operating life to ensure that no shocks (handling accessories, tools etc.) have damaged it. If necessary, damaged parts must be repaired or replaced. See also chapter 8 - "Standard maintenance".

2.2 - Moving and siting the unit

2.2.1 - Moving

See chapter 1.1 "Installation safety considerations".

2.2.2 - Placing the unit

The machine must be installed in a place that is not accessible to the public or protected against access by non-authorised persons.

In case of extra-high units the machine environment must permit easy access for maintenance operations.

Always refer to the chapter 3 "Dimensions, clearances" to confirm that there is adequate space for all connections and service operations. For the centre of gravity coordinates, the position of the unit mounting holes, and the weight distribution points, refer to the certified dimensional drawing supplied with the unit.

The support points under the chassis must have at least the size of the chassis opening at the lifting point (minimum 220 x 180 mm) in order to prevent a deformation of the chassis.

Typical applications of these units are in refrigeration systems, and they do not require earthquake resistance. Earthquake resistance has not been verified.

CAUTION: Only use slings at the designated lifting points which are marked on the unit.

Before siting the unit check that:

- The permitted loading at the site is adequate or that appropriate strengthening measures have been taken.
- The unit is installed level on an even surface (maximum tolerance is 5 mm in both axes).
- There is adequate space above the unit for air flow and to ensure access to the components.
- If the support structure is sensitive to vibration and/or noise transmission, it is advisable to insert anti-vibration mounts (elastomeric mounts or springs) between the unit and the structure. Selection of these devices is based on the system characteristics and the comfort level required and should be made by technical specialists.
- The number of support points is adequate and that they are in the right places.
- The location is not subject to flooding.
- For outdoor installations, where heavy snowfall is likely and long periods of sub-zero temperatures are normal, provision has to be made to prevent snow accumulating by raising the unit above the height of drifts normally

experienced.

- Baffles may be necessary to deflect strong winds. They must not restrict air flow into the unit.

CAUTION: Before lifting the unit, check that all casing panels are securely fixed in place. Lift and set down the unit with great care. Tilting and jarring can damage the unit and impair unit operation.

If 30XAV units are hoisted with rigging, it is advisable to protect coils against crushing while a unit is being moved. Use struts or spreader bar to spread the slings above the unit. Do not tilt a unit more than 15°.

WARNING: Never push or lever on any of the enclosure panels of the unit. Only the base of the unit frame is designed to withstand such stresses.

No force or effort must be applied to pressurised parts, especially via pipes connected to the evaporator.

2.2.3 - Checks before system start-up

Before the start-up of the refrigeration system, the complete installation, including the refrigeration system must be verified against the installation drawings, dimensional drawings, system piping and instrumentation diagrams and the wiring diagrams.

Heat exchange fluid temperatures above the maximum recommended can lead to an increase in the refrigerant pressure and can cause a loss of refrigerant due to the relief valve discharge.

For these checks national regulations must be followed. If the national regulation does not specify any details, refer to standard EN 378 as follows:

External visual installation checks:

- Compare the complete installation with the refrigeration system and power circuit diagrams.
- Check that all components comply with the design specifications.
- Check that all protection documents and equipment provided by the manufacturer (dimensional drawings, P&ID, declarations, etc.) to comply with the regulations are present.
- Verify that the environmental safety and protection devices and arrangements provided by the manufacturer to comply with the regulations are in place.
- Verify that all documents for pressure containers, certificates, name plates, files, instruction manuals provided by the manufacturer to comply with the regulations are present.
- Verify the free passage of access and safety routes.
- Check that ventilation in the plant room is adequate.
- Check that refrigerant detectors are present.
- Verify the instructions and directives to prevent the venting removal of refrigerant gases that are harmful to the environment.
- Verify the installation of connections.
- Verify the supports and fixing elements (materials, routing and connection).
- Verify the quality of welds and other joints.
- Check the protection against mechanical damage.
- Check the protection against heat.
- Check the protection of moving parts.
- Verify the accessibility for maintenance or repair and

to check the piping.

- Verify the status of the valves.
- Verify the quality of the thermal insulation and of the vapour barriers.

2.3 - Actual start-up

Never be tempted to start the chiller without reading fully, and understanding, the operating instructions and without having carried out the following pre-start checks:

- Check the chilled water circulation pumps, the air handling equipment and any other device connected to the evaporator.
- Refer to the manufacturer instructions.
- Refer to the electrical diagram delivered with the unit.
- Ensure that there is no refrigerant leak.
- Check the tightening of fixing clamps of all pipes.
- Check the power supply at the main connection point and the order of phases.
- Check the correct operation of the heaters and check that they are correctly energised.

WARNING: Commissioning and start-up of the chiller must be supervised by a qualified refrigeration engineer.

- **Start-up and operating tests must be carried out with a thermal load applied and water circulation in the evaporator.**
- **All set-point adjustments and control tests must be carried out before the unit is started up.**
- **Refer to the Service guide 30XAV.**

Proceed with the unit commissioning.

Ensure that all safety devices are operational, especially that the high pressure switches are functioning and that any alarms have been acknowledged and corrected.

NOTE: If the Carrier instructions (power and water connections and installation) are not observed, the Carrier warranty becomes invalid.

3 - DIMENSIONS, CLEARANCES

3.1 - 30XAV 500-600 without hydronic kit

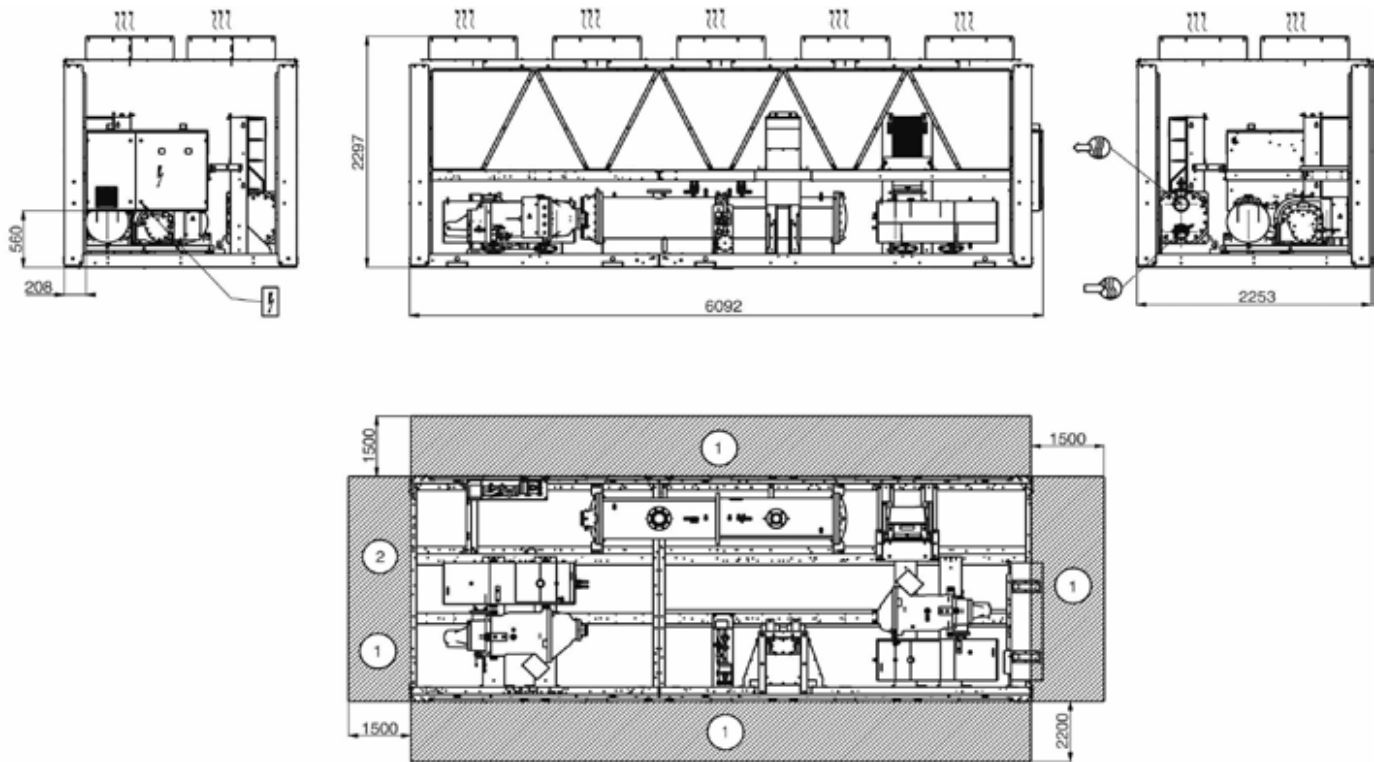

3.2 - 30XAV 500-600 with hydronic kit

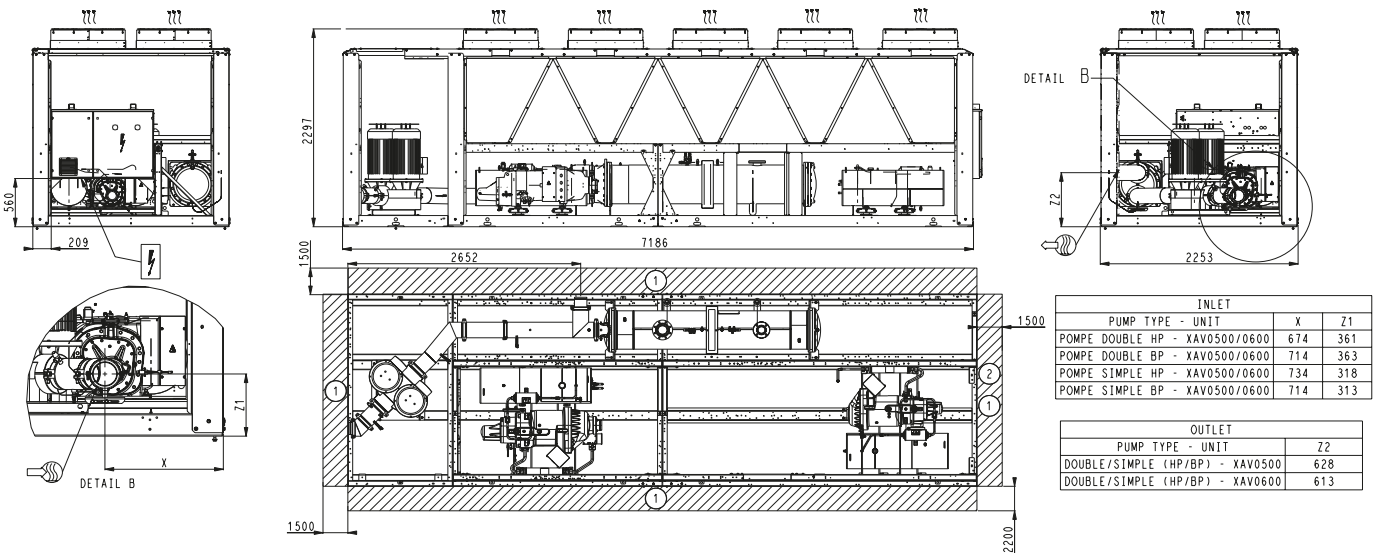

Legend:

All dimensions are given in mm.

- ① Required clearances for maintenance (see note)
- ② Recommended space for evaporator tube removal
- Water inlet for standard unit
For options 5, 6, 100A, 100C, 107 refer to the certified drawing.
- Water outlet for standard unit
For options 5, 6, 100A, 100C, 107 refer to the certified drawing.
- Air outlet – do not obstruct
- Power supply and control connection
- © Control circuit connection for option 158

NOTES:

- Drawings are not contractually binding.
- Before designing an installation, consult the certified dimensional drawings, available on request.
- For the positioning of the fixing points, weight distribution and centre of gravity coordinates please refer to the dimensional drawings.
- If any unit(s) are close to walls, please refer to chapters 3.8 - 3.9 - “Distance to the wall” of this document to determine the space required.

3.3 - 30XAV 700

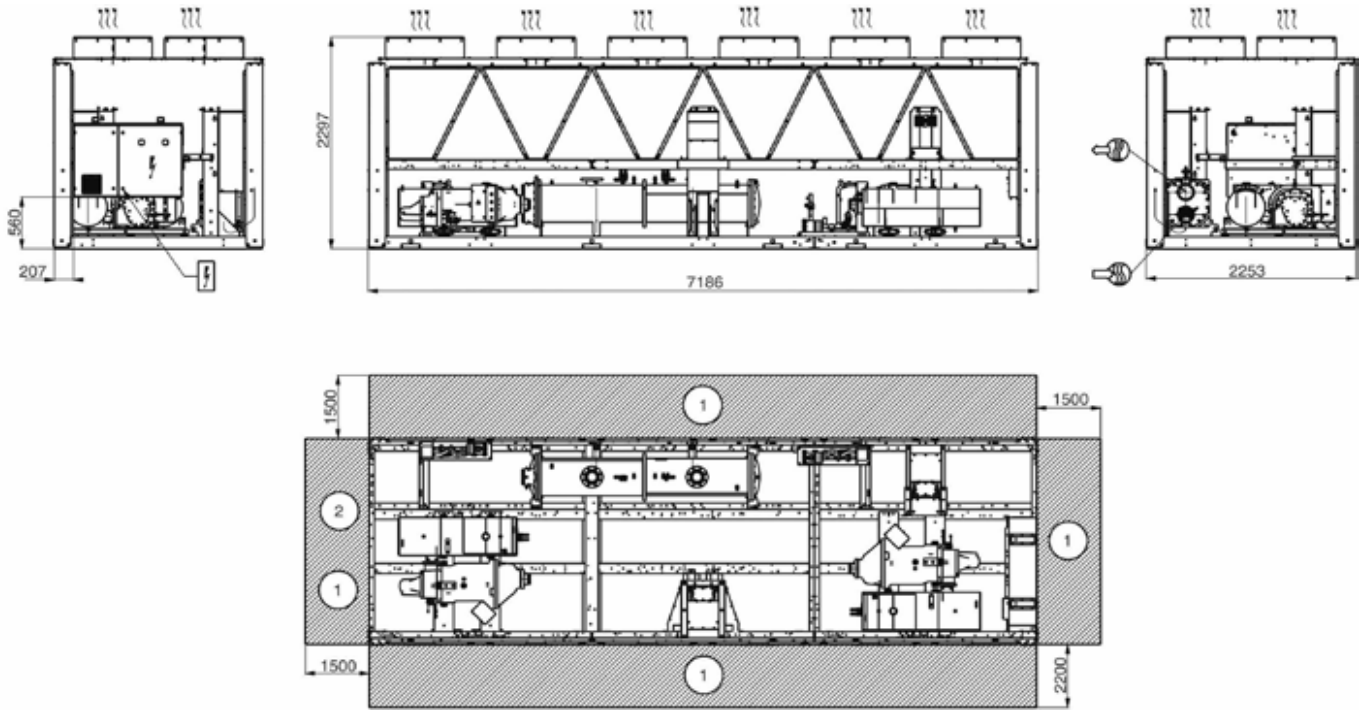

3.4 - 30XAV 800

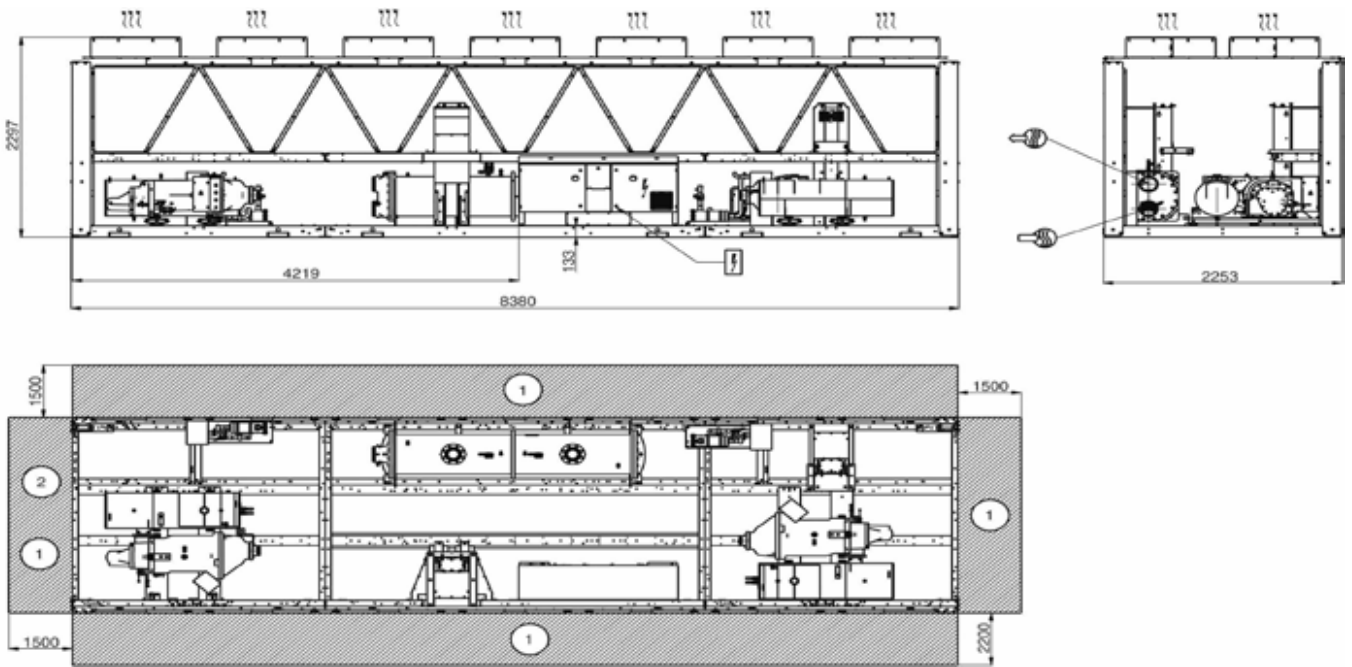

Legend:

All dimensions are given in mm.

- ① Required clearances for maintenance (see note)
- ② Recommended space for evaporator tube removal
- Water inlet for standard unit
For options 5, 6, 100A, 100C, 107 refer to the certified drawing.
- Water outlet for standard unit
For options 5, 6, 100A, 100C, 107 refer to the certified drawing.
- Air outlet – do not obstruct
- Power supply and control connection
- © Control circuit connection for option 158

NOTES:

- *Drawings are not contractually binding.*
- *Before designing an installation, consult the certified dimensional drawings, available on request.*
- *For the positioning of the fixing points, weight distribution and centre of gravity coordinates please refer to the dimensional drawings.*
- *If any unit(s) are close to walls, please refer to chapters 3.8 - 3.9 - “Distance to the wall” of this document to determine the space required.*

3.5 - 30XAV 950

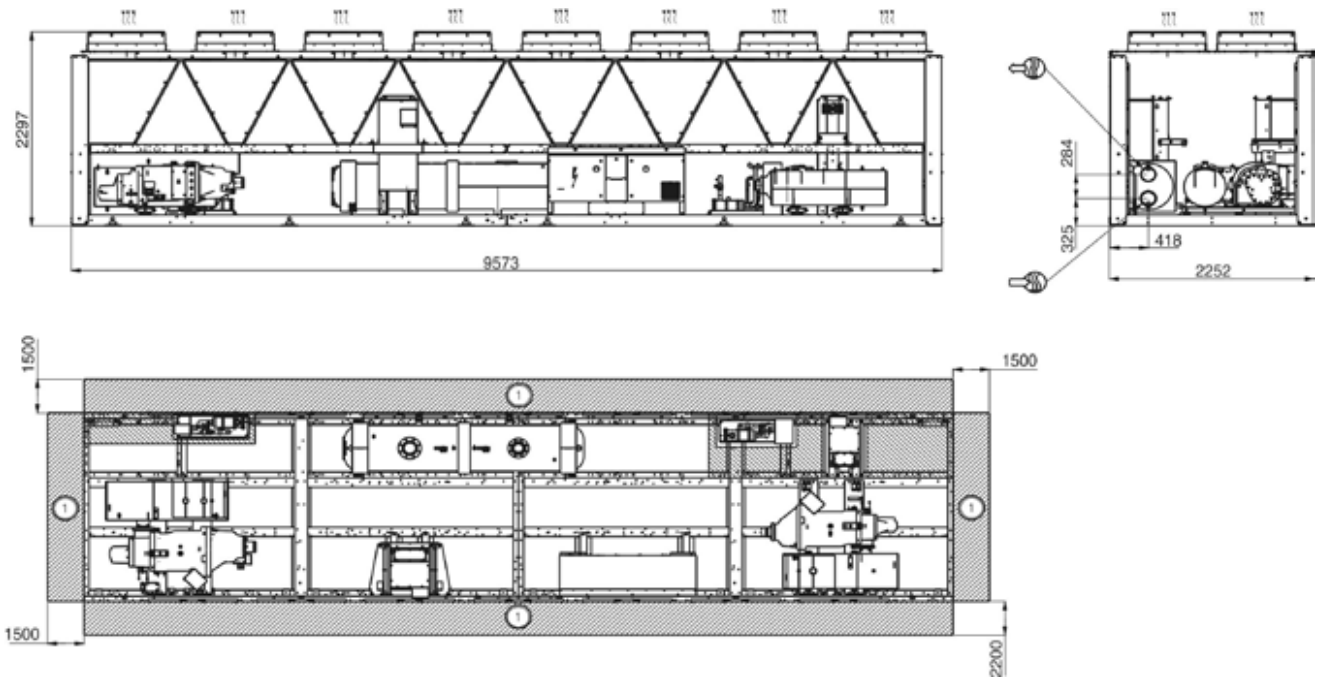

3.6 - 30XAV 1050

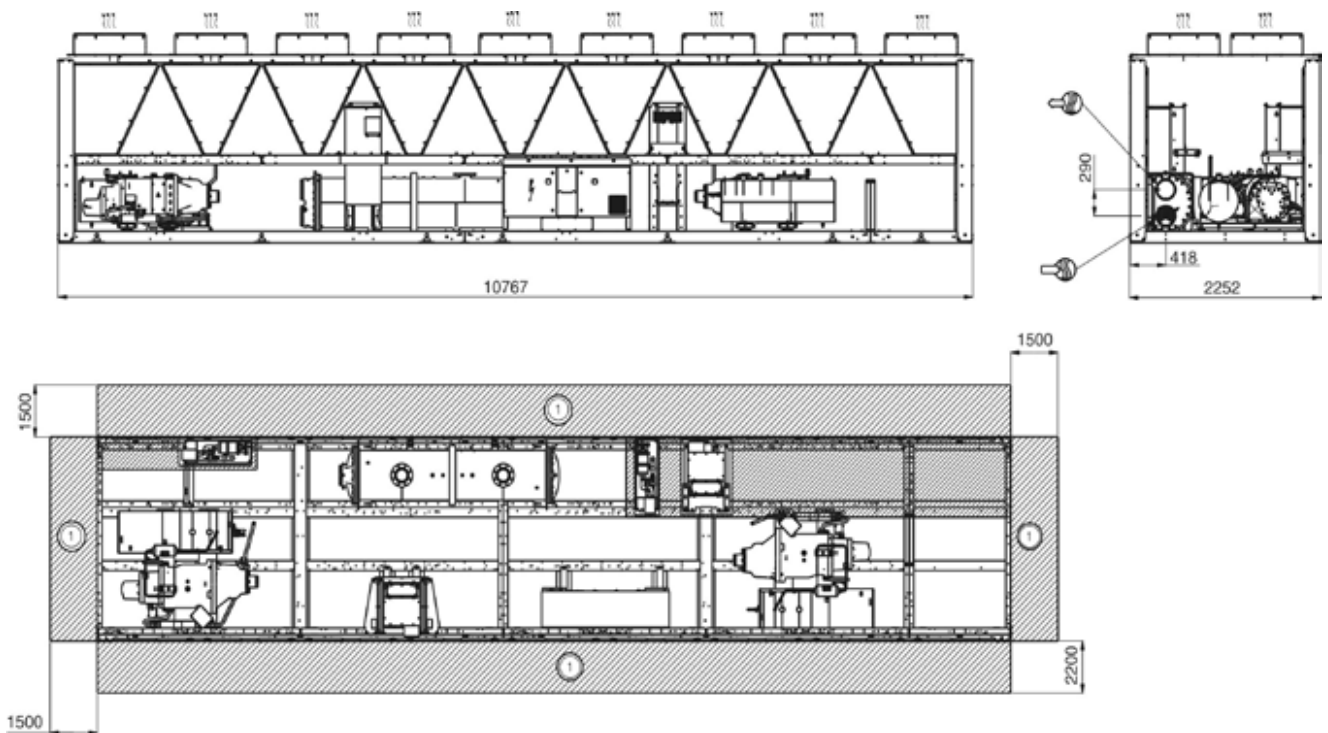

Legend:

All dimensions are given in mm.

- ① Required clearances for maintenance (see note)
- ② Recommended space for evaporator tube removal
- Water inlet for standard unit
For options 5, 6, 100A, 100C, 107 refer to the certified drawing.
- Water outlet for standard unit
For options 5, 6, 100A, 100C, 107 refer to the certified drawing.
- Air outlet – do not obstruct
- Power supply and control connection
- Control circuit connection for option 158

NOTES:

- **Drawings are not contractually binding.**
- **Before designing an installation, consult the certified dimensional drawings, available on request.**
- **For the positioning of the fixing points, weight distribution and centre of gravity coordinates please refer to the dimensional drawings.**
- **If any unit(s) are close to walls, please refer to chapters 3.8 - 3.9 - “Distance to the wall” of this document to determine the space required.**

3.7 - 30XAV 1150

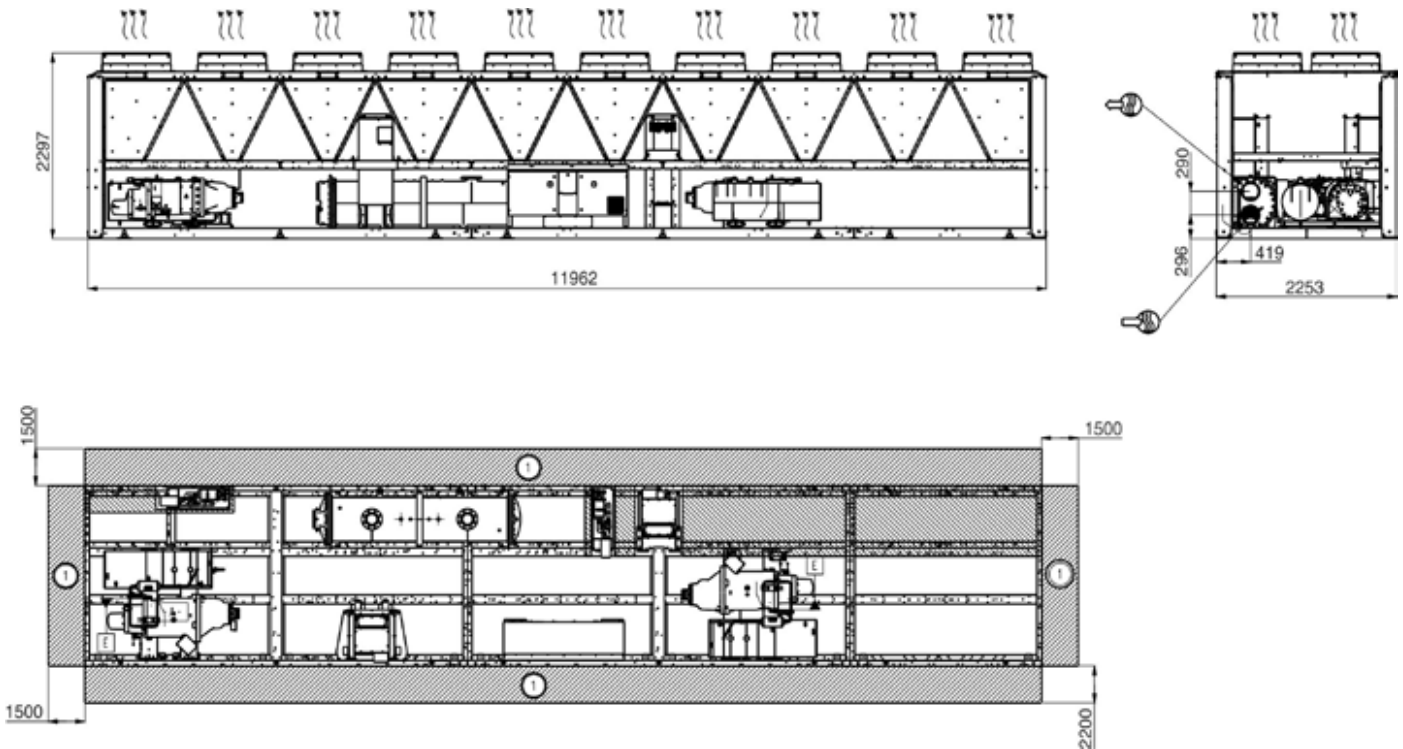

Legend:

All dimensions are given in mm.

- ① Required clearances for maintenance (see note)
- ② Recommended space for evaporator tube removal
- Water inlet for standard unit
For options 5, 6, 100A, 100C, 107 refer to the certified drawing.
- Water outlet for standard unit
For options 5, 6, 100A, 100C, 107 refer to the certified drawing.
- Air outlet – do not obstruct
- Power supply and control connection
- ⓐ Control circuit connection for option 158

NOTES:

- *Drawings are not contractually binding.*
- *Before designing an installation, consult the certified dimensional drawings, available on request.*
- *For the positioning of the fixing points, weight distribution and centre of gravity coordinates please refer to the dimensional drawings.*
- *If any unit(s) are close to walls, please refer to chapters 3.8 - 3.9 - “Distance to the wall” of this document to determine the space required.*

3.8 - Multiple chiller installation

It is recommended to install multiple chillers in a single row, arranged as shown in the example below, to avoid recycling of warm air from one unit to another.



If the situation at the site does not permit this arrangement, contact your Carrier distributor to evaluate the various possible arrangements. In certain situations an accessory (supplied loose at the time of purchase) can be added.

3.9 - Distance to the wall

To ensure correct operation for most cases:

If $h < H$ (2.3 m), minimum $S = 3$ m

If $h > H$ or $S < 3$ m, contact your Carrier distributor to evaluate the various possible arrangements. In certain situations an accessory (supplied loose at the time of purchase) can be added.

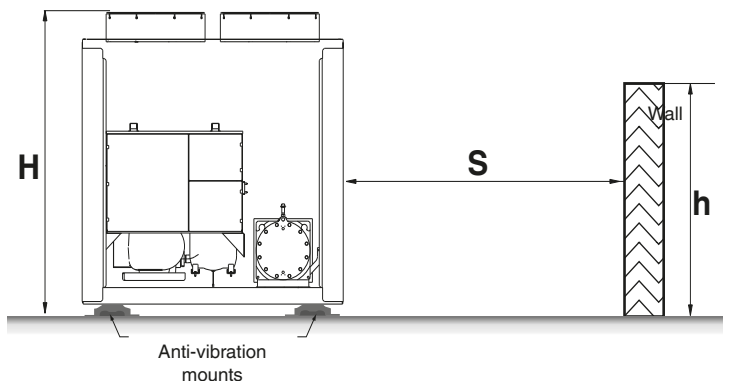

4 - PHYSICAL AND ELECTRICAL DATA FOR 30XAV UNITS

4.1 - Physical data 30XAV

30XAV		500	600	700	800	950	1050	1150
Sound levels								
Standard unit								
Sound power level***	dB(A)	102	103	103	103	105	106	106
Sound pressure level at 10 m****	dB(A)	70	70	70	70	72	73	73
Standard unit + option 279*								
Sound power level***	dB(A)	99	100	100	100	102	103	103
Sound pressure level at 10 m****	dB(A)	67	68	68	67	69	70	70
Standard unit + option 257*								
Sound power level***	dB(A)	96	97	97	97	99	100	100
Sound pressure level at 10 m****	dB(A)	63	65	64	64	66	67	67
Dimensions - Standard unit								
Length	mm	6092	6092	7186	8380	9573	10767	11962
Width	mm	2253	2253	2253	2253	2253	2253	2253
Height	mm	2297	2297	2297	2297	2297	2297	2297
Operating Weight**								
Standard unit	kg	4831	5219	5767	6420	6806	7687	8076
Compressors								
Circuit A		1	1	1	1	1	1	1
Circuit B		1	1	1	1	1	1	1
Refrigerant**								
		R134A						
Circuit A	kg	50	52	56	64	79	80	84
	teqCO ₂	71.5	74.4	80.1	91.5	113.0	114.4	120.1
Circuit B	kg	43	54	58	67	71	82	87
	teqCO ₂	61.5	77.2	82.9	95.8	101.5	117.3	124.4
		Touch Pilot control						
Minimum capacity*****	%	10	10	10	10	10	10	10
Condensers								
All aluminium Micro Channel Heat Exchanger (MCHE)								
Fans - Standard unit								
Axial FLYING-BIRD IV fans with rotating shroud								
Quantity		9	10	12	14	16	18	20
Maximum total air flow	l/s	40608	45120	54144	63168	72192	81216	90240
Maximum rotational speed	rps	15.7	15.7	15.7	15.7	15.7	15.7	15.7
Evaporator								
Flooded multi-pipe type								
Water volume	l	75	90	90	110	120	134	146
Max water-side operating pressure		1000	1000	1000	1000	1000	1000	1000
Hydronic module								
Victaulic type								
Diameter	inch	5	6	6	6	6	8	8
Outside tube diameter	mm	141.3	168.3	168.3	168.3	168.3	219.1	219.1
Chassis paint colour								
Colour code: RAL7035								

* Options: 257 = low sound level, 279 = compressor enclosure

** Values are guidelines only. Refer to the unit nameplate.

*** In dB ref=10⁻¹² W, (A) weighting. Declared dualnumber noise emission values in accordance with ISO 4871 (with an associated uncertainty of +/-3dB(A)). Measured in accordance with ISO 9614-1 and certified by Eurovent.

**** In dB ref 20 µPa, (A) weighting. Declared dualnumber noise emission values in accordance with ISO 4871 (with an associated uncertainty of +/-3dB(A)). For information, calculated from the sound power level Lw(A).

***** For standard conditions. Depending on operating conditions, unit might have a different minimum capacity or cycle.

4.2 - Electrical data 30XAV

30XAV		500	600	700	800	950	1050	1150
Power circuit								
Voltage range	V-ph-Hz	400-3-50±10%						
Control circuit supply								
24 V via internal transformer								
Start-up Current*								
Not Applicable (less than the operating current)								
Power factor**								
	-							
Maximum***		0.91-0.93						
Cosine phi		> 0.98						
Total harmonic distortion***	%	35-45						
Maximum unit power input****								
Circuit 1†	kW	223	255	293	186	231	231	255
Circuit 2†	kW	-	-	-	186	186	231	255
Option 81	kW	-	-	-	373	417	461	510
Nominal unit current draw ††								
Circuit 1†	A	260	306	346	218	264	264	293
Circuit 2†	A	-	-	-	218	218	264	293
Option 81	A	-	-	-	436	482	528	586
Maximum unit current draw (Un)****								
Circuit 1	A	352	400	458	290	362	362	402
Circuit 2	A	-	-	-	290	290	362	402
Option 81	A	-	-	-	580	652	724	804
Maximum unit current draw (Un-10%)***								
Circuit 1†	A	373	424	484	304	387	387	430
Circuit 2†	A	-	-	-	304	304	387	430
Option 81	A	-	-	-	608	691	774	860

* Instantaneous start-up current

** May vary depending on the intensity ratio of short circuit / maximum intensity transformer installation

*** Values obtained at operation with maximum unit power input.

**** Values obtained at operation with maximum unit power input. Values given on the unit nameplate.

† When the machines are equipped with two power supplies, circuit 1 is intended to supply the refrigerant circuit A and circuit 2 supplies the refrigerant circuit B

†† Values obtained at standard Eurovent operating condition: Air 35 °C, water 12/7 °C.

4.3 - Short-circuit stability current for 30XAV units

30XAV		500	600	700	800	950	1050	1150
Short-circuit stability current (TN system)*								
Standard unit								
Short-time (1s) assigned current I_{cn} / Peak current I_{pk}								
Circuit 1	kA	-	8/37	10/40	7.5/30	13/37	13/37	14/40
Circuit 2	kA	-	-	-	7.5/30	7,5/30	13/37	14/40
Assigned conditional short-circuit current I_{cc}/I_{cf}								
Circuit 1	kA	50	-	-	-	-	-	-
With fuses upstream - maximum fuse values assigned (gL/gG)								
Circuit 1	A	-	630	630	400	500	500	630
Circuit 2	A	-	-	-	400	400	500	630
With fuses upstream - Assigned conditional short circuit current I_{cc}/I_{cf}								
Circuit 1	kA	-	50	50	50	50	50	50
Circuit 2	kA	-	-	-	50	50	50	50
Units with option 81 or 70D								
Assigned conditionnal short circuit current I_{cc}/I_{cf}								
Circuit 1	kA*	-	50	50	50	50	50	50
Circuit 2	kA*	-	-	-	50	50	50	50
Option 81	kA*	-	-	-	50	50	50	50

* TN system (earthing system type)

4.4 - Electrical data, optional hydronic module

The pumps that are factory-installed in these units comply with the European Ecodesign directive ErP. The additional electrical data required* is as follows:

For low pressure pump motors (options 116F & 116G)

N°**	Description***	Units	30XAV	
			500	600
1	Nominal efficiency at full load and nominal voltage	%	89,4	89,4
1	Nominal efficiency at 75% rated load and nominal voltage	%	88,9	88,9
1	Nominal efficiency at 50% rated load and nominal voltage	%	86,7	86,7
2	Efficiency level	-	IE3	IE3
3	Year of manufacture	-	This information varies depending on the manufacturer and model at the time of incorporation. Please refer to the motor name plates.	
4	Manufacturer's name and trademark, commercial registration number and place of manufacturerw	-	Same as above	
5	Product's model number	-	Same as above	
6	Number of motor poles	-	2	2
7-1	Rated shaft power output at full load and nominal voltage (400Vw)	kW	5,5	5,5
7-2	Maximum power input † (400 V)	kW	6,15	6,15
8	Rated input frequency	Hz	50	50
9-1	Rated voltage	V	3 x 400	3 x 400
9-2	Maximum current drawn †† (400 V)	A	9,7	9,7
10	Rated speed	r/s - rpm	49 -2930	49 -2930
11	Product disassembly, recycling or disposal at end of life	-	Disassembly using standard tools. Disposal and recycling using an appropriate company.	
12	Operating conditions for which the motor is specifically designed			
	I. Altitudes above sea level	m	< 1000****	
	II. Ambient air temperature	°C	< 40* (up to 50°C with reduced water flow)	
	III. Maximum air temperature	°C	Please refer to the operating conditions given in this manual or in the specific conditions in the Carrier selection programs.	
	IV. Potentially explosive atmosphere	-	Non ATEX environment	

For of high pressure pump motors (options 116B & 116C)

N°*	Description***	Units	30XA	
			500	600
1	Nominal efficiency at full load and nominal voltage	%	91,3	91,3
1	Nominal efficiency at 75% rated load and nominal voltage	%	91,4	91,4
1	Nominal efficiency at 50% rated load and nominal voltage	%	90,3	90,3
2	Efficiency level	-	IE3	IE3
3	Year of manufacture	-	This information varies depending on the manufacturer and model at the time of incorporation. Please refer to the motor name plates.	
4	Manufacturer's name and trademark, commercial registration number and place of manufacturer	-	Same as above	
5	Product's model number	-	Same as above	
6	Number of motor poles	-	2	2
7-1	Rated shaft power output at full load and nominal voltage (400V)	kW	11	11
7-2	Maximum power input † (400 V)	kW	12	12
8	Rated input frequency	Hz	50	50
9-1	Rated voltage	V	3 x 400	3 x 400
9-2	Maximum current drawn †† (400 V)	A	18.7	18.7
10	Rated speed	r/s - rpm	49 - 2945	49 - 2945
11	Product disassembly, recycling or disposal at end of life	-	Disassembly using standard tools. Disposal and recycling using an appropriate company.	
12	Operating conditions for which the motor is specifically designed			
	I. Altitudes above sea level	m	< 1000****	
	II. Ambient air temperature	°C	< 40* (up to 50°C with reduced water flow)	
	III. Maximum air temperature	°C	Please refer to the operating conditions given in this manual or in the specific conditions in the Carrier selection programs.	
	IV. Potentially explosive atmosphere	-	Non ATEX environment	

* Required by regulation 640/2009 with regard to the application of directive 2009/125/EC on the eco-design requirements for electrical motors

** Item number imposed by regulation 640/2009, annex I2b

*** Description given by regulation 640/2009, annex I2b

**** Above 1000m, a degradation of 3% for each 500m should be taken into consideration

† To obtain the maximum power input for a unit with hydronic module, add the maximum unit power input from the electrical data table to the pump power input

†† To obtain the maximum unit operating current draw for a unit with hydronic module, add the maximum unit current draw from electrical data table to the pump current draw

4.5 - Compressor electrical data 30XAV

Compressor	Voltage / frequency assigned	I Nom*	I Max (Un)**	MHA	Cosine Phi max **
06TSA186	380V-60Hz	108	142	151	0.91
06TTA266	380V-60Hz	157	199	211	0.92
06TTA301	380V-60Hz	176	223	237	0.92
06TTA356	380V-60Hz	224	270	287	0.92
06TUA483	380V-60Hz	260	360	374	0.92
06TUA554	380V-60Hz	285	395	424	0.92

* Average value for the range (unit at Eurovent conditions)

** Value at maximum capacity and nominal voltage (380 V)

MHA Maximum compressor operating current, limited by the unit (current given for maximum capacity at 360 V)

4.6 - Compressor usage per circuit(A, B)

Compressor	30XAV						
	500	600	700	800	950	1050	1150
06TSA186	B	—	—	—	—	—	—
06TTA266	A	AB	—	—	—	—	—
06TTA301	—	—	AB	—	—	—	—
06TTA356	—	—	—	AB	B	—	—
06TUA483	—	—	—	—	A	AB	—
06TUA554	—	—	—	—	—	—	AB

Electrical data notes and operating conditions for 30XAV units

- 30XAV 0500 to 0700 units have a single power connection point located immediately upstream of the main switch(es). Standard units 0800 to 1150, have two power connection points located in the immediate upstream of the main switches.
 - With the exception of size 0500 and the units that are equipped with 81 and 70D options, anti short-circuits device is not provided as standard. It must be installed at the facility in accordance with the instructions given in this document.
 - The compressor and condenser fan motors are controlled and protected by variable frequency drives installed on the machine frame.
 - **The electrical control box contains:**
 - A main disconnect switch for the entire machine for 0600 and 0700 sizes. A disconnect switch for each refrigeration circuit for 0500 and 0800 to 1150 sizes.
 - All or part of the protection equipment against short-circuits for the circuits inside the machine*
 - Switch gear and protection for heaters and hydraulic pumps
 - Control devices.
 - **Field connections:**
 - All connections to the system and the electrical installations must be in accordance with all applicable codes.
 - The Carrier 30XV units are designed and built to ensure conformance with these codes. The recommendations of European standard EN 60204-1 (corresponds to IEC 60204-1) (machine safety - electrical machine components - part 1: General regulations) are specifically taken into account, when designing the electrical equipment**.
 - Appendix B of standard EN 60204-1 specifies the electrical characteristics used for the operation of the machines. Those specified below are applied to 30XAV units in addition to other information given in this document:
1. Physical environment***; The classification of the environment is specified in standard EN 60721 (equivalent to IEC 60721):
 - Outdoor installation
 - Ambient temperature range: Minimum temperature -20 °C up to +48 °C.
 - Altitude: Lower than or equal to 2000 m
 - Presence of hard solid: Class 4S2 (no significant dust present)
 - Presence of corrosive and polluting substances, class 4C2 (negligible)
 2. Power supply frequency variation: ± 2 Hz
 3. The neutral (N) line must not be connected directly to the unit (if necessary use a transformer).
 4. Overcurrent protection of the power supply conductors is not provided with the unit.
 5. The factory installed disconnect switch(es)/circuit breaker(s) is (are) of a type suitable for power interruption in accordance with EN 60947-3 (corresponds to IEC 60947-3).
 6. The units are designed for connection to TN networks (IEC 60364). In IT networks the use of noise filters integrated into the variable frequency drive(s) makes machine use unsuitable. In addition, the short-circuit holding current characteristics are modified. Provide a local earth, consult competent local organisations to complete the electrical installation.
7. Electromagnetic environment: Classification of the electromagnetic environment is described in standard EN 61800-3 (corresponds to IEC 61800-3):
 - Immunity to external interference defined by the second environment****
 - Interference emission as defined in category C3†
 - The harmonic currents generated by the variable frequency drives integrated in the 30XAV unit are a source of interference. An analysis may be required to verify if these interferences exceed the compatibility limits of the other devices connected to the same power supply network. The compatibility levels inside an electrical installation, that must be met at the in-plant coupling point (IPC) to which other loads are connected are described in standard 61000-2-4.
 - Two characteristics are required for this analysis:
 - The short-circuit ratio (Rsc) of the installation calculated at the in-plant coupling point (IPC).
 - The total harmonic current distortion rate (THDI), calculated for the machine at maximum capacity.
 - Leakage currents: If protection by monitoring the leakage currents is necessary to ensure the safety of the installation, the presence of additional leakage currents introduced by the use of variable frequency drives in the unit must be considered. In particular these protection devices shall be of reinforced immunity types and have a threshold not lower than 150 mA.
- NOTE: If particular aspects of an actual installation do not conform to the conditions described above, or if there are other conditions which should be considered, always contact your local Carrier representative.**
- * Depending on the size or options selected for the machine
- ** Generally the recommendations of IEC 60364 are accepted as compliance with the requirements of the installation directives. Conformance with EN 60204-1 is the best means of ensuring compliance with the Machinery Directive.
- *** The required protection level for this class is IP43BW (according to reference document IEC 60529). All 30XAV units are IP44CW and fulfil this protection condition.
- **** Example of installations of the second environment: Industrial zones, technical locations supplied from a dedicated transformer
- † Category C3 is suitable for use in an industrial environment and is not designed for use in a public low-voltage system that supplies residential locations. As an option, conformity with category C2 permits this type of installation.

5 - ELECTRICAL CONNECTION

Please refer to the certified dimensional drawings, supplied with the unit.

5.1 - Power supply

The power supply must conform to the specification on the chiller nameplate. The supply voltage must be within the range specified in the electrical data table. For connections refer to the wiring diagrams and the certified dimensional drawings.

WARNING: Operation of the chiller with an improper supply voltage or excessive phase imbalance constitutes abuse which will invalidate the Carrier warranty. If the phase imbalance exceeds 2% for voltage, or 10% for current, contact your local electricity supply at once and ensure that the chiller is not switched on until corrective measures have been taken.

5.2 - Voltage phase imbalance (%)

$$\frac{100 \times \text{max. deviation from average voltage}}{\text{Average voltage}}$$

Example:

On a 400 V - 3 ph - 50 Hz supply, the individual phase voltages were measured to be:

$$AB = 406 \text{ V}; BC = 399; AC = 394 \text{ V}$$

$$\begin{aligned} \text{Average voltage} &= (406 + 399 + 394)/3 = 1199/3 \\ &= 399.7 \text{ say } 400 \text{ V} \end{aligned}$$

Calculate the maximum deviation from the 400 V average:

$$\begin{aligned} (AB) &= 406 - 400 = 6 \\ (BC) &= 400 - 399 = 1 \\ (CA) &= 400 - 394 = 6 \end{aligned}$$

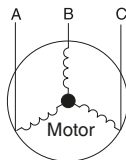

The maximum deviation from the average is 6 V. The greatest percentage deviation is: $100 \times 6/400 = 1.5 \%$

This is less than the permissible 2% and therefore acceptable.

5.3 - Power connection/disconnect switch

Standard:

- 30XAV 0500 to 0700 units have one connection point.
- 30XAV 0800 to 1150 units have two connection points (one with option 81).

5.4 - Recommended wire sections

Wire sizing is the responsibility of the installer, and depends on the characteristics and regulations applicable to each installation site. The following is only to be used as a guide-line, and does not make Carrier in any way liable. After wire sizing has been completed, using the certified dimensional drawing, the installer must ensure easy connection and define any modifications necessary on site.

The connections provided as standard for the field-supplied power entry cables to the general disconnect/isolator switch are designed for the number and type of wires, listed in column 2 of the table on the next page.

The calculations are based on the maximum machine current (see electrical data tables).

The calculations of favourable and unfavourable cases are based on the maximum current for each unit (see electrical data tables). For the design the standardised installation methods in accordance with IEC 60364 are used: PVC (70 °C) or XLPE (90 °C) insulated cables with copper core; arrangement to comply with table 52c of the above standard. The maximum temperature is 46 °C. The given maximum length is calculated to limit the voltage drop to 5%.

IMPORTANT: Before connection of the main power cables (L1 - L2 - L3) on the terminal block, it is imperative to check the phase rotation of the 3 phases before proceeding to the connection on then terminal block or the main disconnect/isolator switch.

5.5 - Power cable entry

The power cables can enter the 30XAV control box from below or from the unit side: refer to unit drawings. For 30XAV unit sizes 500 to 1150 the control box that includes the power supply cable connection terminal is located in the lower part of the unit. In this case the control box is raised by 120 mm compared to the lowest point of the chassis.

The cable entry point depends on the unit configuration:

1. Unit raised from the ground (e.g. installation on support rails): It is recommended to enter the power cables from below the control box. A removable aluminium plate below the control box allows introduction of the cables.
2. Unit placed on the ground: For power cable entry from below the control box ensure that the cable bend radius is compatible with the connection space available in the control box. If not, an aluminium plate on the control box face allows introduction of the cables.

For units with three circuits with option 81 (single power connection point) the connection must be made from below the unit.

IMPORTANT: Check the cable bend radius for cable entry into a control box, located in the lower part of the unit.

Refer to the certified dimensional drawing for the unit.

Table of minimum and maximum wire sections (per phase) for connection to 30XAV units

30XAV	Max. connectable section*	Calculation favourable case:			Calculation unfavourable case:		
		- Suspended aerial lines (standardised routing No. 17) - XLPE insulated cable			- Conductors in conduits or multi-conductor cables in closed conduit (standardised routing No. 41) - PVC insulated cable, if possible		
	Section	Section**	Max. length for voltage drop <5%	Cable type	Section**	Max. length for voltage drop <5%	Cable type***
	mm ² (per phase)	mm ² (per phase)	m		mm ² (per phase)	m	
500	2x240	1x185	260	XLPE	2x185	450	PVC
600	2x240	1x240	280	XLPE	2x240	480	PVC
700	2x240	1x240	250	XLPE	2x185	350	XLPE
800	2x240/2x240	1x150/1x150	260	XLPE	2x185/2x185	550	PVC
950	2x240 / 2x240	1 x 240 / 1 x 150	240	XLPE	2 x 185 / 2 x 120	380	XLPE
1050	2x240 / 2x240	1 x 240 / 1 x 240	240	XLPE	2 x 185 / 2 x 185	410	XLPE
1150	2x240 / 2x240	2 x 120 / 2 x 120	260	XLPE	2 x 2 40 / 2x 240	450	XLPE

Option 81

800 - 1150 4 x 240

* Connection capacities actually available for each machine, defined according to the connection terminal size, the control box access opening size and the available space inside the control box.
 ** Selection simulation result considering the hypothesis indicated.
 *** If the maximum calculated section is for an XLPE cable type, this means that a selection based on a PVC cable type can exceed the connection capacity actually available. Special attention must be given to the selection.

5.6 - Field control wiring

IMPORTANT: Field connection of interface circuits may lead to safety risks: Any control box modification must maintain equipment conformity with local regulations. Precautions must be taken to prevent accidental electrical contact between circuits supplied by different sources:

- **The routing selection and/or conductor insulation characteristics must ensure dual electric insulation.**
- **In case of accidental disconnection, conductor fixing between different conductors and/or in the control box prevents any contact between the conductor ends and an active energised part.**

Refer to the 30XAV Touch Pilot control manual and the certified electric wiring diagram provided with the unit for the field control wiring of the following features:

- Remote on/off switch
- Demand limit external switch
- Remote dual set point
- Alarm, alert and signals
- Evaporator pump control
- Heat reclaim condenser pump control (option)
- Set point reset via outside air temperature sensor
- Various interlocks on the Energy Management Module (EMM) board.

Connections to the client communication bus

- The connection to the CCN bus is carried out using connectors provided for this purpose inside the control box. Two connectors are provided to allow both permanent and service connections.
- Permanent connections to an Ethernet bus or to a USB port are made via the connectors on the touch screen interface.

A shielding clamp for the cable from the system is provided near the permanent bus connectors.

5.7 - Electric and power reserve for the user

After all possible options have been connected, the TC transformer ensures a power supply reserve of 1 A under 24 Vac that can be used for the on-site control cabling.

As an option, a second TC transformer powers a 230V, 50Hz circuit can be used for charging a laptop battery (maximum current 0.8 A). A standard CEE7/17, type E connector is provided. This circuit is protected by a 10mA earth leakage detector.

6 - APPLICATION DATA

6.1 - Operating range

30XAV standard unit

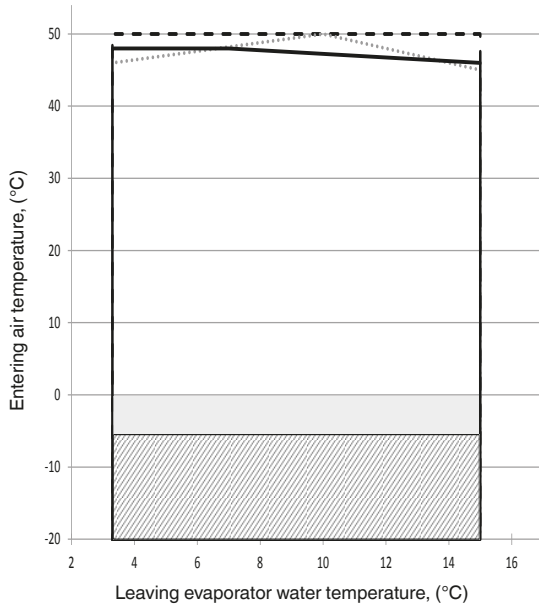

- Partial load > 50%
- Partial load < 50%
- Full load

Note:

- Evaporator $\Delta T = 5K$
- These ranges are given by way of indication. Verify the operating range from the Carrier electronic catalogue.

Legend

- Operating range, standard unit 30XAV
- Below 0 °C air temperature the unit must either be equipped with the evaporator freeze protection option 41A, or the water loop must be protected against freeze by using a freeze protection solution (by the installer).
- For start-ups with air temperature below -5 °C, the machine must be equipped with option 41A.

Evaporator water temperature	°C	Minimum	Maximum
Entering water temperature at start-up	-	-	45**
Leaving water temperature during operation		6.8	21
Water outlet in operation		3.3*	15

NOTE: The use of brine or antifreeze protection option is required if the water outlet temperature is below 4 °C

Condenser air temperature	°C		
Storage		-20 °C	68
Operation			
Standard unit		-20 °C***	50**

NOTE: If the air temperature is below 0 °C, a glycol/water solution or the freeze protection option must be used.

- * According to the type of installation and air temperature
- ** Operating at partial load.
- *** Option 41A mandatory for start-ups below -5 °C.

6.2 - Minimum chilled water flow (units without hydronic module)

The minimum chilled water flow is shown in the table on the next page. If the system flow is less than this, the evaporator flow can be recirculated, as shown in the diagram.

For minimum chilled water flow rate

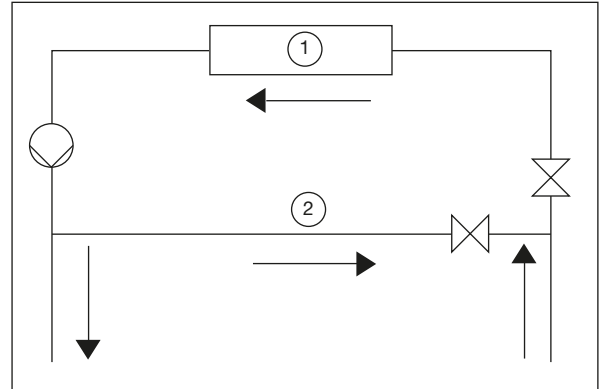

Legend:

- 1 Evaporator
- 2 Recirculation

6.3 - Maximum chilled water flow (units without hydronic module)

The maximum chilled water flow is shown in the table on the next page. If the system flow exceeds the maximum value, it can be bypassed as shown in the diagram.

For maximum chilled water flow rate

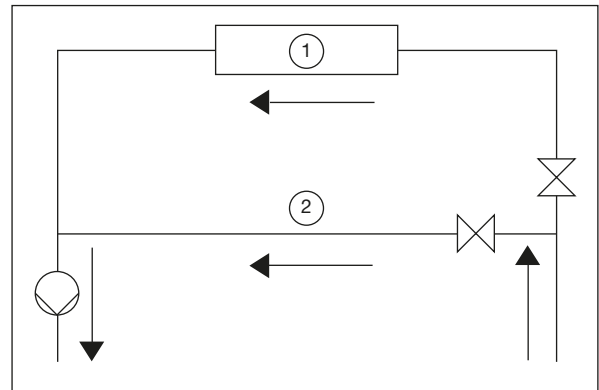

Legend:

- 1 Evaporator
- 2 Bypass

6.4 - Variable flow evaporator

Variable evaporator flow can be used as standard with 30XAV chillers. The chillers maintain a constant leaving water temperature under all flow conditions. For this to happen, the flow rate must be higher than the minimum flow given in the table of permissible flow rates and must not vary by more than 10% per minute.

If the flow rate changes more rapidly, the system should contain a minimum of 6.5 litres of water per kW instead of 3.25 l/kW.

The flow can also be controlled by the unit through option 299 : Variable Water Flow Control. This option allows the unit to control an external pump in order to maintain a constant inlet/outlet temperature difference, a constant outlet pressure or an unoccupied mode.

6.5 - System minimum water volume

Whichever the system, the water loop minimum capacity is given by the formula:

$$\text{Capacity} = \text{Cap (kW)} \times \text{N litres}$$

Application	N
Normal air conditioning	3.25
Process type cooling	6.5

Where Cap is the nominal system cooling capacity (kW) at the nominal operating conditions of the installation.

This volume is necessary for stable operation and accurate temperature control.

It is often necessary to add a buffer water tank to the circuit in order to achieve the required volume. The tank must itself be internally baffled in order to ensure proper mixing of the liquid (water or brine). Refer to the examples below.

Connection to a buffer tank

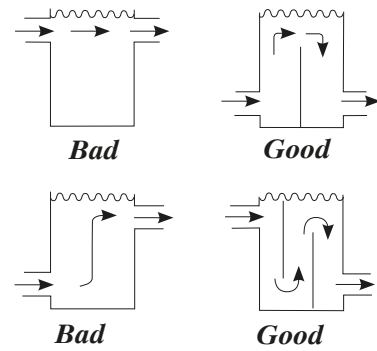

6.6 - Evaporator water flow rate

30XAV	Evaporator water flow rate, l/s*			
	Dual pass		Single pass	
	Minimum	Maximum	Minimum	Maximum
500	7.1	51.5	17	57.6
600	8.9	63.1	21	69.1
700	8.9	63.1	21	80.6
800	11.2	73.1	25.5	92.1
950	12.4	82.2	28.3	109.4
1050	13.1	93.9	31.1	120.9
1150	15.4	95.5	34.2	132.5

* Standard evaporator and coolant = water

6.7 - Evaporator pressure drop curve

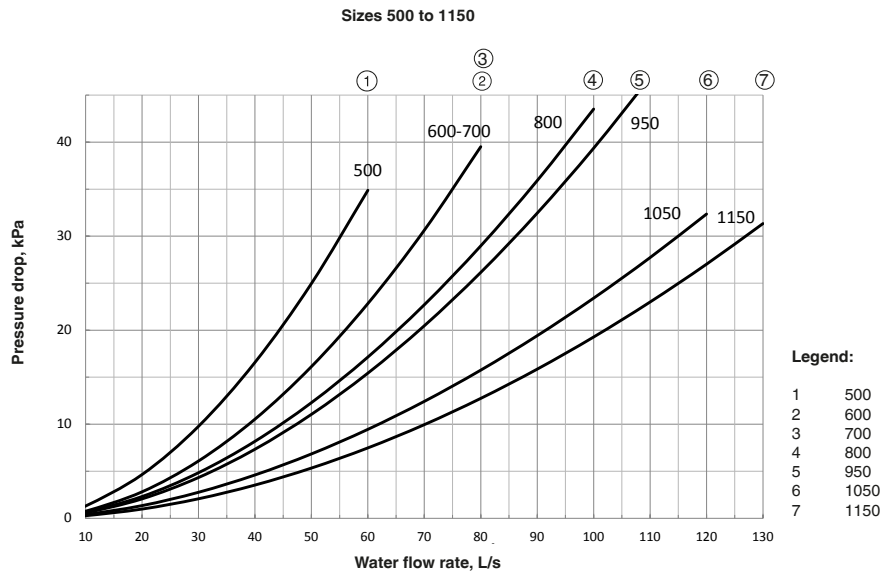

Note: Standard evaporator and coolant = water

7 - WATER CONNECTIONS

ATTENTION: Before carrying out any water connections install the water box drain plugs (one plug per water box in the lower section - supplied in the control box).

For dimensions and position of the water inlet and outlet connections refer to the certified dimensional drawings supplied with the unit. The water pipes must not transmit any radial or axial force to the heat exchangers nor any vibration.

The water supply must be analysed and appropriate filtering, treatment, control devices, isolation and bleed valves and circuits built in, to prevent corrosion, fouling and deterioration of the pump fittings.

Carrier recommendations on heat exchange fluids:

1. No NH_4^+ ammonium ions in the water, they are very detrimental for copper. This is one of the most important factors for the operating life of copper piping. A content of several tenths of mg/l will badly corrode the copper over time.
2. Cl^- Chloride ions are detrimental for copper with a risk of perforations by corrosion by puncture. If possible keep below 125 mg/l.
3. SO_4^{2-} sulphate ions can cause perforating corrosion, if their content is above 30 mg/l.
4. No fluoride ions (<0.1 mg/l).
5. No Fe^{2+} and Fe^{3+} ions with non negligible levels of dissolved oxygen must be present. Dissolved iron < 5 mg/l with dissolved oxygen < 5 mg/l.
6. Dissolved silicon: silicon is an acid element of water and can also lead to corrosion risks. Content < 1 mg/l.
7. Water hardness: > 0.5 mmol/l. Values between 1 and 2.5 can be recommended. This will facilitate scale deposit that can limit corrosion of copper. Values that are too high can cause piping blockage over time. A total alkalimetric titre (TAC) below 100 is desirable.
8. Dissolved oxygen: Any sudden change in water oxygenation conditions must be avoided. It is as detrimental to deoxygenate the water by mixing it with inert gas as it is to over-oxygenate it by mixing it with pure oxygen. The disturbance of the oxygenation conditions encourages destabilisation of copper hydroxides and enlargement of particles.
9. Electric conductivity 10-600 $\mu\text{S}/\text{cm}$.
10. pH: Ideal case of neutral pH at 20-25 °C (7.5 < pH < 9).

If the water circuit must be emptied for longer than one month, the complete circuit must be placed under nitrogen charge to avoid any risk of corrosion by differential aeration.

CAUTION: Filling, completing and draining the water circuit charge must be done by qualified personnel, using the air purges and materials that are suitable for the products.

Charging and removing heat exchange fluids should be done with devices that must be included on the water circuit by the installer. Never use the unit heat exchangers to add heat exchange fluid.

7.1 - Operating precautions

The water circuit should be designed to have the least number of elbows and horizontal pipe runs at different levels. Below the main points to be checked for the connection:

- Comply with the water inlet and outlet connections shown on the unit.
- Install manual or automatic air purge valves at all high points in the circuit(s).
- Use a pressure reducer to maintain pressure in the circuit(s) and install a relief valve as well as an expansion tank.
- Units supplied with hydronic module include a chilled circuit relief valve. Units supplied with option 293 include an expansion tank.
- Install thermometers in both the entering and leaving water connections.
- Install drain connections at all low points to allow the whole circuit to be drained.
- Install stop valves, close to the entering and leaving water connections.
- Use flexible connections to reduce the transmission of vibrations.
- Insulate all pipework, after testing for leaks, both to reduce heat gains and to prevent condensation.
- Cover the insulation with a vapour barrier.
- Where there are particles in the fluid that could foul the heat exchanger, a screen filter should be installed ahead of the pump. The mesh size of the filter must be 1.2 mm (see 'Typical water circuit diagram').
- Before the system start-up verify that the water circuits are connected to the appropriate heat exchangers (e.g. no reversal between evaporator and condenser).
- Do not introduce any significant static or dynamic pressure into the heat exchange circuit (with regard to the design operating pressures).
- Before any start-up verify that the heat exchange fluid is compatible with the materials and the water circuit coating.
- In case additives or other fluids than those recommended by Carrier are used, ensure that the fluids are not considered as a gas, and that they belong to class 2, as defined in directive 2014/68/EU.

7.2 - Victaulic water connections

7.2.1 - Hydronic connections

Inlet/outlet diameters

30XAV		500	600	700	800	950	1050	1150
Standard								
Nominal Diameter	in	5	6	6	6	6	8	8
Actual External Diameter	mm	141.3	168.3	168.3	168.3	168.3	219.1	219.1
Options 100C								
Nominal Diameter	in	6	6	6	6	6	8	8
Actual External Diameter	mm	168.3	168.3	168.3	168.3	168.3	219.1	219.1
Options 116								
Nominal Diameter	in	5	5	-	-	-	-	-
Actual External Diameter	mm	141.3	141.3	-	-	-	-	-

The hydronic module options are compatible only with closed heat exchange fluid loops.
The use of hydronic modules on open loop system is prohibited.

Typical diagram of the hydronic circuit with the hydronic module

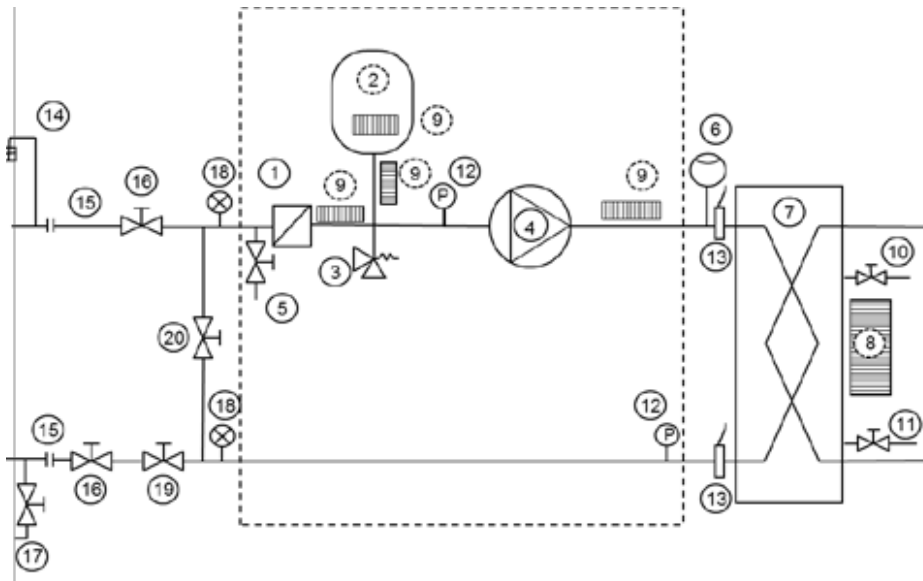

Legend:

Components of the unit and hydronic module

- 1 Screen filter (mesh opening 1.2mm = 20 mesh), Victaulic
- 2 Expansion tank (option 293)
- 3 Relief valve
- 4 Available pressure water pump
- 5 Water drain valve
- 6 Flow switch for the evaporator
- 7 Evaporator
- 8 Evaporator heater for freeze protection (option 41A & 41B)
- 9 Heater for freeze protection of hydronic module (option 41 B)
- 10 Air purge (evaporator)
- 11 Water purge (evaporator)
- 12 Pressure sensor
- 13 Water temperature probe
- Installation components
- 14 Air purge
- 15 Flexible connection
- 16 Shut-off valve
- 17 Charge valve
- 18 Pressure gauge
- 19 Water flow control valve
- 20 Bypass valve for freeze protection (if shut-down valves -item 16 - are closed)
- Hydronic module (option)

Notes :

- The unit must be protected against freeze.
- The evaporator is protected against freeze with electric heaters (option 41A factory installed)
- The hydronic module of the unit and the evaporator are protected against freeze with electrical heaters (option 41B factory installed)
- The pressure sensors are assembled on connections without schraeder. Depressurized and empty the network before intervention

7.2.2 - Piping limitations

Depending on the unit size and options, the space between water box connections and the nearest component can vary. This results in piping limitations. In the case of straight pipes, the space remaining available for pipe insulation are listed in the table below.

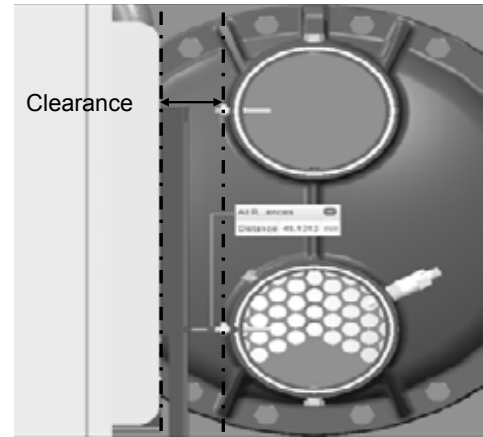

Straight pipes clearance with nominal diameter

XAV	500	600	700	800	950	1050	1150
Standard unit							
Inlet (mm)	118	105	105	25	49	23	23
Outlet (mm)	118	105	105	25	49	23	23
Unit with option 100C							
Inlet (mm)	118	105	105	25	49	23	23
Outlet (mm)	Elbow mandatory	Elbow mandatory	Elbow mandatory	Elbow mandatory	Elbow mandatory	Elbow mandatory	Elbow mandatory
Unit with option 107							
Inlet (mm)	Elbow mandatory	Elbow mandatory			Elbow mandatory	Elbow mandatory	Elbow mandatory
Outlet (mm)	Elbow mandatory	Elbow mandatory			Elbow mandatory	Elbow mandatory	Elbow mandatory

For installation that requires thicker insulation, it is advised to use a pipe reduction or an elbow to avoid the closest component. When straight pipe is not possible, use an elbow. Check elbow connection limitation in the table below.

Elbow connection

XAV	500	600	700	800	950	1050	1150
Standard unit							
Inlet (mm)	Check dimension	Check dimension	Check dimension	OK	OK	OK	OK
Outlet (mm)	Check dimension	Check dimension	Check dimension	OK	OK	OK	OK
Unit with option 100C							
Inlet (mm)	Check dimension	Check dimension	Check dimension	OK	OK	OK	OK
Outlet (mm)	OK	OK	OK	OK	OK	OK	OK
Unit with option 107							
Inlet (mm)	Check dimension	Check dimension			Check dimension	Check dimension	Check dimension
Outlet (mm)	Check dimension	Check dimension			Check dimension	Check dimension	Check dimension

Check dimension : it is possible to install an elbow, but space available is limited and choice of the elbow size must be done in accordance with the dimensional drawings.

7.3 - Flow detection

Evaporator flow switch and chilled water pump interlock

IMPORTANT: It is mandatory that the water flow switch must be energised while the machine is in operation. Failure to follow this instruction will void the Carrier guarantee.

The water flow switch is installed on the evaporator water inlet and adjusted by the controls, based on unit size and application. If adjustment is necessary, it must be carried out by qualified personnel trained by Carrier Service.

Terminals 34 and 35 are provided for field installation of the chilled water pump interlock (auxiliary contact for pump operation to be wired on site).

7.4 - Evaporator water box bolt tightening

The evaporator is of the shell and tube type with removable water boxes to facilitate cleaning. Re-tightening or tightening must be done in accordance with the illustration below.

Water box tightening sequence

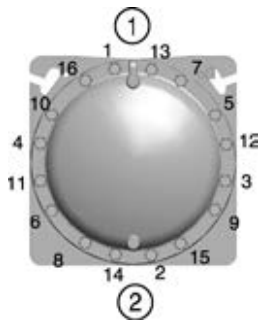

Legend:

- ① Sequence 1 : 1 2 3 4
Sequence 2 : 5 6 7 8
Sequence 3 : 9 10 11 12
Sequence 4 : 13 14 15 16
- ② Tightening torque
Bolt size
M16 - 171 - 210 Nm

NOTE: Before this operation we recommend draining the circuit and disconnecting the pipes to be sure that the bolts are correctly and uniformly tightened.

7.5 - Freeze protection

The evaporator, the pipes and the hydronic module pump might be damage by freeze. The components of the unit (evaporator and hydronic module) will be protected by following the recommendations below. Protection of the remainder of the system is the responsibility of the installer. Damage due to freezing is not covered by the warranty.

7.5.1 - Standard machine

If the chiller or the water piping is in an area where the ambient temperature can fall below 0 °C it is recommended to add an antifreeze solution (45% maximum, 40% in case of unit with hydronic module) to protect the unit and the water piping to a temperature of 10 K below the lowest temperature likely to be reached at the installation site. Use only antifreeze solutions, approved for heat exchanger duty. If the system is not protected by an antifreeze solution and will not be used during freezing weather conditions, draining of the cooler and outdoor piping is mandatory. Damage due to freezing is not covered by the warranty.

7.5.2 - Optional evaporator freeze protection (30XAV)

In cases where it is not possible to apply the recommendations in paragraph 7.5.1, the units can be equipped with heaters to protect the evaporator against freeze (option 41A or 41B with hydronic kit). The antifreeze solution and heaters can be combined.

Freeze protection of units with hydronic modules requires that water circulates in the hydraulic circuit. The unit mounted pump will start, automatically, periodically.

To verify that the heater circuit is 'live'. See Chapter 10 - "Standard maintenance".

IMPORTANT: Depending on the climatic conditions in your area you must:

- Add ethylene glycol with an adequate concentration to protect the installation up to a temperature of 10 K below the lowest temperature likely to occur at the installation site.
- If the unit is not used for an extended period, it is recommended to drain it, and as a safety precaution add ethylene glycol to the heat exchanger, using the drain point located near the water inlet connection (a purge connection is available somewhere on the heat exchanger water box in case the machine is not perfectly level).
- At the start of the next season, refill the unit with water and add an inhibitor.
- For the installation of auxiliary equipment, the installer must comply with basic regulations, especially for minimum and maximum flow rates, which must be between the values listed in the operating limit table (application data).

7.6 - Protection against cavitation (with option 116)

To ensure the durability of pumps fitted with hydronic modules, the control algorithm of 30XAV units includes protection against cavitation. A pressure below 80 kPa will prevent the unit from starting, or will cause a shutdown. To obtain an adequate pressure, it is recommended:

- to pressurise the hydronic circuit between 100 kPa (1 bar) and 400 kPa (4 bars) maximum at the pump inlet
- to clean the hydronic circuit during water filling or during its modification
- to regularly clean the screen filter.

7.7 - Operation of two units in master/slave mode (option 58)

As standard, the control of a master/slave assembly is from the entering water temperature and does not require any additional sensors (standard configuration). It can also be controlled from the leaving water temperature, in this case two additional sensors must be added on the common piping.

All parameters, required for the master/slave function must be configured using the Configuration menu MST_SLV. All remote controls of the master/slave assembly (start/stop, set point, load shedding, etc.) are controlled by the unit configured as master and must only be applied to the master unit.





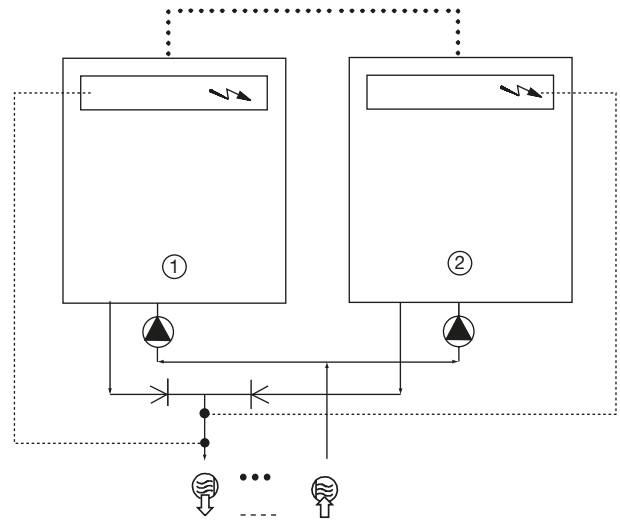

Each unit controls its own water pump. If there is only one common pump, and in cases with variable flow, isolation valves must be installed on each unit. They will be activated at the opening and closing controlled by the individual units using the water pump control signals. Refer to the 30XAV Touch Pilot control manual for a more detailed explanation.

WARNING: Both units must have option 58 to allow the Master/Slave operation.

30XAV with configuration: Leaving water control



Legend:

- 1 Master unit
- 2 Slave unit
-  Control boxes of the master and slave units
-  Water inlet
-  Water outlet
-  Water pumps for each unit (included as standard for units with hydronic module)
-  Additional sensors for leaving water control, to be connected to channel 1 of the slave boards of each master and slave unit
-  CCN communication bus
-  Connection of two additional sensors

8 - UNIT WITH HYDRONIC KIT

8.1 - Available static pressure for the system

Data applicable for fresh water, 20°C

- In case of use of the glycol, the maximum water flow is reduced
- Glycol percentage is limited to 40%
- For ambient temperature over 40°C, maximum water flow is limited

Low pressure pumps (options 116T/116U)

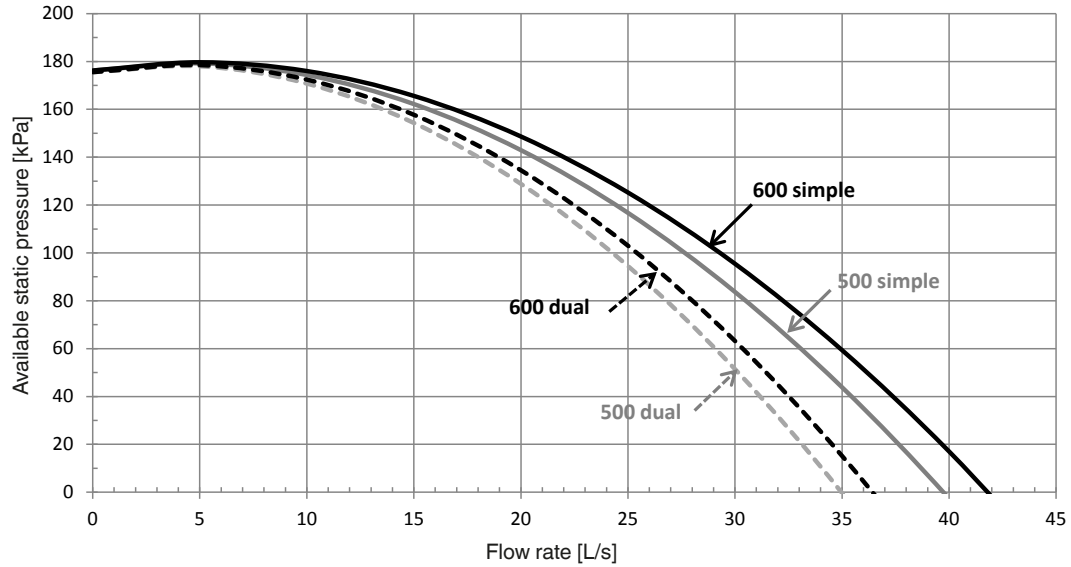

High pressure pumps (options 116R/116S)

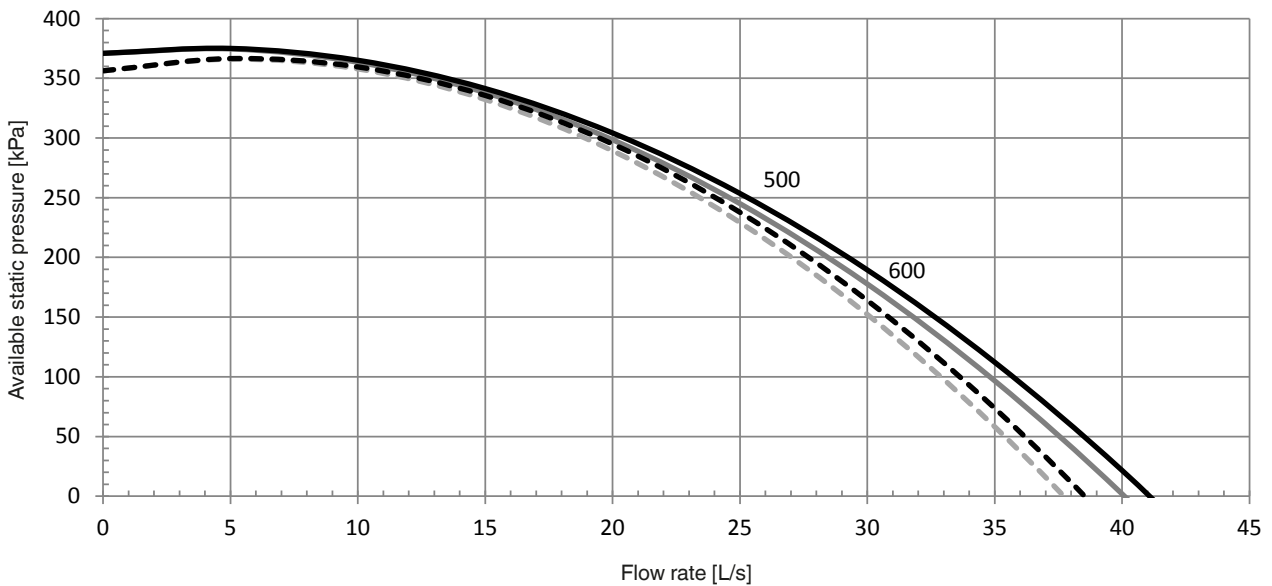

8.2 - NPSH (Net Positive Suction Head) required ; Hydronic module option

Design hydronic circuit in order to guarantee that NPSH (Net Positive Suction Head) is higher or equal to required NPSH + 50 kPa.

Low pressure pumps (options 116T/116U)

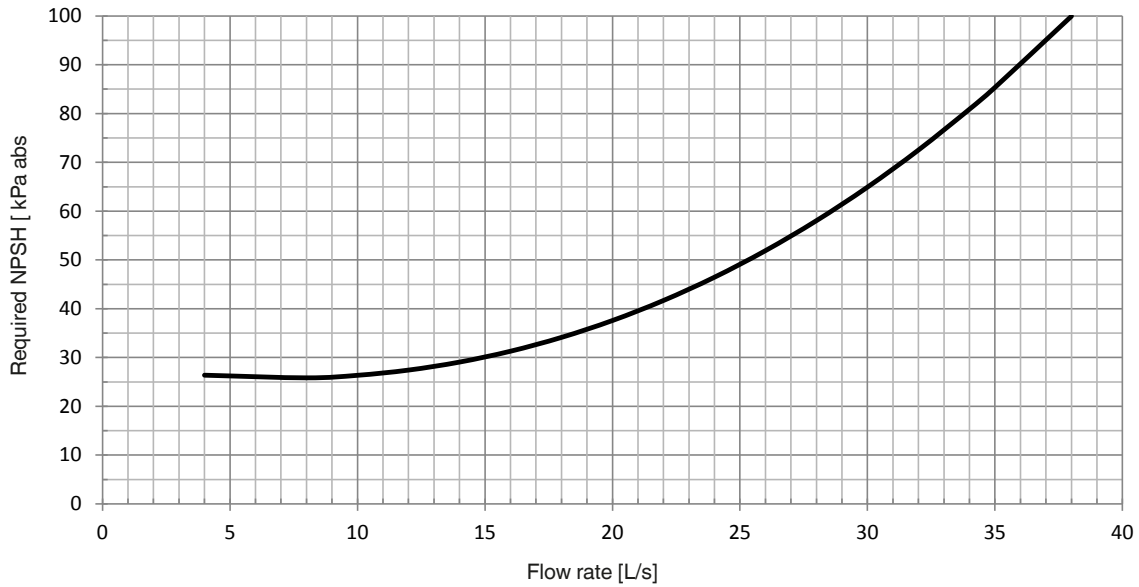

High pressure pumps (options 116R/116S)

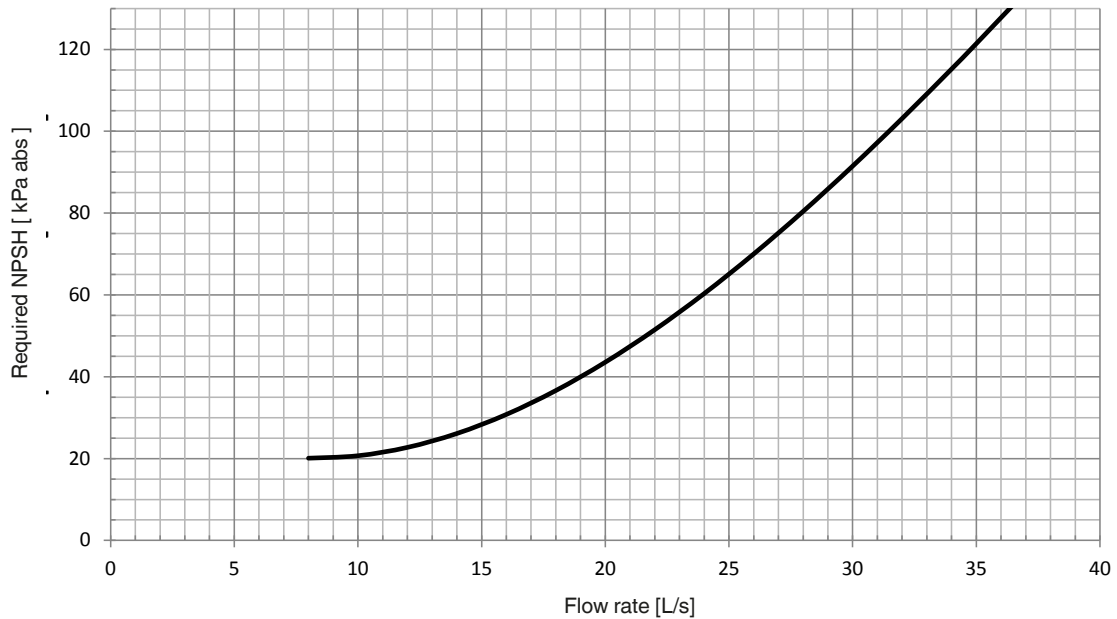

8.3 - Flow rate and cooling capacity calculations

Units with hydronic module enable direct monitoring of flow rate and cooling capacity through IHM (refer to 30XAV control manual).

Fluid pressure is measured by pressure sensors fitted at pump inlet and unit outlet. The system calculates the flow rate corresponding to measured differential pressure.

Combined with temperature difference between evaporator inlet and outlet, this flow rate calculation permits to provide a monitoring of cooling capacity.

Calculations are only applicable with fresh water. In case of brine solution (ex: glycol) other than fresh water, flow and cooling capacity provided won't be accurate.

These data are given for indicative purpose to user and may vary depending on hydronic circuit fouling and proper operation of the pump. Carrier does not undertake the accuracy of this information.

9 - MAJOR SYSTEM COMPONENTS AND OPERATION DATA

9.1 - Compressor

30XAV units use 06T geared twin-screw compressors equipped with a variable capacity slide valve and controlled by variable frequency drive.

Compressor capacity control is by speed variation and then slide valve modulation.

The combination of these two control modes permits fine control of the unit capacity between 10% and 100%.

ATTENTION: Depending on operating conditions, unit might have a different minimum capacity or cycle.

9.2 - Oil filter

The 06T screw compressor has an independent oil filter attached to the oil separator. This filter is field replaceable.

9.3 - Refrigerant

The 30XAV water chiller operates only with refrigerant R134a.

9.4 - Lubricant

The 06T screw compressor is approved for use with the following lubricants:

- Castrol Icematic SW220 (Carrier specification PP47-32)
- Lubrizol Emkarate RL220H (Carrier specification PP47-13)

ATTENTION: Too much oil in the circuit can cause a failure.

9.5 - Oil supply solenoid valve

An oil supply solenoid valve is installed on the oil return line as standard to isolate the compressor from oil flow when the compressor is not operating. The oil solenoid valve is field replaceable.

9.6 - Suction and economiser screens

To increase the reliability of the compressor, a screen has been incorporated as a standard feature into suction and economiser inlets of the compressor.

9.7 - Pressure vessels

9.7.1 - General

Observe the following guidelines during operation, testing and certification:

- Follow the regulations on monitoring pressurised equipment.
- It is normally required that the user or operator sets up and maintains a monitoring and maintenance file.
- If there are no regulations or to complement them follow the guidance programmes of EN 378.
- If they exist follow local professional recommendations.
- Regularly inspect the condition of the coating (paint) to detect blistering resulting from corrosion. To do this, check a non-insulated section of the vessel or joint in the insulation.
- Regularly check for possible presence of impurities (e.g. silicon grains) in the heat exchange fluids. These impurities may cause erosion and/or corrosion.
- Install appropriate filtration in the chilled fluid circuit. Carry out internal inspections as described in EN 378-2 Annexe C.
- In case of re-testing please refer to the maximum operating pressure given on the unit nameplate.
- The reports of periodical checks by the user or operator must be included in the supervision and maintenance file.

9.7.2 - Repair

Any repair or modification, including the replacement of parts:

- Must follow local regulations and be made by qualified operators and in accordance with qualified procedures, this include changing the heat exchanger tubes.
- Must be made in accordance with the instructions of the original manufacturer. Repair and modification that necessitate permanent assembly (soldering, welding, expanding, etc.) must be made using the correct procedures and by qualified operators.
- An indication of any modification or repair must be shown in the monitoring and maintenance file.

9.7.3 - Recycling

The unit is wholly or partly recyclable. After use it contains refrigerant vapours and oil residue. It is coated with paint.

9.7.4 - Operating life

This unit is designed for:

- Prolonged storage of 15 years under nitrogen charge with a temperature difference of 20 K per day.
- 452000 cycles (start-ups) with a maximum difference of 6 K between two neighbouring points in the vessel, based on 6 start-ups per hour over 15 years at a usage rate of 57%.

9.7.5 - Corrosion allowances

Gas side: 0 mm

Heat exchange fluid side: 1 mm for tubular plates in lightly alloyed steels, 0 mm for stainless steel plates or plates with copper-nickel or stainless steel protection.

9.7.6 - Evaporator

30XAV chillers use a flooded multi-tube evaporator. The water circulates in the tubes and the refrigerant is on the outside in the shell. One vessel is used to serve both refrigerant circuits. There is a centre tube sheet which separates the two refrigerant circuits. The tubes are 3/4" diameter copper with an enhanced surface inside and out. There is just one water circuit with two water passes (one pass when 100C is selected).

The evaporator has been tested and stamped in accordance with the applicable pressure code. The maximum maximum standard relative operating pressure is 2100 kPa for refrigerant side and 1000 kPa for water side. These pressures can be different depending on the regulation and the code applied.

The evaporator has a thermal insulation of 19 mm thick polyurethane foam, aluminium cladding may be fitted as an option and is equipped with a water vent and purge.

The water connection of the heat exchanger is a Victaulic connection. As an option the evaporator is available with freeze protection (evaporator freeze protection option).

The products that may be added for thermal insulation of the containers during the water piping connection procedure must be chemically neutral in relation to the materials and coatings to which they are applied. This is also the case for the products originally supplied by Carrier.

9.7.7 - Oil separator

In these units, the oil separator is a pressure vessel that is mounted under the outside vertical condenser coils. Discharge gas at the compressor outlet is directed towards the bottom of the oil separator and most of the oil separates from the gas by strong deceleration and by gravity. The gas then flows through a wire mesh screen where the remaining oil is separated by coalescence and flows to the bottom of the vessel. The gas is now free from oil and leaves the vessel at the top towards the condenser.

The oil separator is equipped with a trace heater regulated by the unit controls.

9.7.8 - Assembly function

The assembly function includes a liquid line valve, a filter drier, two EXVs, a plate heat exchanger as well as protection devices (seal or valve).

At the condenser outlet a part of the liquid is expanded via the secondary EXV in one of the heat exchanger port and then returns as gas at the compressor economiser. This expansion increases the sub-cooling of the bulk of the liquid refrigerant which then flows into the evaporator via the main EXV. This increases both the capacity and efficiency of the system.

9.8 - High-pressure safety switch

30XAV units are equipped with high-pressure safety switches.

In accordance with the applicable code the high-pressure switches with manual reset, called PZH (former DBK), may be backed up by high-pressure switches that require resetting with a tool. The high-pressure switches that require resetting with a tool are called PZHH (former SDBK). If a PZHH cuts out, the corresponding PZH in the same compressor is faulty and must be replaced. The PZHH must be reset with a blunt tool with a diameter of less than 6 mm. Insert this tool into the opening on the pressure switch and push the reset.

These pressure switches are located at the discharge of each compressor.

9.9 - Condensers

30XAV coils are all-aluminium micro-channel condensers.

9.10 - Fans

The fans are axial Flying Bird fans equipped with rotating shroud and made of composite recyclable material. Each motor is fixed with transverse supports. The motors are three-phase, with permanently lubricated bearings and insulation class F (level IP55).

All fans in the same refrigerant circuit are controlled by one or two variable speed drives. Therefore, they operate together at the same rotational speed. The rotational speed at full load or partial load of each circuit is controlled by an algorithm that continuously optimises the condensing temperature to obtain the best energy efficiency (EER) whatever the operating conditions.

9.10.1 - Fan motor electrical protection

The motors of a same circuit are electrically protected by the variable frequency drive in case of short-circuit, locked rotor or general overload. Each variable frequency drive follows a variable current characteristic, based on the frequency from 5 to 50 Hz and the number of fans controlled.

In case of fan failure (in open circuit), the variable frequency drive will automatically detect the problem and send an alert to the user interface. Refer to the 30XAV control manual for the list of alarms specific to this option.

According to the Regulation No. 327/2011 implementing directive 2009/125/EC with regard to ecodesign requirements for fans driven by motors with an electric input power between 125 W and 500 kilowatts.

Product		30XAV
Global fan efficiency	%	41
Measurement category		A
Efficiency category		Static
Energy efficiency target N(2015)		N(2015) 40
Efficiency level at the optimum efficiency point		45.7
Variable frequency drive		YES
Year of manufacture		See label on the unit
Fan manufacturer		Simonin
Motor manufacturer		Leroy Somer
Fan reference		00PSG000000100A
Motor reference		00PPG000494700A
Nominal power of the motor	kW	1.84
Flow rate	m ³ /s	4.15
Pressure at optimum energy efficiency	Pa	170
Speed	rpm	950
Specific ratio		1.002
Relevant information to facilitate the disassembly, recycling or removal of the product at the end of the life		See Maintenance Manual
Relevant information to minimise the impact on the environment		See Maintenance Manual

According to the Regulation No. 640/2009 and amendment 4/2014 implementing directive 2009/125/EC with regard to ecodesign requirement for electric motor.

Motor type		Asynchronous
Number of poles		6
Nominal input frequency	Hz	50
Nominal voltage	V	400
Number of phases		3
Motor included in the application domain of the regulation 640/2009 & amendment 4/2014		NO
Sales leaflet for exemption		Article 1.2.c).(ii)
Ambient air temperature for which the motor is specifically designed	°C	70

9.11 - Electronic expansion valve (EXV)

The EXV is equipped with a stepper motor (2785 to 3690 steps, depending on the model) that is controlled via the EXV board.

The EXV is also equipped with a sightglass that permits verification of the mechanism movement and the presence of the liquid seal.

9.12 - Moisture indicator

Located on the EXV, permits control of the unit charge and indicates moisture in the circuit. The presence of bubbles in the sight-glass indicates an insufficient charge or non-condensables in the system. The presence of moisture changes the colour of the indicator paper in the sight-glass.

9.13 - Filter drier

The role of the filter drier is to keep the circuit clean and moisture-free. The moisture indicator shows, when it is necessary to change the element. A difference in temperature between the filter inlet and outlet shows that the element is dirty.

9.14 - Sensors

The unit uses thermistors and pressure transducers to monitor and control the operation of the system. Refer the Touch Pilot Control IOM for more detailed information.

9.15 - Service valve (option 92)

The unit can be equipped with optional service valves to facilitate maintenance and repair operations.

If option 92 is ordered, each refrigerant circuit will be supplied with shut-off valves on the compressor economiser, discharge and suction lines.

ATTENTION: The compressor suction valve must be used without pressure difference at the terminals. If there is a pressure difference, leak-tightness at the valve may be lost and the valve can even fail altogether.

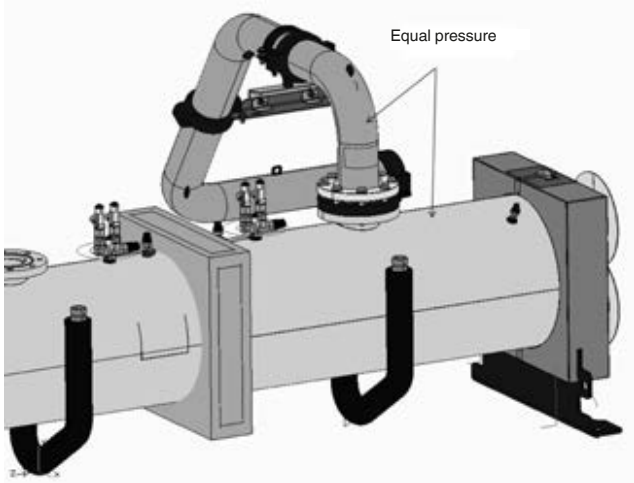

9.16 - Variable frequency drive

The 30XAV units are fitted with a variable frequency drive that allows adjustment the capacity of the compressor by varying the speed of the motor within the frequency range of 27.5-60 Hz.

Variable speed is produced by generating a controlled voltage waveform, on which both frequency and voltage are adjustable (via Pulse Width Modulation).

The compressor start-up/stop and the frequency setpoint (within the acceptable range) is managed through RS485 communication via LEN Protocol by the "Carrier Controller".

One of the other features of the "variable frequency drive" is to ensure the safety stop function of the unit via HP switches wired to the digital inputs. This safety function follows the EN ISO 13849-1 standard in compliance with the requirements of the directive of equipments under pressure (DESP).

10 - OPTIONS

Options	No.	Description	Advantages	Utilisation
IP54 control box	20A	Increased leak tightness of control boxes	Protects the inside of the electrical box from dusts and sand. In general this option is recommended for installations in polluted environments	500-1150
Grilles and enclosure panels	23	Metal grilles on the 4 unit sides, plus side enclosure panels at each end of the coil	Improves aesthetics, protection against intrusion to the unit interior, coil and piping protection against impacts.	500-1150
Enclosure panels	23A	Side enclosure panels at each end of the coil	Improves aesthetics, coil and piping protection against impacts.	500-1150
Evaporator freeze protection	41A	Electric resistance heater on the evaporator and discharge valve	Evaporator freeze protection down to -20°C outside temperature	500-1150
Evap. and hydraulic mod. freeze protection	41B	Electric resistance heater on evaporator, discharge valve and hydronic module	Evaporator and hydronic module freeze protection down to -20°C outside temperature	Sizes 500/600 only
Master/slave operation	58	Unit equipped with supplementary water outlet temperature sensor kit to be field-installed allowing master/slave operation of two units connected in parallel	Optimised operation of two chillers connected in parallel with operating time equalisation	500-1150
Fuses on main disconnect switch	70D	Factory installed additional fuses, one per each phase, to protect main switch and associated cables from over-current flow (Note: frequency drives and electronic boards are protected as standard by dedicated fuses. Option 70D recommended when compliant protection devices on field not present)	No need for separate fuse box. Save time and money on site installation and avoid additional space requirement	600-1150 (standard on size 500)
Single power connection point	81	Unit power connection via one main supply connection (include option 70D)	Quick and easy installation	800-1150
Evaporator and Pump/s with aluminium jacket	88A	Evaporator and Pumps covered with an aluminium sheet for thermal insulation protection	Improved resistance to aggressive climate conditions	Sizes 500/600 only
Service valve set	92	Liquid line valve (evaporator inlet), compressor suction and discharge line valves and economiser line valve	Allow isolation of various refrigerant circuit components for simplified service and maintenance	500-1150
Compressor discharge valves	93A	Shut-off valve on the compressor discharge piping	Simplified maintenance	500-1150
Evaporator with one pass less	100C	Evaporator with one pass on the water side. Evaporator inlet and outlet on opposite sides.	Easy to install, depending on site. Reduced pressure drops	500-1150
21 bar evaporator	104	Reinforced evaporator for extension of the maximum water-side service pressure to 21 bar (standard 10 bar)	Covers applications with a high water column evaporator side (typically high buildings)	500-1150
Reversed evaporator water connections	107	Evaporator with reversed water inlet/outlet	Easy installation on sites with specific requirements	Sizes 500/600/950/1050/1150 only
HP single-pump hydronic module	116R	Complete hydronic module equipped with water filter, relief valve, one high pressure pump and drain valve. For more details, refer to the dedicated chapter (expansion tank not included)	Easy and fast installation (plug & play)	Sizes 500/600 only
HP dual-pump hydronic module	116S	Complete hydronic module equipped with water filter, relief valve, two high pressure pumps and drain valve. For more details, refer to the dedicated chapter (expansion tank not included)	Easy and fast installation (plug & play). Increased system reliability	Sizes 500/600 only
LP single-pump hydronic module	116T	Complete hydronic module equipped with water filter, relief valve, one low pressure pump and drain valve. For more details, refer to the dedicated chapter (expansion tank not included)	Easy and fast installation (plug & play)	Sizes 500/600 only
LP dual-pump hydronic module	116U	Complete hydronic module equipped with water filter, relief valve, two low pressure pumps and drain valve. For more details, refer to the dedicated chapter (expansion tank not included)	Easy and fast installation (plug & play). Increased system reliability	Sizes 500/600 only
J-Bus gateway	148B	Two-directional communication board complying with JBus protocol	Connects the unit by communication bus to a building management system	500-1150
Lon gateway	148D	Two-directional communication board complying with Lon Talk protocol	Connects the unit by communication bus to a building management system	500-1150
Bacnet over IP gateway	149	Two-directional high-speed communication using BACnet protocol over Ethernet network (IP)	Easy and high-speed connection by ethernet line to a building management system. Allows access to multiple unit parameters	500-1150
Energy Management Module	156	Control board with additional inputs/outputs. See Energy Management Module option chapter	Extended remote control capabilities (Set-point reset, ice storage end, demand limits, boiler on/off command...)	500-1150
Leak detection	159	0-10 V signal to report any refrigerant leakage in the unit directly on the controller (the leak detector itself must be supplied by the customer)	Immediate customer notification of refrigerant losses to the atmosphere, allowing timely corrective actions	500-1150
Dual relief valves installed w/ 3-way valve	194	Three-way valve upstream of the relief valves on the evaporator and the oil separator	Valve replacement and inspection facilitated without refrigerant loss. Comforms to European standard EN378/BGVD4	500-1150
Compliance with Russian regulations	199	GOST certification	Conformance with Russian regulations	500-1150
Insulation of the evap. in/out ref. lines	256	Thermal insulation of the evaporator entering/leaving refrigerant lines with flexible, anti-UV insulant	Prevents condensation on the evaporator entering/leaving refrigerant lines	500-1150
Low noise level	257	Sound insulation of main noise sources combined with fans speed management (includes option 279)	6 to 10 dB(A) quieter than standard unit (depending model and size). Refer to the physical data table for detailed values	500-1150

Options	No.	Description	Avantages	Utilisation
Enviro-Shield anti-corrosion protection	262	Coating by conversion process which modifies the surface of the aluminum producing a coating that is integral to the coil. Complete immersion in a bath to ensure 100% coverage. No heat transfer variation, tested 4000 hours salt spray per ASTM B117	Improved corrosion resistance, recommended for use in moderately corrosive environments	500-1150
Super Enviro-Shield anti-corrosion protection	263	Extremely durable and flexible epoxy polymer coating applied on micro channel heat exchangers by electro coating process, final UV protective topcoat. Minimal heat transfer variation, tested 6000 hours constant neutral salt spray per ASTM B117, superior impact resistance per ASTM D2794	Improved corrosion resistance, recommended for use in extremely corrosive environments	500-1150
Welded evaporator water connection kit	266	Victaulic piping connections with welded joints	Easy installation	500-1150
Compressor enclosure	279	Compressor sound enclosure	3 dB(A) quieter than standard unit	500-1150
Evaporator with aluminium jacket	281	Evaporator covered with an aluminium sheet for thermal insulation protection	Improved resistance to aggressive climate conditions	500-1150
EMC classification C2, as per EN 61800-3	282	Additional RFI filters on the unit power line	Reduces electromagnetic interferences. Increase the variable frequency drive (VFD) immunity level according to first environment (so called, residential environment) requirements and allow its compliancy with emissions level required in category C2	500-1150
230V electrical plug	284	230V AC power supply source provided with plug socket and transformer (180 VA, 0,8 Amps)	Permits connection of a laptop or an electrical device during unit commissioning or servicing	500-1150
Expansion tank	293	6 bar expansion tank in the hydraulic module (require option 116)	Protects closed hydronic circuit from excessive pressure	Sizes 500/600 only
Fast Capacity Recovery	QM295	New software algorithms to allow quick restart and fast loading while preserving unit-reliability	Full capacity recovery in less than 5 minutes after power failure. Matches requirements of typical critical missions applications	500-1150
Carrier Connect link (BSS regions only)	298	3G router board NOTE 1: require option 149 NOTE 2: when more than one machine is installed on site, only one of them shall be equipped with option 298 while all of them must be equipped with option 149 NOTE 3: If the Carrier® PlantCTRL™ is on site, option 298 shall be integrated in the Carrier® PlantCTRL™ while option 149 is still mandatory for each single unit.	Enabler for Carrier Connect service offer	500-1150
Variable Water Flow control	299	Hydronic control function package that permits control of the water flow rate based on different possible logics (at customer choice): constant ΔT , constant outlet pressure and "fixed-speed" control. For more details, refer to the dedicated chapter	When variable-speed pumps on the primary circuit, the VWF control modulates flow rate through the evaporator, minimising pump consumption while ensuring safe/optimised chiller operation	500-1150

11 - STANDARD MAINTENANCE

To ensure optimal efficiency and reliability of the units, we recommend establishing a maintenance contract with your local Carrier Service organisation. This contract will include regular inspections by Carrier Service specialists so that no serious damage can occur.

A Carrier Service maintenance contract is the best way to ensure the maximum operating life for your equipment and, through the expertise of Carrier technicians, provides the ideal way to manage your system cost effectively.

Air conditioning equipment must be maintained by professional technicians, whilst routine checks can be carried out locally by specialised technicians (refer to the standard EN 378-4).

All refrigerant charging, removal and draining operations must be carried out by a qualified technician and with the correct equipment for the unit. Any inappropriate handling can lead to uncontrolled fluid or pressure leaks.

WARNING: Before doing any work on the machine ensure that the power is switched off. If a refrigerant circuit is opened, it must be evacuated, recharged and tested for leaks. Before any operation on a refrigerant circuit, it is necessary to remove the complete refrigerant charge from the unit with a refrigerant charge recovery unit.

Simple preventive maintenance will allow you to get the best performance from your HVAC unit:

- Improved cooling performance.
- Reduced power consumption.
- Prevention of accidental component failure.
- Prevention of major time-consuming and costly interventions.
- Protection of the environment.

There are five maintenance levels for HVAC units, as defined by the AFNOR X60-010 standard.

NOTE: Any deviation or non-observation of these maintenance criteria will render the guarantee conditions for the HVAC unit null and void, and the manufacturer, Carrier France, will no longer be responsible.

11.1 - Level 1 maintenance

These simple procedures can be carried out by the user:

- Check for traces of oil (indicates a refrigerant leak).
- Check for missing / damaged protective devices, and improperly closed doors / covers.
- Check and record alarms (see 30XAV control manual)
- Check the clogging state of filters of aeration openings of the control box.

General visual inspection for any signs of deterioration.

11.2 - Level 2 maintenance

This level requires specific expertise in electrical, hydraulic and mechanical systems.

The frequency of this maintenance level may be monthly or annual, depending on the verification type.

In these cases, the following maintenance operations are recommended.

Carry out all level 1 operations, then:

- At least once a year, tighten the power circuit electrical connections (refer to the table 10.4 - Tightening torques).
- Check and tighten all control/command connections, if required (refer to the tightening torques table).
- Check the differential switches for correct operation every 6 months.
- Remove the dust and clean the interior of the control boxes, if required. Check filter cleanliness (if present).
- Check the presence and the condition of the electrical protection devices.
- Replace the fuses every 3 years or every 15000 hours (age-hardening).
- Replace the control box cooling fans every 5 years.
- Check the height of the anti-vibration mountings (located between the compressor rails and the unit chassis) after 5 years of operation, and then each year. When the total minimum height of the mountings is less than 25 mm replace the mountings
- Verify the hydronic connections.
- Purge the water circuit.
- Clean the water filter (see chapter 7- "Water Connections").
- Check the unit operating parameters and compare them with the previous inspection.
- Keep and maintain a maintenance sheet, attached to each HVAC unit.
- Check, inside the control box, the presence of voltage on the terminal connection of the cooler heaters and drives (activate the quick test mode to energise the heaters).

WARNING: For all these operations take adequate safety measures: use appropriate PPE (personal protective equipment), comply with all industry and local regulations, use common sense.

11.3 - Level 3 (or higher) maintenance

The maintenance at this level requires specific skills/approval/tools and expertise. Only the manufacturer, his representative or authorised agent are permitted to carry out this work. These maintenance operations concern for example:

- A major component replacement (compressor, evaporator)
- Any intervention on the refrigerant circuit (handling refrigerant)
- Changing of parameters set at the factory (application change)
- Removal or dismantling of the HVAC unit
- Any intervention due to a missed established maintenance operation
- Any intervention covered by the warranty.

To reduce waste, the refrigerant and the oil must be transferred in accordance with applicable regulations, using methods that limit refrigerant leaks and pressure drops and with materials that are suitable for the products.

Any leak detected must be repaired immediately.

The compressor oil that is recovered during maintenance contains refrigerant and must be treated accordingly.

The refrigerant under pressure must not be vented to atmosphere.

If a refrigerant circuit is opened, plug all openings if the operation takes up to one day, or charge the circuit with oxygen free nitrogen.

11.4 - Tightening torques for the main electrical connections

11.4.1 - Tightening torques for the main electrical connections

Component	Designation in the unit	Value (Nm)
Customer connections		
M10 screw-nut on phases	L1 /L2 /L3	30
Nut on ground terminals (M12)	PE	70
Compressor connections in the control box		
M10 screw-nut on disconnect switch downstream bars		30
M8 hexagon socket head cap		15-20
M10 hexagon socket head cap		25-30
Nut on ground terminal (M10)		5
Circuit breaker terminal screw 3RV2*1*	QF_ /QM_	0.8-1.2
Circuit breaker terminal screw 3RV2*2*	QF_ /QM_	2.0-2.5
Connections in fan controllers		
Screw in power supply terminals (line)		1.8
Screw in motor terminals		
Ground screw		3
Connections on compressor		
M12 nuts on phases		25
M12 screw on ground	EC_	25
Compressor variable speed drive		
6 M10 nuts	R/S/T U/V/W	19
2 M10 or M8 nuts	GND	19
9 M8 nuts (with fuses and busbars)	see picture	9.6

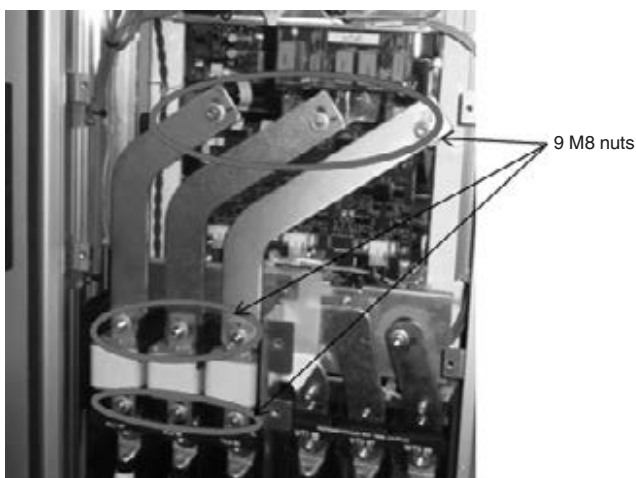

ATTENTION: The tightening of the connections at the compressor terminals requires special precautions. Please refer to the chapter below.

11.4.2 - Connection precautions for the compressor power terminals

These precautions must be applied during an intervention that requires the removal of the power conductors connected to the compressor supply terminals.

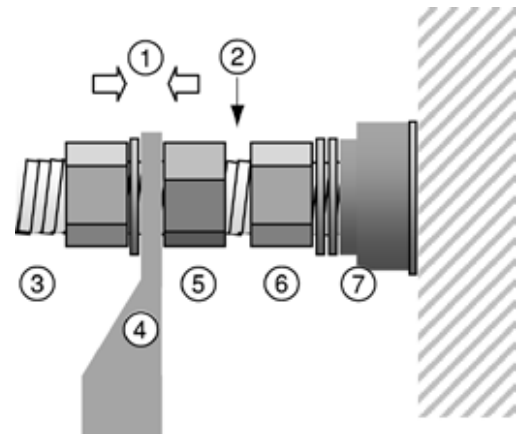

1. Application torque for tightening the clamp
2. Avoid contact between clamping nuts
3. Clamping nut husk
4. Pod flat
5. Against nut
6. Clamping nut terminal
7. Insulator

The tightening nut of terminal (6) supporting the isolator (7) must never be loosened, as it ensures terminal tightness and compressor leak tightness.

When securing the cable lug (4), apply the required torque between the clamping nut (3) and the backing nut (5). During this procedure a counter-torque must be applied to the backing nut (5). The backing nut (5) must not be in contact with the terminal securing nut (6).

11.5 - Tightening torques for the main bolts and screws

Screw Type	Utilisation	Value (Nm)
Tapping screws D = 4.8	Condensing module, housing, supports	4.2
H M8 screw	Condensing module, fan blade	18
M10 Taptite	Condensing module, frame, structure, control box fixing, compressor fixing, oil separators fixing	30
M6 Taptite	Mounting pipes, enclosure	7
M8 H screw	MCHE coil nut + studs	14
M6 H screw	Piping collar	10
M10 H screw	Oil separator fixing	7
M10 H screw	Compressor fixing (Nylstop nut)	23
M8 H screw	Filter drier cover	35
M12 H screw	Economiser port flange	40
M16 H screw	Oil separator flange nut +stud (TS/TT/TU)	190
M16 H screw	Suction flange TS/TT with gasket	190
M16 H screw	Heat exchanger water boxes	190
M20 / M16 H screw	Suction flange TU / TS O-ring	130
3/8 Nut ORFS	Oil line	65
3/8 Nut ORFS	Oil line	26
M12/M16 Hex nut	Victaulic collar 4" (M12 nut) and 5" (M16 nut) on suction line	65
M16 Hex nut	Victaulic collar 6" (M16 nut) on suction	110

11.6 - Condenser coil

We recommend, that coils are inspected regularly to check the degree of fouling. This depends on the environment where the unit is installed, and will be worse in urban and industrial installations and near trees that shed their leaves.

Recommendations for maintenance and cleaning of MCHE (microchannel) condenser coils

- Regular cleaning of the coil surface is essential for correct unit operation.
- Eliminating contamination and removal of harmful residue will increase the operating life of the coils and the unit.
- The maintenance and cleaning procedures below are part of the regular maintenance and will prolong the life of the coils.
- Specific recommendation in case of snow: For long term storage, regularly check that no snow has accumulated on the unit coils.

Products qualified as suitable for cleaning untreated MCHE coils are available from the Carrier spare parts network. After cleaning, rinsing of the coil is mandatory (see Carrier standard RW01--25). The use of any other cleaning product is strictly prohibited.

- Remove all foreign objects or fragments/debris attached to the coil surface or wedged between the chassis and the supports.
- Use a low-pressure dry air jet to remove all traces of dust from the coil.
- Wear the personal protection equipment, including safety glasses and or mask, waterproof clothes and safety gloves. It is recommended to wear clothing that covers the whole body.

WARNING: Never use pressurised water without a large diffuser. Concentrated and/or rotating water jets are strictly forbidden.

Never use a fluid with a temperature above 45°C to clean the air heat exchangers.

Correct and frequent cleaning (approximately every three months) will prevent 2/3 of the corrosion problems. Protect the control box, the motorized ball valve and the VFD during cleaning operations. Don't forget to remove protections after cleaning operations.

11.7 - Evaporator maintenance

Check that:

- The insulating foam is intact and securely in place.
- The cooler heaters are operating, secure and correctly positioned.
- The water-side connections are clean and show no sign of leakage.

11.8 - Compressor maintenance

11.8.1 - Oil separator

Check the correct operation of the heaters and check that they are properly attached to the oil separator shell.

11.8.2 - Integral oil filter change

As system cleanliness is critical to reliable system operation, there is a filter in the oil line at the oil separator outlet.

The oil filter is specified to provide a high level of filtration (5 µm) required for long bearing life.

The filter should be checked after the first 500 hours of operation, and every subsequent 2000 hours. The filter should

be replaced at any time when the pressure differential across the filter exceeds 200 kPa (2 bar).

The pressure drop across the filter can be determined by measuring the pressure at the filter service port and the oil pressure port. The difference in these two pressures will be the pressure drop across the filter, check valve, and solenoid valve. The pressure drop across the check valve and solenoid valve is approximately 40 kPa (0.4 bar), which should be subtracted from the two oil pressure measurements to give the oil filter pressure drop.

11.8.3 - Compressor rotation control

Correct compressor rotation is one of the most critical application considerations. Reverse rotation, even for a very short duration, damages the compressor.

The reverse rotation protection scheme must be able to determine the direction of rotation and stop the compressor within 300 ms. Reverse rotation is most likely to occur whenever the wiring to the compressor terminals is disturbed.

To minimise the opportunity for reverse rotation, the following procedure must be applied. Rewire the power cables to the compressor terminal pin as originally wired.

For replacement of the compressor, a low pressure switch is included with the compressor. This low pressure switch should be temporarily installed as a hard safety on the high pressure part of the compressor. The purpose of this switch is to protect the compressor against any wiring errors at the compressor terminal pin. The electrical contact of the switch would be wired in series with the high pressure switch. The switch will remain in place until the compressor has been started and direction of rotation has been verified; at this point, the switch will be removed.

The switch that has been selected for detecting reverse rotation is Carrier part number HK01CB001. This switch opens the contacts when the pressure falls below 7 kPa. The switch is a manual reset type that can be reset after the pressure has once again risen above 70 kPa. It is critical that the switch be a manual reset type to preclude the compressor from short cycling in the reverse direction.

11.9 - Variable frequency drive maintenance

CAUTION: Before any work on the VFD ensure that the circuit is isolated and there is no voltage present. Note that it may take 5 minutes for the circuit capacitors to fully discharge after isolating the circuit. Only appropriately qualified personnel are authorised to work on the VFD.

In case of any alarm or persistent problem related to the VFD, contact Carrier Service.

The VFDs fitted with 30XAV units do not require an insulation test, even if being replaced; they are systematically verified before delivery. Moreover, the filtering components installed in the VFD can falsify the measurement and may even be damaged. If there is a need to test the insulation of the unit components (fan motors and pumps, cables, etc.), the VFD must be disconnected at the power circuit.

12 - CHECKLIST TO BE MADE BY THE INSTALLER BEFORE CALLING CARRIER SERVICE COMMISSIONING UNIT

Preliminary information

Job name:

Location:

Installing contractor:

Distributor:

Equipment

Model 30XAV:.....

Compressors

<u>Circuit A</u>	<u>Circuit B</u>
Model #	Model #
S/N	S/N
Motor #	Motor #
Inverter compressor frequency	Fan Inverter frequency
Model # (circuit A/B) :	Model # (circuit A/B) :
Serial number (circuit A/B) :	Serial number (circuit A/B) :

Evaporator

Model :

S/N

Condensing module

Model # :

Unit options and additional accessories
.....
.....

Is there any shipping damage

If so, where?.....

Will this damage prevent unit start-up?.....

- Unit is level in its installation
- Power supply agrees with the unit name plate
- Electrical circuit wiring has been sized and installed properly
- Unit ground wire has been connected
- Electrical circuit protection has been sized and installed properly
- All terminals are tight
- All cables and thermistors have been inspected for crossed wires
- Chilled water pipes are properly connected
- All plug assemblies are tight
- The chilled water pump operating with the correct rotation. Check the phase sequence of the electrical connection. In the case of a unit with hydronic module, use the pump test function (refer to manual control 30XAV for a more detailed explanation).
- The machine is reset once power off the pump test performed.
- Circulating ice water in the hydraulic circuit for at least 2 hours, then remove, clean and replace the strainer. The machine is reset once power off the pump test performed.
- Piping water inlet to the evaporator includes a strainer with a mesh size of 1.2 mm (20 mesh)



Unit start-up

- a. Oil heaters have been energised for at least 24 hours (30XAV)
- b. All discharge and liquid valves are open
- c. All suction valves are open, if equipped
- d. All oil line valves and economiser valves (if equipped) are open
- e. The contractor
- f. Checks have been carried out for any possible leaks. The unit has been leak checked (including fittings)
 - f1. On the whole unit
 - f2. At all connections
 Locate and report any refrigerant leaks

g. Check voltage imbalance:

	AB	AC	BC
Average voltage =	V
Maximum deviation =	V
Voltage imbalance =	%

- h. Voltage imbalance is less than 2%

WARNING: Operation of the chiller with an improper supply voltage or excessive phase imbalance constitutes abuse which will invalidate the Carrier warranty. If the phase imbalance exceeds 2% for voltage, or 10% for current, immediately contact your local electricity supply at once and ensure that the chiller is not switched on until corrective measures have been taken .

Check evaporator water loop

- Water loop volume = litres
- Calculated volume = litres
- 3.25 liters / nominal kW capacity for air conditioning
- 6.5 liters / nominal kW capacity for cooling in industrial processes
- Proper loop volume established
- Proper loop corrosion inhibitor included..... litres of.....
- Proper loop freeze protection included (if required)..... litres of.....
- Piping installation is equipped with heating cables, if exposed to temperatures below 0 ° C.
- Return water piping is equipped with a screen filter with a mesh size of 1.2 mm

Check pressure drop across the cooler

- Entering cooler =.....kPa
- Leaving cooler=.....kPa
- Pressure drop (entering - leaving) =.....kPa

WARNING: Plot cooler pressure drop on performance data chart (in product data literature) to determine total litres per second (l/s) and find unit's minimum flow rate.

- Total =.....l/s
- Nominal kW =.....l/s
- The total is above the minimum flow unit
- The total corresponds to specifications.....l/s

WARNING: Once the unit is switched on, check for any alarms (refer to the manual IOM Control 30XAV to view the Alarm menu).

Report all alarms :

Special Remarks :

To Start the chiller

WARNING: *Ensure that all service valves are open, and the pump is running before attempting to start this machine. Once all checks have been made, try to start the unit.*

The unit starts and runs properly.

Temperatures and pressures

WARNING: *Once the machine has been operating for a while and the temperatures and pressures have stabilised, record the following:*

- Evaporator entering water
- Evaporator leaving water
- Ambient temperature
- Circuit A suction pressure
- Circuit B suction pressure.....
- Circuit A discharge pressure.....
- Circuit B discharge pressure.....
- Circuit A suction temperature
- Circuit B suction temperature.....
- Circuit A discharge temperature.....
- Circuit B discharge temperature.....
- Circuit A liquid line temperature.....
- Circuit B liquid line temperature.....
- Value of the sub cooling circuit A.....
- Value of the sub cooling circuit B



Order No: 13552, 12.2016 - Supersedes order No: 13552, 07.2015.
Manufacturer reserves the right to change any product specifications without notice.



Quality and Environment
Management Systems
Approval

Manufacturer: Carrier SCS, Montluel, France.
Printed in the European Union.