



30RB/30RQ

Pro-Dialog *PLUS* Control

PRO-DIALOG

AQUASNAP™

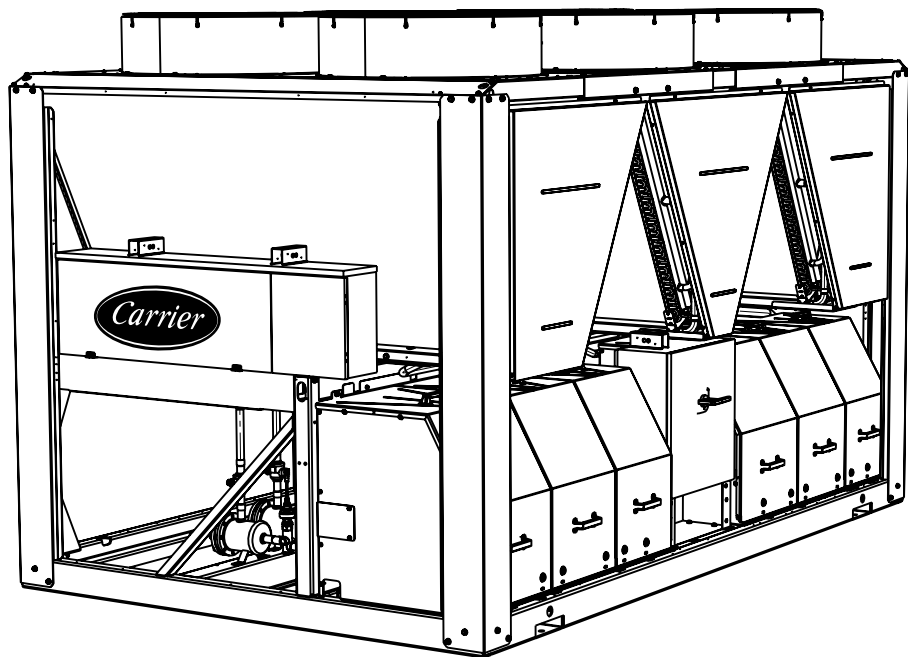

Operation and maintenance instructions







Quality and Environment
Management Systems
Approval

CONTENTS

1 - SAFETY CONSIDERATIONS	3
1.1 - General	3
1.2 - Avoid electrocution	3
2 - GENERAL DESCRIPTION.....	3
2.1 - General	3
2.2 - Abbreviations used.....	3
3 - HARDWARE DESCRIPTION	4
3.1 - General	4
3.2 - Electrical supply to boards.....	4
3.3 - Light emitting diodes on boards.....	4
3.4 - The sensors	4
3.5 - The controls.....	5
3.6 - Connections at the user's terminal block	5
4 - SETTING UP PRO-DIALOG PLUS CONTROL.....	7
4.1 - User interface general features.....	7
4.2 - Unit start/stop control.....	8
4.3 - Menus	9
5 - PRO-DIALOG PLUS CONTROL OPERATION.....	28
5.1 - Start/stop control	28
5.2 - Heating/cooling/standby operation.....	28
5.3 - Evaporator water pump control.....	29
5.4 - Control interlock contact	29
5.5 - Evaporator antifreeze protection.....	29
5.6 - Control point.....	29
5.7 - Demand limit	31
5.8 - Night mode.....	31
5.9 - Capacity control	31
5.10 - Head pressure control.....	31
5.11 - Defrost function	31
5.12 - Additional electric heater stage control	31
5.13 - Control of a boiler.....	31
5.14 - Master/slave assembly	31
5.15 - Optional heat reclaim module	32
5.16 - Free-cooling option	32
6 - DIAGNOSTICS - TROUBLESHOOTING	33
6.1 - General	33
6.2 - Displaying alarms.....	33
6.3 - Resetting alarms.....	33
6.4 - Alarm codes	34

GENERAL LEGEND

Each of the following drawings is replaced in the whole document by the corresponding explanation:

-  Start/stop button
-  Return key
-  Down arrow
-  Up arrow
- Δ DELTA T. Example: temperature difference between entering and leaving heat exchanger temperatures
-  Means character is flashing

The cover graphics are solely for illustration and forms no part of any offer for sale or any sale contract. The manufacturer reserves the right to change the design at any time without notice.

1 - SAFETY CONSIDERATIONS

1.1 - General

Installation, start-up and servicing of equipment can be hazardous if certain factors particular to the installation are not considered: operating pressures, presence of electrical components and voltages and the installation site (elevated plinths and built-up structures). Only properly qualified installation engineers and highly qualified installers and technicians, fully trained for the product, are authorised to install and start-up the equipment safely. During all servicing operations all instructions and recommendations which appear in the installation and service instructions for the product, as well as on tags and labels fixed to the equipment and components and accompanying parts supplied separately, must be read, understood and followed.

- Apply all standard safety codes and practices.
- Wear safety glasses and gloves.
- Use the proper tools to move heavy objects. Move units carefully and set them down gently.

1.2 - Avoid electrocution

Only personnel qualified in accordance with IEC (International Electrotechnical Commission) recommendations may be permitted access to electrical components. It is particularly recommended that all sources of electricity to the unit be shut off before any work is begun. Shut off the main power supply at the main circuit breaker or isolator.

IMPORTANT: *This equipment uses and emits electromagnetic signals. Tests have shown that the equipment conforms to all applicable codes with respect to electromagnetic compatibility.*

RISK OF ELECTROCUTION: *Even when the main circuit breaker or isolator is switched off, certain circuits may still be energised, since they may be connected to a separate power source.*

RISK OF BURNS: *Electrical currents cause components to get hot either temporarily or permanently. Handle power cable, electrical cables and conduits, terminal box covers and motor frames with great care.*

Fan start-up:

ATTENTION: *In accordance with the operating conditions the fans can be cleaned periodically. A fan can start at any time, even if the unit has been shut down.*

2 - GENERAL DESCRIPTION

2.1 - General

Pro-Dialog is a system for controlling single-, dual- or triple-circuit 30RB air-cooled liquid chillers or 30RQ air-to-water heat pumps. Pro-Dialog controls compressor start-up needed to maintain the desired heat exchanger entering or leaving water temperature. In cooling mode it controls the operation of the fans to maintain the correct condensing pressure in each circuit. For heat pump units it controls and optimises the defrost cycles of each circuit in order to minimize the heating capacity reduction. Safety devices are constantly monitored by Pro-Dialog to ensure their safe operation. Pro-Dialog also gives access to a Quick Test program covering all inputs and outputs.

All Pro-Dialog Plus controls can work in accordance with three independent modes:

- Local mode: the machine is controlled by commands from the user interface.
- Remote mode: the machine is controlled by remote contacts (voltage-free contacts).
- CCN mode: the machine is controlled by commands from the Carrier Comfort Network (CCN). In this case, a data communication cable is used to connect the unit to the CCN communication bus.

The operating mode must be chosen with the Start/Stop button described in section 4.2.1. When the Pro-Dialog Plus system operates autonomously (Local or Remote mode) it retains all of its own control capabilities but does not offer any of the features of the CCN network.

2.2 - Abbreviations used

In this manual, the refrigeration circuits are called circuit A, circuit B and circuit C. The compressors in circuit A are labelled A1, A2, A3 and A4. Those in circuit B are B1, B2, B3 and B4 and those in circuit C are C1, C2, C3 and C4.

The following abbreviations are used frequently:

CCN : Carrier Comfort Network

CCn : Operating type: CCN

LED : Light Emitting Diode

LEN : Sensor Bus (internal communication bus linking the basic board to the slave boards)

LOFF: Operating type: Local Off

L-On : Operating type: Local On mode

L-Sc : Operating type: Local On following a time schedule

MASt: Operating type: master unit (master/slave assembly)

rEM : Operating type: by remote contacts

SCT : Saturated Condensing Temperature

SST : Saturated Suction Temperature

EXV : Electronic Expansion Valve

3 - HARDWARE DESCRIPTION

3.1 - General

Figure 1 - control board

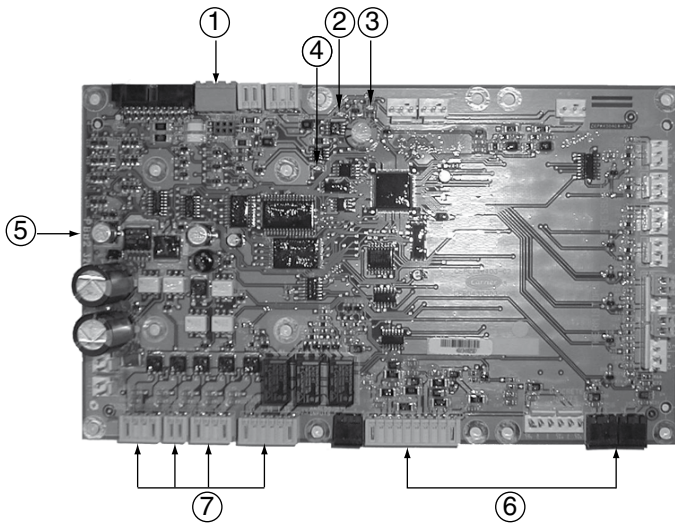

Legend

- 1 CCN connector
- 2 Red LED, status of the board
- 3 Green LED, communication bus LEN
- 4 Orange LED, communication bus CCN
- 5 PD5 basic board
- 6 Remote customer control connection contacts
- 7 Master board customer connection relay outputs

The control system consists of a PD5-BASE board, SPM boards for compressor control, PD-AUX boards for fan control, and an NRCP2-BASE board for units equipped with energy management option or heat reclaim option. All boards communicate via an internal LEN bus. The PD5-BASE boards continuously manage the information received from the various pressure and temperature probes, and incorporates the program that controls the unit.

The user interface consists of two display blocks with up to 26 LEDs and 16 buttons (according to unit type). It is connected to the main basic board and gives access to a full array of control parameters.

3.2 - Electrical supply to boards

All boards are supplied from a common 24 V a.c. supply referred to earth.

CAUTION: Maintain the correct polarity when connecting the power supply to the boards, otherwise the boards may be damaged.

In the event of a power supply interrupt, the unit restarts automatically without the need for an external command. However, any faults active when the supply is interrupted are saved and may in certain cases prevent a circuit or unit from restarting.

3.3 - Light emitting diodes on boards

All boards continuously check and indicate the proper operation of their electronic circuits. A light emitting diode (LED) lights on each board when it is operating properly.

- The red LED flashing for a 2 second period on the NRCP-BASE board indicates correct operation. A different rate indicates a board or a software failure.
- The green LED flashes continuously on all boards to show that the board is communicating correctly over its internal bus. If the LED is not flashing, this indicates a LEN bus wiring problem.
- The orange LED of the master board flashes during any communication via the CCN bus.

3.4 - The sensors

Pressure sensors

Two types of electronic sensors are used to measure the suction and discharge pressure in each circuit.

Thermistors

The evaporator water sensors are installed in the entering and leaving side. The outdoor temperature sensor is mounted below the control box. An optional water system temperature sensor can be used for master/slave assembly control (in the case of leaving water control).

In heat pump units a sensor placed on an air heat exchanger pipe ensures defrost operation.

3.5 - The controls

Evaporator pumps

The controller can regulate one or two evaporator pumps and takes care of automatic change-over between pumps.

Evaporator heater

It protects the evaporator (and the pipe heater for units without pump) against freezing if the unit is off.

Boiler

This relay output authorises start/stop of a boiler.

3.6 - Connections at the user's terminal block

3.6.1 - General description

The contacts below are available at the user's terminal block on the PD5-BASE board (see figure 1). Some of them can only be used if the unit operates in remote operating type (rEM). The following table summarises the connections at the user's terminal block.

Cooling units				
Description	Connector/ channel	Terminal	Board	Remarks
Evaporator pump 1 control	J2A / CH19		PD5-BASE	The control can regulate one or two evaporator pumps, and automatically change over between the two pumps.
Evaporator pump 2 control	J2A / CH20		PD5-BASE	The control can regulate one or two evaporator pumps, and automatically change over between the two pumps.
Evaporator heater control	J2B / CH21		PD5-BASE	This (and the pipe heater for units without pumps) protects the evaporator against frost.
Alarm relay output	J3 / CH24		PD5-BASE	Indicates alarms.
Alert relay output	J3 / CH25		PD5-BASE	Indicates alerts.
Operation or ready-to-start relay output	J3 / CH26		PD5-BASE	Indicates if the unit is ready to start or operates.
Contact 1: Start/stop	J4 / CH11	32-33	PD5-BASE	This contact is used for unit start/stop. It is only taken into account if the unit is under remote operation control (rEM).
Contact 2: Setpoint selection	J4 / CH12	65-66	PD5-BASE	This contact is only taken into account if the unit is under remote operation control (rEM).
Contact 3: Demand limit selection 1	J4 / CH13	63-64	PD5-BASE	See the description of these contacts in sections 3.6.5 and 3.6.6.
Contact 3 bis: Demand limit selection 2	CH9		NRCP2-BASE	This contact is only present if the energy management option is used.
User safety loop input	J4 / CH15a	34-35	PD5-BASE	This contact is mounted in series with the water flow control contact. It can be used for any customer safety loop that requires that the unit is stopped, if it is open. If it is unused this contact must be bridged.
Contact 4: Heat reclaim selection	J4 / CH14		PD5-BASE	This contact is used to select the heat reclaim mode. This contact is only used, if the heat reclaim option is used (not compatible with the free cooling option).
Contact 4: Free cooling prevention	J4 / CH14		PD5-BASE	If this contact is closed, it is used to prevent operation of the free cooling mode. It is only taken into account, if the unit is under remote operation control (rEM). This contact is only used if the free cooling option is used (incompatible with the heat reclaim option).
Contact 5: Pump operation status	J5C / CH18		PD5-BASE	If this contact is open, the pump is controlled and an alarm has tripped.
Connection to CCN	J12		PD5-BASE	An RS-485 bus is used for connection to the CCN. - Pin 1: signal + - Pin 2: ground - Pin 3: signal -
Critical alarm relay output	J2C / CH23		PD5-BASE	Output allows disconnecting the general unit power supply, if a contactor is stuck and there is an increased risk of the unit being damaged.

Heat pump units

Description	Connector/ channel	Terminal	Board	Remarks
Evaporator pump 1 control	J2A / CH19		PD5-BASE	The control can regulate one or two evaporator pumps, and automatically change over between the two pumps.
Evaporator pump 2 control	J2A / CH20		PD5-BASE	The control can regulate one or two evaporator pumps, and automatically change over between the two pumps.
Evaporator heater control	J2B / CH21		PD5-BASE	This (and the pipe heater for units without pumps) protects the evaporator against frost.
4-way valve A control	J2C / CH22		PD5-BASE	The control regulates the 4-way valve during heat/cool changeover or during defrost cycles.
4-way valve B control	J2C / CH23		PD5-BASE	The control regulates the 4-way valve during heat/cool changeover or during defrost cycles.
Alarm relay output	J3 / CH24		PD5-BASE	Indicates alarms.
Alert relay output	J3 / CH25		PD5-BASE	Indicates alerts.
Operation or ready-to-start relay output	J3 / CH26		PD5-BASE	Indicates if the unit is ready to start or operates.
Contact 1: Start/stop	J4 / CH11	32-33	PD5-BASE	This contact is used for unit start/stop. It is only taken into account if the unit is under remote operation control (rEM).
Contact 2: Setpoint selection	J4 / CH12	65-66	PD5-BASE	This contact is only taken into account if the unit is under remote operation control (rEM).
Contact 3: Demand limit selection 1	J4 / CH13	63-64	PD5-BASE	See the description of these contacts in sections 3.6.5 and 3.6.6.
Contact 3 bis: Demand limit selection 2	CH9		NRCP2-BASE	This contact is only present if the energy management option is used.
User safety loop input	J4 / CH15a	34-35	PD5-BASE	This contact is mounted in series with the water flow control contact. It can be used for any customer safety loop that requires that the unit is stopped, if it is open. If it is unused this contact must be bridged.
Contact 4: Heating/cooling selection	J5B / CH17		PD5-BASE	This contact is used for heating/cooling mode selection. It is only taken into account if the unit is under remote operation control (rEM).
Contact 5: Pump operation status	J5C / CH18		PD5-BASE	If this contact is open, the pump is controlled and an alarm has tripped.
Connection to CCN	J12		PD5-BASE	An RS-485 bus is used for connection to the CCN. - Pin 1: signal + - Pin 2: ground - Pin 3: signal -
Critical alarm relay output	J2C / CH22		NRCP2-BASE	Output allows disconnecting the general unit power supply, if a contactor is stuck and there is an increased risk of the unit being damaged (available if the energy management option is used).

3.6.2 - Volt-free contact on/off/cooling/heating without multiplexing

If the automatic heating/cooling changeover function is not selected (see section 5.2) and if the user configuration allows this (heat pump and Pro-Dialog interface selection) the operation of contacts 1 and 4 is as follows:

	OFF	ON cooling	ON heating
Contact 1	Open	Closed	Closed
Contact 4	-	Open	Closed

Contact status not significant

3.6.3 - Volt-free contact on/off/cooling/heating with multiplexing

If the automatic heating/cooling changeover function is selected (see section 5.2) and if the user configuration allows this (heat pump and Pro-Dialog interface selection) the operation of contacts 1 and 4 is multiplexed:

	OFF	ON cooling	ON heating	ON auto
Contact 1	Open	Closed	Closed	Open
Contact 4	Open	Open	Closed	Closed

NOTE: The automatic changeover function (ON auto) selects the cooling or heating mode based on the outdoor temperature (see section 5.2).

3.6.4 - Volt-free setpoint selection

This volt-free contact permits changing the setpoint. The setpoints can be modified in the setpoint menu.

	Cooling		Heating			
	CSP 1	CSP2	Auto	HSP1	HSP2	Auto
Contact 2	Open	Closed	-	Open	Closed	-

3.6.5 - Volt-free demand limit contact with energy management option

For units with the energy management option the demand limit contact 3 is located on the PD5-BASE board and contact 3 bis is on the NRP2-BASE board. Demand limit is now multiplexed.

	Capacity			
	100%	limit 1	limit 2	limit 3
Contact 3	Open	Closed	Open	Closed
Contact 3 bis	Open	Open	Closed	Closed

3.6.6 - Volt-free demand limit contact without energy management option

For units without energy management option, contact 3 is located on the PD5-BASE board.

	Capacity	
	100%	limit 1
Contact 3	Open	Closed

4 - SETTING UP PRO-DIALOG PLUS CONTROL

4.1 - User interface general features

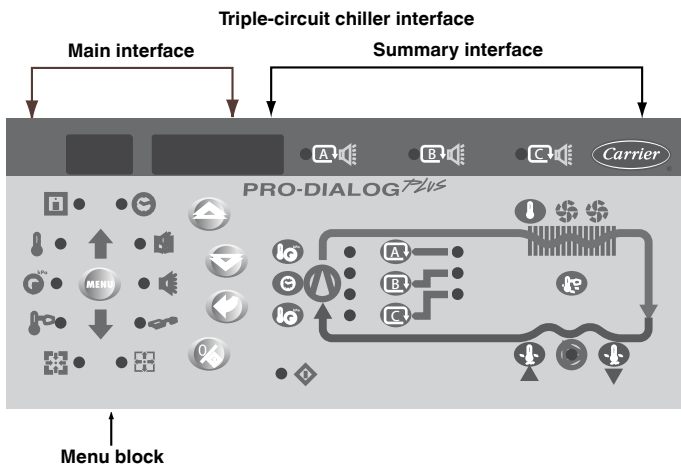
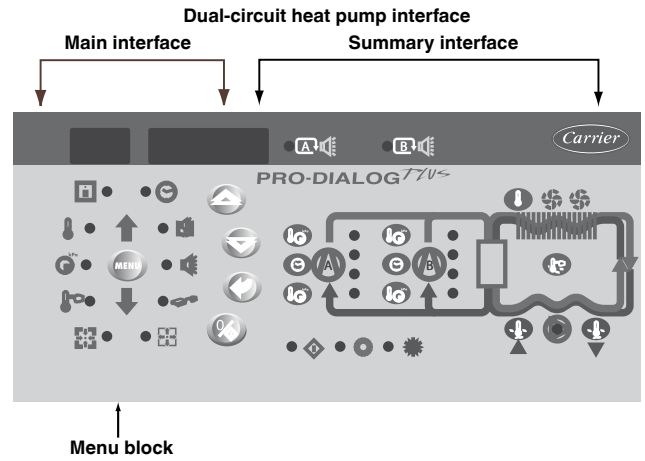
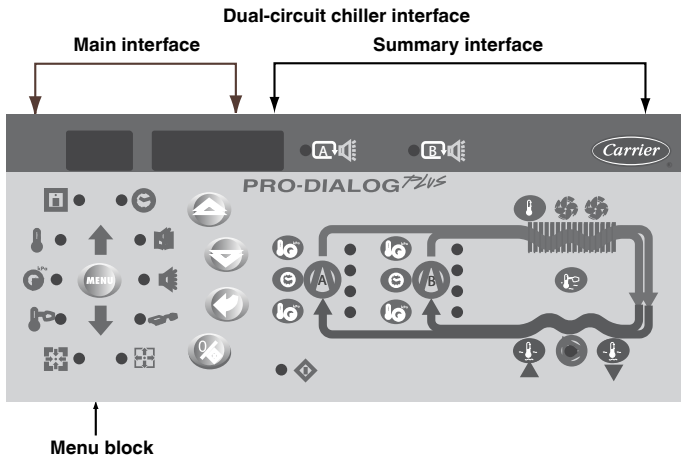

The local interface enables a number of operating parameters to be displayed and modified. The interface consists of two distinct parts: the main interface (left hand section) and the summary interface (right hand section).

Main interface

It gives access to all Pro-Dialog Plus data and operating functions. It consists of:

- A two-digit display showing the number of the item selected.
- A four-digit display showing the contents of the item selected.
- LEDs and buttons for unit start/stop, menu selection, menu item selection and value adjustment.

Main interface









Button	Name	Description
	Menu	Permits the selection of a main menu. Each main menu is represented by an icon. The icon is lit if active.
	Up arrow	Permits scrolling through the menu items (in the two-digit display). If the modification mode is active this button authorises increase of the value of any parameter.
	Down arrow	Permits scrolling through the menu items (in the two-digit display). If the modification mode is active this button authorises decrease of the value of any parameter.
	Enter	Gives access to the modification mode, validates a modification or displays expanded item description.
	Start/stop	Authorises start or stop of the chiller in local mode or modification of its operating type.

Main interface menu LEDs





LED	Name	Description
	INFORMATION menu	Displays the general operating parameters for the unit.
	TEMPERATURES menu	Displays the unit operating temperatures.
	kPa PRESSURES menu	Displays the unit operating pressures.
	SETPOINTS menu	Displays the unit setpoints and enables them to be modified.
	INPUTS menu	Displays the status of the unit digital and analogue inputs.
	OUTPUTS/TESTS menu	Displays the status of the unit outputs and enables them to be tested.
	CONFIGURATIONS menu	Displays the unit configuration and enables it to be modified.
	ALARMS menu	Displays active alarms.
	ALARMS HISTORY menu	Displays the history of the alarms.
	OPERATING LOG menu	Displays the operating times and number of starts for the unit and the compressors.

The summary interface (right hand section) includes a mimic diagram of the unit, together with push-buttons and LEDs. It gives quick access to the main operating parameters of the unit.

Summary interface LEDs









LED	Indication when lit
	Green LED: The unit is authorised to start or is already running
A 	Red LED: - Lit: circuit A or unit shut down by alarm - Flashing: circuit A or unit running with alarm present
B 	Red LED: - Lit: circuit B or unit shut down by alarm - Flashing: circuit B or unit running with alarm present
C 	Red LED: - Lit: circuit C or unit shut down by alarm - Flashing: circuit C or unit running with alarm present
	Green LED: The evaporator pump is running.
	Yellow LEDs: From top to bottom - start/stop status of compressor A1, A2, A3 and A4 or B1, B2, B3 and B4 or C1, C2, C3 and C4. Flashing LED indicates that the circuit is in the protection or defrost mode (A, B or C).
	Green LED: The unit operates in heating mode.
	Green LED: The unit operates in cooling mode.

Summary interface push buttons (dual-circuit)

Button	Display
	Blue button: evaporator leaving or entering water temperature in °C Gray button: outdoor air temperature in °C
	Control point (setpoint + reset) in °C
 (1)	Press 1: circuit A/B discharge pressure in kPa Press 2: circuit A/B saturated condensing temperature in °C
 (1)	Press 1: circuit A/B suction pressure in kPa Press 2: circuit A/B saturated suction temperature in °C
 (1)	Press 1: compressor A1/B1 operating hours in h/10 or h/100 Press 2: compressor A2/B2 operating hours in h/10 or h/100 Press 3: compressor A3/B3 operating hours in h/10 or h/100 Press 4: compressor A4/B4 operating hours in h/10 or h/100

(1) There is a separate button for each of the two circuits.

Summary interface push buttons (triple-circuit)

Button	Display
	Blue button: evaporator leaving or entering water temperature in °C Gray button: outdoor air temperature in °C
	Control point (setpoint + reset) in °C
 (1)	Press 1: circuit A/B/C discharge pressure in kPa Press 2: circuit A/B/C saturated condensing temperature in °C
 (1)	Press 1: circuit A/B/C suction pressure in kPa Press 2: circuit A/B/C saturated suction temperature in °C
 (1)	Press 1: compressor A1/B1/C1 operating hours in h/10 or h/100 Press 2: compressor A2/B2/C2 operating hours in h/10 or h/100 Press 3: compressor A3/B3/C3 operating hours in h/10 or h/100 Press 4: compressor A4/B4/C4 operating hours in h/10 or h/100
	Press 1: Selects circuit A to display information (only on triple-circuit units)
	Press 1: Selects circuit B to display information (only on triple-circuit units)
	Press 1: Selects circuit C to display information (only on triple-circuit units)

(1) There is a common button for the three circuits; for circuit selection press one of the three last buttons described above.

4.2 - Unit start/stop control

4.2.1 - Description

The unit start/stop can be controlled by one of the following methods:

- Locally on the actual unit (Local control type)
- By remote control with the aid of user contacts (remote control type)
- By CCN control with the aid of the CCN (CCN control type)

The main interface includes a Start/Stop button which can be used to stop or start the unit in the local operating type or to select the remote or CCN operating type.

The available operating types are described in the following table.

The following operating types can be selected using the Start/Stop button:

Operating types	
4-digit display	Description
LOFF	Local Off. The unit is halted in local mode.
L-On	Local On. The unit is in local control mode and is authorised to start.
L-Sc*	Local On - timer control. The unit is in local control mode. It is authorised to start if the period is occupied. If the timer program for unit operation is unoccupied, the unit remains shut down until the period becomes occupied.
CCN	CCN. The unit is controlled by CCN commands.
rEM	Remote. The unit is controlled by remote control contacts.
MAST*	Master Unit. The unit runs as a master in a two unit lead/lag arrangement. This is displayed if the unit is configured for master/slave control.

* Displayed if the configuration requires it. Section 5.1 gives a more detailed description of the commands to start/stop the unit, analysed by operating type.

4.2.2 - Stopping the unit in local mode



The unit can be stopped in local mode at any time by pressing the Start/Stop button.

To stop the unit			
Button	Action	2-digit display	4-digit display
	Press the Start/Stop button for less than 4 seconds (one short press is enough).	C	LOFF
	If the button is released, the unit stops without the need for further action.	t	LOFF





4.2.3 - Starting unit and selecting an operating type

The unit can be started in local mode, or unit operating type can be changed at any time using the Start/Stop button. In the example that follows, the unit is stopped (LOFF) and the user wants to start the unit in local mode.

Start-up with the previously used operating type when the unit is stopped in local mode (loff)

Button	Action	2-digit display	4-digit display
	The unit is in local stop mode. The previously used operating type is local on (L-ON)		LOFF
	Press the Start/Stop button for 4 seconds (one short press-down is sufficient). L-ON illuminates immediately. "C" flashes in the 2-digit display to show that the controller is awaiting confirmation.		L-On
	Press the Enter button to confirm the operating type. "t" is displayed in the 2-digit display to indicate the operating type selected. If the Enter button is not pressed soon enough, the controller will cancel the change and remain in the stop mode.		L-On

Changing the operating type

Button	Action	2-digit display	4-digit display
	Continually press the operating type selection button for more than 4 seconds.	C	LOFF
	Hold down the Start/Stop button. The available operating types are displayed one by one until the button is released.		L-On L-Sc ↑ rEM ↓
	Release the Start/Stop button if the operating type you want is displayed (in this example L-On). "C" flashes in the 2-digit display to show that the controller is awaiting confirmation.		
	Press the Enter button to confirm the operating type selected (in this example: L-On). "t" is displayed in the 2-digit display to indicate the operating type selected. If the Enter button is not pressed soon enough, the controller will cancel the change and continue to use the previous operating type.		L-On

4.3 - Menus

4.3.1 - Selecting a menu







The MENU button authorises you to select a menu from the 10 main menus that are available. Each time you press this button one of the 10 LEDs lights up in turn alongside each of the icons representing a main menu. The active menu is the one against which the LED is lit. If a menu is empty then its LED is not lit. To scroll quickly through the menus, hold the MENU button down.

4.3.2 - Selecting a menu item

The up and down Arrow buttons let you scroll through the menu items. Menu item numbers are displayed in the two-digit display. The item number increases or decreases every time you press the up or down Arrow button. The menu items that are not in use or incompatible with the configuration are not displayed. The value or status associated with the active item is displayed in the four-digit display. To scroll quickly through the items, hold the up or down Arrow button down.

The following example shows how to access item 3 in the Pressures menu.

Selecting a menu item

Operation	Press button	Menu LED	Item number 2-digit display
Press the MENU button until the LED marked PRESSURE lights.	 ⋮ 	 kPa	0 0
Press one of the Arrow buttons until the two-digit display shows 3 (item number 3).	  	 kPa	1 2 3

4.3.3 - Modifying the value of a parameter/access to a sub-menu

Press the Enter button for more than 2 seconds to enter the modification mode or to select a sub-menu. This lets you correct the value of an item or select a sub-menu with the aid of the up and down Arrow buttons (if you are authorised to overwrite the item concerned). When modification mode is activated, the LED for the main menu to which the item belongs as well as the 2-digit display flash in the menu block. Once the required value is obtained, press the Enter button again to validate the change or to access the sub-menu. The LED for the menu to which the item and the 2-digit display belong then stops flashing, indicating that modification mode no longer applies.



















In modification mode, the value to be modified increases or decreases in steps of 0.1 every time you press the Arrow buttons. Holding one of these buttons down increases the rate of increase or decrease.

NOTE: The access to a sub-menu may require entering a password. This is automatically requested. See section 4.3.11.2.

The following example shows how to modify the value of item 1 in the Setpoint menu.

4.3.4 - Expand display

Pressing the Enter button causes a 23 character text expansion to be scrolled across the four-digit display. All user menus provide an expansion of the current displayed parameters. If the expansion is complete the four-digit display reverts to item value. This function can be inhibited through the User Configuration menu.

Modifying the value of a parameter	Press button	Menu LED	Item number	2-digit display	Item 4-digit display
Operation value					
Hold on the MENU button until the LED for SETPOINT lights.			0		
			0		
Press one of the Arrow buttons until the two-digit display shows 1 (item number 1- cooling setpoint 2). The value for setpoint 2 is displayed in the four-digit display (6.0°C in this example).			1		6.0
			1		
Press the Enter button for more than 2 seconds to enable the value associated with item 1 to be modified. The Setpoint menu LED and the two-digit display flash indicating that modification mode is active.			1		6.0
Keep pressing the Down Arrow button until the value 5.7 is displayed in the four-digit display. The Setpoint menu LED and the two-digit display keep flashing.			1		5.9
			1		5.8
			1		5.7
Press the Enter button again to validate the change. The new setpoint is 5.7°C. The Setpoint menu LED and the two-digit display stop flashing, indicating that modification mode no longer applies.			1		5.7

Menu structure

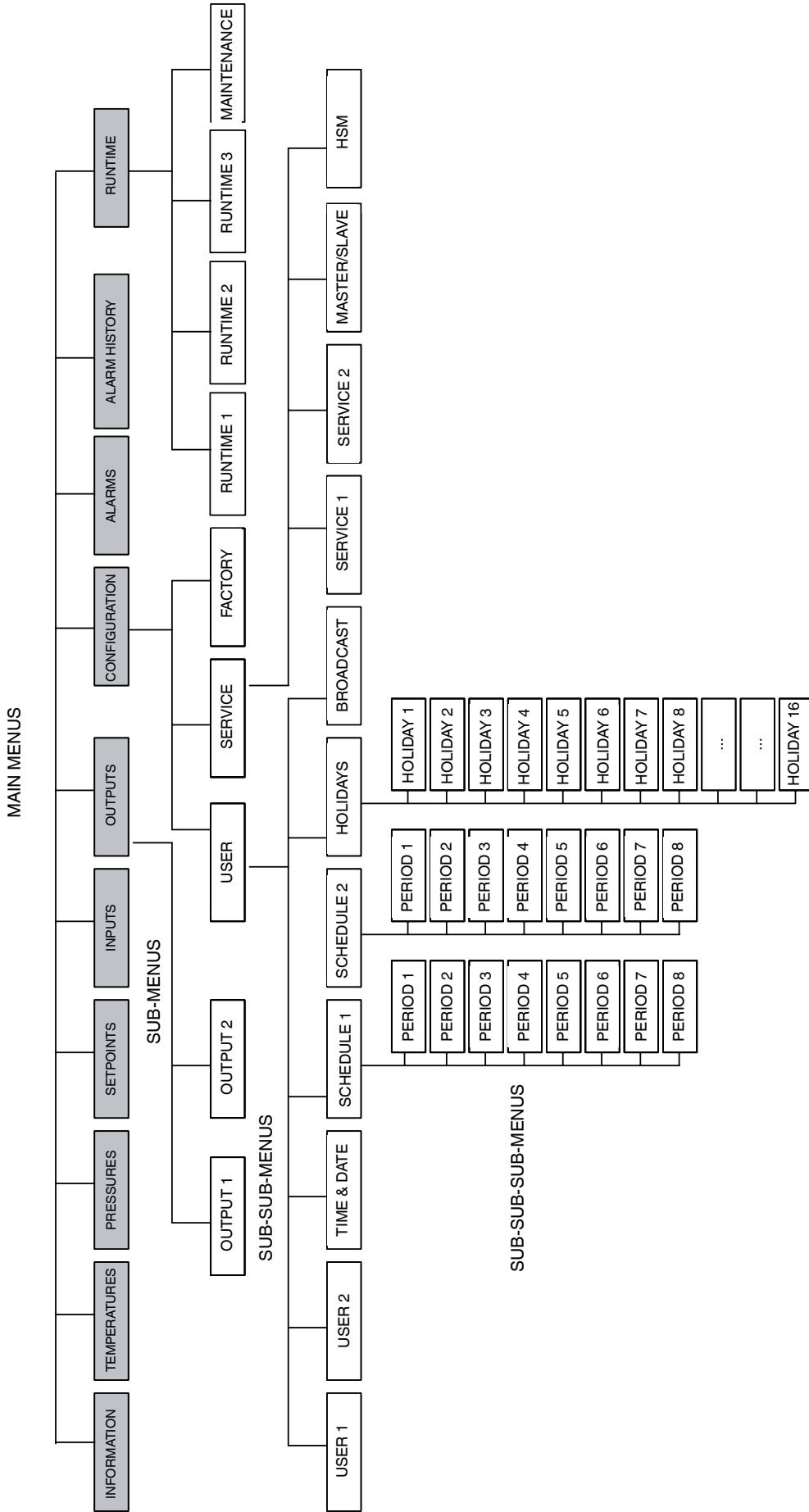

Menu tree structure

ITEM	STATUS	TEMP	PRESSURES	SETPOINTS	INPUTS	OUTPUTS	CONFIG	ALARMS	ALARMS HISTORY	RUNTIMES
0	Default display	Evaporator water entering temp.	Discharge pressure circuit A	Cooling setpoint 1	Contact 1: on/off/heating/cooling	Output 1	SUB-MENU: User Configuration (USER)	Number of active alarms/resets**	Historic alarm code 1**	SUB-MENU: Runtimes 1
1	Mode	Evaporator water leaving temp.	Suction pressure circuit A	Cooling setpoint 2	Contact 2: setpoint selection	Output 2	SUB-MENU: Service Configuration (SERVICE)	Active alarm code 1**	Historic alarm code 2**	SUB-MENU: Runtimes 2
2	Chiller occupied mode*	Outdoor temperature	Discharge pressure circuit B*	Ice storage setpoint*	Contact 4: heating/cooling [1]*	-	SUB-MENU: Factory Configuration (FACTOR Y)	Active alarm code 2**	Historic alarm code 3**	SUB-MENU: Runtimes 3
3	Minutes left	Heat reclaim entering water temp.*	Suction pressure circuit B*	Heating setpoint 1*	Contact 4: heat reclaim [2]* OR free cooling prevention [2]	-	-	Active alarm code 3**	Historic alarm code 4**	SUB-MENU: Maintenance
4	Cooling/heating selection*	Heat reclaim leaving water temp.*	Discharge pressure circuit C*	Heating setpoint 2*	User safety loop input status	-	-	Active alarm code 4**	Historic alarm code 5**	-
5	Cooling/heating status*	Saturated discharge temperature circuit A	Suction pressure circuit C*	Auto changeover threshold (cooling mode)*	Water pump operation contact status*	-	-	Active alarm code 5**	Historic alarm code 6**	-
6	Heat reclaim selection*	Saturated suction temp. circuit A	Vacuum pressure, circuit A*	Auto changeover threshold (heating mode)*	Control box thermostat	-	-	-	Historic alarm code 7**	-
7	Total capacity in %	Suction temperature, circuit A	Vacuum pressure, circuit B*	Heat reclaim mode input setpoint*	Contact 3: demand limit selection 1*	-	-	-	Historic alarm code 8**	-
8	Capacity circuit A in %	Superheat, circuit A	-	Heat reclaim mode input dead band*	Contact 3 bis: demand limit selection 2*	-	-	-	Historic alarm code 9**	-
9	Capacity circuit B in %	Saturated discharge temp. circuit B	-	Setpoint demand limitation 1*	Contact 3 bis: demand limit selection 2*	-	-	-	Historic alarm code 10**	-
10	Capacity circuit C in %*	Saturated discharge temp. circuit B	-	Setpoint demand limitation 2*	Contact 3 bis: demand limit selection 2*	-	-	-	Historic alarm code 11**	-
11	Present demand limit in %	Suction temperature, circuit B	-	Setpoint demand limitation 3*	User safety loop input*	-	-	-	Historic alarm code 12**	-
12	Present lag limit in %*	Superheat, circuit B	-	Ramp loading*	Demand limit control limitation value*	-	-	-	Historic alarm code 13**	-
13	Setpoint in local control	Saturated discharge temp. circuit C*	-	Cooling - zero reset threshold*	Setpoint reset value*	-	-	-	Historic alarm code 14**	-
14	Setpoint occupied mode	Saturated discharge temp. circuit C*	-	Cooling - full reset threshold*	Ambient temperature value*	-	-	-	Historic alarm code 15**	-
15	Active setpoint	Suction temperature, circuit C*	-	Cooling - full reset value*	Subcooling liquid temperature, circuit A*	-	-	-	Historic alarm code 16**	-
16	Control point	Superheat, circuit C*	-	Heating - zero reset threshold*	Subcooling liquid temperature, circuit B*	-	-	-	Historic alarm code 17**	-
17	Controlled water temperature	Defrost temperature, circuit A*	-	Heating - full reset threshold*	Subcooling temperature, circuit A*	-	-	-	Historic alarm code 18**	-
18	Indicator, heat recovery in progress, circuit A*	Defrost temperature, circuit B*	-	Heating - full reset value*	Subcooling temperature, circuit B*	-	-	-	Historic alarm code 19**	-
19	Indicator, heat recovery in progress, circuit B*	System water temperature*	-	-	-	-	-	-	Historic alarm code 20**	-

Legend

- * Displayed if the configuration requires it
- ** Displayed if the alarm exists
- Not in use

- 1 For heat pump units
- 2 For cooling only units

4.3.5 - Description of the Information menu

Information menu (3)			
Item	Format	Units	Description
0	±nn.n	°C	Automatic display mode. It cycles through the following displays: 1: Controlled water temperature: temperature of the water that the unit tries to maintain at the control point.
	LOFF	-	2: Unit operating type Local Off
	L-On	-	Local On
	L-Sc	-	Local On - based on unit clock. Displayed if the CCN/clock board is installed
	CCn	-	CCN Control. Displayed if the CCN/clock board is installed
	rEM	-	Remote Control
	MASt	-	Master unit
	OFF	-	3: Unit status Off: Unit is stopped and not authorised to start.
	rEADY	-	Ready: Unit is authorised to start
	dELAY	-	Delay: Unit is in delay at start-up. This delay is active after the unit has been switched on. The delay can be configured in the User Configuration menu
	StOPPing	-	Stopping: Unit is currently stopping
	running	-	On: Unit is running or authorised to start
	triPout	-	Fault shutdown
	OvErridE	-	Limit: The operating conditions do not allow total unit operation
	dEFrOSt	-	Defrost: One circuit is in defrost mode
	FrEEcOOI	-	Free cooling: The unit operates in free cooling mode
	OCCUPIEd	-	4. Unit occupied/unoccupied status Occupied: Unit in occupied mode
	UNOCCUPIEd	-	Unoccupied: Unit in unoccupied mode
	COOL	-	5. Heating/cooling operating mode Cooling: Unit operates in cooling mode
	HEAT	-	Heating: Unit operates in heating mode
	StAndbY	-	Standby: Unit is in auto cooling/heating changeover mode, and is in standby
	Both	-	Both: The unit operates in cooling (compressors) and heating (boiler). Only with HSM operation
	ALArM	-	6: Alarm mode Alarm: Unit is totally stopped because of failure
	ALErT	-	Alert: Unit is in failure but not completely stopped
	MAStEr	-	7: Master/Slave status Master: The master/slave control is active and the unit is the master
	SLAVe	-	Slave: The master/slave control is active and the unit is the slave
			Texts 4 and 5 are not displayed if the unit is in Local off mode or if the unit is in remote control mode and contact 1 is open
1 [1]	nn		Active mode codes. Each active mode is displayed in turn. This Item is masked when nil. Pressing the enter button when a mode code is displayed causes a character text expansion to be scrolled across the four-digit display. See the description in the following table
	-		
2 [2]	occu	-	This item indicates the current unit occupied/unoccupied mode. Occupied
	unoc	-	Unoccupied
	Forc	-	The value is displayed in turn with 'Forc' when the unit is in CCN control and if this variable is forced through CCN.
3	nn.n	minutes	Start-up delay. This item indicates the minutes left before the unit can be started. This delay at start-up is always active after the unit has been switched on. The delay can be configured in the User Configuration 1 menu.
4 [2]	HEAt	-	Heating/cooling on selection: This item is accessible in read/write, if the unit is in local control mode. Heating mode selection
	COOL	-	Cooling mode selection
	Auto	-	Automatic heating/cooling mode changeover selection. Only displayed if the auto changeover function is selected (User Configuration 1 menu).
		-	
5 [2]	HEAt	-	Heating/cooling mode. This item indicates whether the unit is in cooling or heating. Displayed if the unit controls a boiler. Heating
	COOL	-	Cooling
	StbY	-	Standby: Unit is in auto cooling/heating changeover mode, and is in standby.
	both	-	Both: The unit operates in cooling (compressors) and heating (boiler). Only with HSM operation.
	Forc	-	The value is displayed in turn with 'Forc' when the unit is in CCN control and if this variable is forced through CCN.
6 [2]	Yes	-	Heat reclaim mode selection. Only displayed if the unit is a chiller and the heat reclaim option is used. The value is displayed in turn with 'Forc' when the unit is in CCN control and if this variable is forced through CCN.
	No	-	
	Forc	-	
6 [2]	Yes	-	Free cooling prevention status. Only shown if the unit is a chiller and if the free cooling option is available. The value is displayed in turn with "Forc", when the unit is in CCN control and if this variable is forced through CCN.
	No	-	
	Forc	-	
7	nnn	%	Total active capacity of unit. It is the percentage of compressor capacity used by the unit.
8	nnn	%	Total active capacity of circuit A. It is the percentage of compressor capacity used by on circuit A.
9 [2]	nnn	%	Total active capacity of circuit B. It is the percentage of compressor capacity used by on circuit B. Dual-circuit units only.
10 [2]	nnn	%	Total active capacity of circuit C. It is the percentage of compressor capacity used by on circuit C. Triple-circuit units only.
11	nnn	%	Present demand limit. This is the authorised operating capacity of the unit. See section 5.7. The value is displayed in turn with 'Forc' when the unit is in CCN control and if this variable is forced through CCN.
	Forc	-	
12 [2]	nnn	%	Present lag chiller demand limit. Displayed when the master/slave control is selected.
13 [2]	SP-1	-	Setpoint select in local mode. This point is read/write accessible. Displayed only when the unit is LOFF, L-On or L-Sc operating type. SP-1 = cooling/heating setpoint 1
	SP-2	-	SP-2 = cooling/heating setpoint 2
	AUTO	-	AUTO = active setpoint depends on schedule 2 (setpoint selection schedule). See section 5.6.1 & 4.3.11.6.

Information menu (3) continued

Item	Format	Units	Description
14 [2]	occu unoc Forc	-	Setpoint occupied mode. Occupied: cooling setpoint 1 is active Unoccupied: cooling setpoint 2 is active The value shall be displayed in turn with 'Forc' when the unit is in CCN control and if this variable is forced through CCN.
15	±nn.n	°C	Active setpoint. This is the current cooling/heating setpoint: cooling/heating setpoints 1, 2 or ice storage setpoint.
16	±nn.n Forc	°C	Control point. This is the setpoint used by the controller to adjust the temperature of the leaving or entering water (according to configuration). Control point = active setpoint + reset. See section 5.6 The value is displayed in turn with 'Forc' when the unit is in CCN control and if this variable is forced through CCN.
17	±nn.n	°C	Controlled water temperature. Water temperature that the unit tries to maintain at the control point.
18	n		Heat reclaim sequence indicator, circuit A (option).
19	n		Heat reclaim sequence indicator, circuit B (option).

[1] This item is masked when nil.

[2] This item is displayed in certain unit configurations only.

Description of operating modes (item 1 of the Information menu)

Mode #	Mode name	Description
1	Delay at start-up active	The delay at start-up operates after the unit has been switched on. If the delay has not expired, the mode is active. The delay is configured in the User Configuration 1 menu.
2	2nd cooling/heating setpoint active	The second cooling/heating setpoint is active. See section 5.6.1
3	Setpoint reset active	In this mode, the unit uses the reset function to adjust the leaving water temperature setpoint.
4	Demand limit active	In this mode, the demand at which the unit is authorised to operate is limited.
5	Ramp loading active	Ramp loading is active. This item is referenced to the allowed low and high temperature limits, controlled at the water heat exchanger in order to prevent compressor overloading. Ramp function must be configured (see User Configuration 1 menu). Ramp values can be modified (see Setpoint menu).
6	Water heat exchanger heater active	The water heat exchanger heater is active.
7	Evaporator pump reversal in effect	The unit is fitted with two evaporator water pumps and reversal between pumps is in effect.
8	Evaporator pump periodic start	The unit is stopped and the pump is started each day at 14.00 p.m. for two seconds. This function needs to be configured in the User Configuration 2 menu.
9	Night mode (low noise level)	The night mode (low noise level) is active. The number of fans is reduced (if operating conditions allow) and unit capacity can be limited.
10	Unit in SM control	Unit is in control of a System Manager (FSM, CSM III or HSM).
11	Master/slave link active	Unit is connected to a secondary unit by a master slave link and the master/slave modes are active.
12	Auto heating/cooling changeover active	If the unit is in auto mode, the heating/cooling changeover is automatic, based on the outdoor temperature.
13	Free cooling mode active	The free cooling mode is active.
14	Heat reclaim mode active	The heat reclaim mode is active.
15	Electric heating stages active	The electric heating stages are active.
16	Low water entering temperature protection in heating mode	The unit is in heating mode and compressor start is not authorised, as the entering water temperature is below 10°C.
17	Boiler active	The unit controls a boiler and this is operating.
18	Ice storage mode active	The unit operates in cooling mode and the ice storage mode is active.
19, 20	Defrost	19 = circuit A, 20 = circuit B. The unit is in heating mode, and the defrost sequence is active on the relevant circuit.
21, 22, 23	Low suction temperature protection	21 = circuit A, 22 = circuit B, 23 = circuit C. Protection for evaporator low suction temperature circuit is active. In this mode, circuit capacity is not authorised to rise and the circuit can be unloaded.
24, 25, 26	Hot gas protection	24 = circuit A, 25 = circuit B, 26 = circuit C. Hot gas discharge protection is active. In this mode, the circuit capacity cannot increase, and the circuit may be unloaded.
27, 28, 29	High pressure protection	27 = circuit A, 28 = circuit B, 29 = circuit C. The circuit is in high pressure protection mode because the HP protection threshold has been exceeded. Circuit has been unloaded and the circuit capacity is not authorised to rise.
30, 31, 32	Low superheat protection	30 = circuit A, 31 = circuit B, 32 = circuit C. The circuit is in the low superheat protection mode to prevent the compressors drawing in liquid refrigerant.

4.3.6 - Description of the Temperatures menu

Temperatures menu [1]			
Item	Format	Units	Comments
0	±nn.n	°C	Heat exchanger entering water temperature
1	±nn.n	°C	Heat exchanger leaving water temperature
2	±nn.n	°C	Outdoor temperature
3 [1]	±nn.n	°C	Heat reclaim entering water temperature (only if heat reclaim option is configured)
4 [1]	±nn.n	°C	Heat reclaim leaving water temperature (only if heat reclaim option is configured)
5	±nn.n	°C	Saturated condensing temperature, circuit A
6	±nn.n	°C	Saturated suction temperature, circuit A
7	±nn.n	°C	Suction temperature, circuit A
8	±nn.n	°C	Superheat temperature, circuit A
9	±nn.n	°C	Saturated condensing temperature, circuit B
10	±nn.n	°C	Saturated suction temperature, circuit B
11	±nn.n	°C	Suction temperature, circuit B
12	±nn.n	°C	Superheat temperature, circuit B
13 [1]	±nn.n	°C	Saturated condensing temperature, circuit C (displayed if circuit C exists)
14 [1]	±nn.n	°C	Saturated suction temperature, circuit C (displayed if circuit C exists)
15 [1]	±nn.n	°C	Suction temperature, circuit C (displayed if circuit C exists)
16 [1]	±nn.n	°C	Superheat temperature, circuit C (displayed if circuit C exists)
17,18	±nn.n	°C	Defrost temperature (displayed if unit is in heat pump mode) 17 = circuit A, 18 = circuit B
19 [1]	±nn.n	°C	Chilled water system temperature. This item is only displayed when the master/slave option is configured.

[1] This item is displayed in certain unit configurations only

4.3.7 - Description of the Pressures menu

Pressures menu [1]			
Item	Format	Units	Comments
0	nnnn	kPa	Discharge pressure, circuit A. Relative pressure.
1	nnn	kPa	Suction pressure, circuit A. Relative pressure.
2	nnnn	kPa	Discharge pressure, circuit B. Relative pressure.
3	nnn	kPa	Suction pressure, circuit B. Relative pressure.
4	nnnn	kPa	Discharge pressure, circuit C. Relative pressure.
5	nnn	kPa	Suction pressure, circuit C. Relative pressure.
6 [1]	±nnn	kPa	Vacuum pressure, circuit A. Only displayed if heat reclaim option is used.
7 [1]	±nnn	kPa	Vacuum pressure, circuit B. Only displayed if heat reclaim option is used.
8 [1]	nnn	kPa	Suction pressure, refrigerant pump, circuit A. Only displayed if the free cooling option is available.
9 [1]	nnn	kPa	Discharge pressure, refrigerant pump, circuit A. Only displayed if the free cooling option is available.
10 [1]	±nnn	kPa	Differential pressure at the terminals of the refrigerant pump, circuit A. Only displayed if the free cooling option is available.
11 [1]	nnn	kPa	Suction pressure, refrigerant pump, circuit B. Only displayed if the free cooling option is available.
12 [1]	nnn	kPa	Discharge pressure, refrigerant pump, circuit B. Only displayed if the free cooling option is available.
13 [1]	±nnn	kPa	Differential pressure at the terminals of the refrigerant pump, circuit B. Only displayed if the free cooling option is available.
14 [1]	nnn	kPa	Suction pressure, refrigerant pump, circuit C. Only displayed if the free cooling option is available.
15 [1]	nnn	kPa	Discharge pressure, refrigerant pump, circuit C. Only displayed if the free cooling option is available.
16 [1]	±nnn	kPa	Differential pressure at the terminals of the refrigerant pump, circuit C. Only displayed if the free cooling option is available.

[1] This item is displayed in certain unit configurations only.

4.3.8 - Description of the Setpoints menu

Setpoints menu [2]				
Item	Format	Units	Range	Comments
0	±nn.n	°C	-28 to 26	This item lets you modify Cooling setpoint 1 .
1	±nn.n	°C	-28 to 26	This item lets you modify Cooling setpoint 2 .
2 [1]	±nn.n	°C	-28 to 0	This item lets you modify the ice storage setpoint.
3 [1]	nnn	°C	20 to 50	This item lets you modify Heating setpoint 1 , only displayed for heat pumps.
4	nn.n	°C	20 to 50	This item lets you modify Heating setpoint 2 , only displayed for heat pumps.
5 [2]	±nn.n	°C	3.8 to 50	Automatic changeover threshold, cooling mode. This item lets you display and modify the outdoor temperature threshold at which the unit changes over in cooling mode. Displayed only if the auto cooling/heating changeover function is selected.
6 [2]	±nn.n	°C	0 to 46	Automatic changeover threshold, heating mode. This item lets you display and modify the outdoor temperature threshold at which the unit changes over in heating mode. Displayed only if the auto cooling/heating changeover function is selected and if the unit is a heat pump. The heating threshold must be 3.8°C below the cooling threshold, otherwise the new setpoint will be rejected.
7 [2]	nn.n	°C	35 to 60	For the desuperheater option, this item permits control the minimum condensing temperature setpoint.
8 [2]	nn.n	°C	2.7 to 15	This item lets you display and modify the heat reclaim dead band.
9	nnn	%	0 to 100	Demand limit 1 setpoint. Limitation by volt-free contact. This item is used to define the maximum capacity that the unit is authorised to use, if the demand limit contact(s) activate limit 1. Contact control depends on the configuration.
10 [2]	nnn	%	0 to 100	Demand limit 2 setpoint. Limitation by volt-free contact. This item is used to define the maximum capacity that the unit is authorised to use, if the demand limit contact(s) activate limit 2. Contact control depends on the configuration. Displayed and used only for units with energy management option.
11 [2]	nnn	%	0 to 100	Demand limit 3 setpoint. Limitation by volt-free contact. This item is used to define the maximum capacity that the unit is authorised to use, if the demand limit contact(s) activate limit 3. Contact control depends on the configuration. Displayed and used only for units with energy management option.
12 [2]	±nn.n	°C/min	0.1 to 1.1	Cooling ramp loading rate. This parameter is only accessible if the ramp function is validated in the User Configuration 1 menu. This item refers to the maximum permitted water heat exchanger low temperature rates (°C/min). When capacity loading is effectively limited by the ramp, mode 7 is active.
13 [2]	±nn.n	°C/min	0.1 to 1.1	Heating ramp loading rate. This parameter is only accessible if the ramp function is validated in the User Configuration 1 menu. This item refers to the maximum permitted water heat exchanger high temperature rates (°C/min). When capacity loading is effectively limited by the ramp, mode 7 is active.
14 [2]	±nn.n	[3]	[3 bis]	Zero reset threshold, cooling mode.
15 [4]	±nn.n	[3]	[3 bis]	Full reset threshold, cooling mode.
16 [4]	±nn.n	°C	-16.6 to 16.6	Full reset value, cooling mode.
17 [4]	±nn.n	[3]	[3 bis]	Zero reset threshold, heating mode.
18 [4]	±nn.n	[3]	[3 bis]	Full reset threshold, heating mode.
19 [4]	±nn.n	°C	-16.6 to 16.6	Full reset value, heating mode.

[1] This item shall be masked when not used.

[2] This item is displayed in certain unit configurations only.

[2] Depends on the configuration of the reset type. If reset type is 1, 2 or 4 the unit is °C; if reset type is 3, the unit is mA.

[3 bis] The scale depends on the reset type selected.

[4] Depends on the value of items 9 or 10 of the user configuration menu 1.

If the reset type selection point

= 0: reset not selected

= 1: reset based on outside temperature

= 2: reset based on temperature difference

= 3: reset based on 4-20 mA control

= 4: reset based on room temperature

Reset thresholds in cooling or heating mode

Reset threshold	Zero	Full
Reset based on outdoor air temperature	-10 to 51.6°C	-10 to 51.6°C
Reset based on temperature difference	0 to 13.6	0 to 13.6
Reset based on 4-20 mA control	0 to 11.1 °C	0 to 11.1 °C
Reset based on room temperature	-10 to 51.6°C	-10 to 51.6°C

4.3.9 - Description of the Inputs menu

Inputs menu [1]			
Item	Format	Units	Comments
0	oPEn/CLoS	-	Remote contact 1 status (on/off switch). If the auto cooling/heating changeover function is not selected (User Configuration 1), this contact is used to start and stop the unit. If the auto cooling/heating changeover function is selected, this contact is multiplexed with contact 4 to permit starting and stopping the unit and the selection of heating/cooling/auto. This contact is only valid, if the unit is in the remote operating control (rEM) mode.
1	oPEn/CLoS	-	Remote contact 2 status. Status of remote contact 2. This contact permits the selection of a setpoint. This contact is only active if the unit is in the remote operation type. See section 3.6.1 for the description of this contact and section 3.6.4 for the description of the setpoint selection function.
2 [1]	oPEn/CLoS	-	Remote contact 4 status. If the automatic cooling/heating changeover function is not selected (User Configuration 1) this contact is used for the selection of the heating or cooling operating mode. If the automatic cooling/heating changeover function is selected, this contact is multiplexed with contact 1 to permit the starting and stopping of the unit and the selection of heating/cooling auto. This contact is only valid, if the unit is in the remote operation control (rEM) mode.
3 [1]	oPEn/CLoS	-	Remote contact 4 status. This item is only displayed on chillers. If the heat reclaim option is available, this contact allows remote selection of heat reclaim. If the free cooling option is available, this contact allows prevention of free cooling mode operation.
4	oPEn/CLoS	-	Status user safety contact or water flow control contact. If the contact is open, the unit stops.
5 [1]	oPEn/CLoS	-	Contact status: pump operation status.
6	oPEn/CLoS	-	Control box thermostat contact or reverse rotation contact.
7 [1]	oPEn/CLoS	-	Remote contact 3 status. This contact permits selection of a demand limit. It is located on board PD5-BASE.
8 [1]	oPEn/CLoS	-	Remote contact 3 bis status. This contact is only used if the energy management option is used. It is multiplexed with contact 3 to permit selection of one of three demand limits.
9 [1]	oPEn/CLoS	-	Ice storage remote contact status. This contact is located on board NRCP2 of the energy management option. It is used during unit occupied periods to permit selection of a setpoint or ice storage setpoint.
10 [1]	oPEn/CLoS	-	Unit occupied continued remote contact status. This contact is only used on units with energy management option to maintain the occupied mode.
11 [1]	oPEn/CLoS	-	User safety loop input status. This contact is accessible on the energy management option board. It can be used for any customer safety loop that requires unit shut-down if it is closed.
12 [1]	nn.n	mA	Demand limit signal. This contact is only displayed when the energy management option is selected. This contact permits changing the lowest value, based on a linear interpolation from 0 to 100% depending on the input value.
13 [1]	nn.n	mA	Setpoint reset signal.
14 [1]	°C		Room temperature value, only used if the energy management option is selected and the room temperature sensor is installed.
15 [1]	°C		Liquid subcooling temperature, circuit A. Only used if the heat reclaim option is selected.
16 [1]	°C		Liquid subcooling temperature, circuit B. Only used if the heat reclaim option is selected.
17 [1]	°C		Subcooling temperature, circuit A. Only used if the heat reclaim option is selected.
18 [1]	°C		Subcooling temperature, circuit B. Only used if the heat reclaim option is selected.
19 [1]	oPEn/CLoS	°C	Heat reclaim condenser water flow control. Controls the heat reclaim condenser water circulation.

[1] This item is displayed in certain unit configurations only

4.3.10 - Description of the Outputs/Tests menu

4.3.10.1 - General

This menu displays the status of the controller outputs. Moreover, when the machine is fully stopped (LOFF) the outputs can be activated for manual tests (the access to the tests is password controlled).

4.3.10.2 - Menu description

Main outputs menu			
Item	Format	Units	Description
0	OUtPUts 1	-	This menu permits access to outputs menu 1.
1	OUtPUts 2	-	This menu permits access to outputs menu 2.
Outputs status & Tests menu			
Item	Format	Units	Description
0	OUtPUts 1 Menu	-	When selected this item authorises return to the previous menu.
1	b ₁ b ₂ b ₃ b ₄ tESt FAIL Good	-	Circuit A compressors , command status b ₁ = compressor A1 b ₂ = compressor A2 b ₃ = compressor A3 b ₄ = compressor A4 In test mode , the Arrow buttons display 0001, 0010, 0100 and 1000 in succession, so as to force the compressor outputs in turn. During the test phase, power to the compressor is switched on for 10 seconds only. It is then not possible to restart the compressor for a further 30 seconds. When the test is completed the following is displayed: - Fail: displayed if the test has failed because the compressor was not started or run in reverse rotation. - Good: displayed if test was successful
2	b ₁ b ₂ b ₃ b ₄ tESt FAIL Good	-	Circuit B compressor , command status b ₁ = compressor B1 b ₂ = compressor B2 b ₃ = compressor B3 b ₄ = compressor B4 In test mode... as above
3	b ₁ b ₂ b ₃ b ₄ tESt FAIL Good	-	Circuit C compressor , command status b ₁ = compressor C1 b ₂ = compressor C2 b ₃ = compressor C3 b ₄ = compressor C4 In test mode... as above
4	b ₁ b ₂ tESt	-	4-way reversing cycle valve status . In test mode, the arrow keys successively display 01 and 10, in order to authorise the test for each valve in turn. b ₁ = valve circuit A b ₂ = valve circuit B This item is only displayed for heat pump units.
5	b ₁ b ₂ b ₃ b ₄ tESt	-	Compressor heater status, circuit A b ₁ = compressor heater A1 b ₂ = compressor heater A2 b ₃ = compressor heater A3 b ₄ = compressor heater A4 In test mode , the Arrow buttons display 0001, 0010, 0100 and 1000 in succession, so as to force the compressor heater outputs in turn.
6	b ₁ b ₂ b ₃ b ₄ tESt	-	Compressor heater status, circuit B b ₁ = compressor heater B1 b ₂ = compressor heater B2 b ₃ = compressor heater B3 b ₄ = compressor heater B4 In test mode , the Arrow buttons display 0001, 0010, 0100 and 1000 in succession, so as to force the compressor heater outputs in turn.
7	b ₁ b ₂ b ₃ b ₄ tESt	-	Compressor heater status, circuit C b ₁ = compressor heater C1 b ₂ = compressor heater C2 b ₃ = compressor heater C3 b ₄ = compressor heater C4 In test mode , the Arrow buttons display 0001, 0010, 0100 and 1000 in succession, so as to force the compressor heater outputs in turn.
8	0 to 6 tESt	-	Fan status, circuit A . Permits selection of the fan to be tested. 1 = fan A1 2 = fan A2 3 = fan A3 4 = fan A4 5 = fan A5 6 = fan A6
9	0 to 6 tESt	-	Fan status, circuit B . Permits selection of the fan to be tested. 1 = fan B1 2 = fan B2 3 = fan B3 4 = fan B4 5 = fan B5 6 = fan B6

Outputs status & Tests menu (continued)

Item	Format	Units	Description
10	0 to 6 tESt		Fan status, circuit C. Permits selection of the fan to be tested. 1 = fan C1 2 = fan C2 3 = fan C3 4 = fan C4 5 = fan C5 6 = fan C6
11	b ₁ b ₂ b ₃ b ₄ tESt		Alarm status b ₁ = alarm relay b ₂ = alert relay b ₃ = general alarm relay (present if energy management option is used) b ₄ = critical alarm relay output. Caution: If this output is connected, its activation will disconnect the general unit power supply.
12	nnn tESt	%	EXV A position 0% = EXV closed; 100% = EXV open In test mode this permits selection of the required position.
13	nnn tESt	%	EXV B position 0% = EXV closed; 100% = EXV open In test mode this permits selection of the required position.
14	nnn tESt	%	EXV C position 0% = EXV closed; 100% = EXV open In test mode this permits selection of the required position.
15	nnn tESt	%	Fan speed, circuit A. Only displayed if a variable speed controller is selected in circuit A. In test mode, this permits selection of the required speed.
16	nnn tESt	%	Fan speed, circuit B. Only displayed if a variable speed controller is selected in circuit B. In test mode, this permits selection of the required speed.
17	nnn tESt	%	Fan speed, circuit C. Only displayed if a variable speed controller is selected in circuit C. In test mode, this permits selection of the required speed.
18	On Stop tESt FAIL Good Forc	-	Evaporator water pump #1 command status. Not displayed if the unit does not control a pump. On: pump is running Stop: pump is stopped Forc: this item is displayed only when the unit is stopped locally (LOFF). selecting this item authorises turning on the pump with no delay and for an unlimited length of time. The pump will remain on until any button of the user interface is pressed: it is then immediately stopped. If the unit is in CCN control, then the pump status is displayed in turn with "Forc" if the pump status is forced through CCN. During the test phase , power to the pump is switched on for 10 seconds only. When the test is completed the following is displayed: - Fail: displayed if the test has failed because the pump was not started - Good: displayed if the test was successful
19	On OFF tESt FAIL Good Forc	-	Evaporator water pump #2 command status. Not displayed if the unit does not control a secondary pump. On: pump is running Stop: pump is stopped Forc: this item is displayed only when the unit is stopped locally (LOFF). selecting this item authorises turning on the pump with no delay and for an unlimited length of time. The pump will remain on until any button of the user interface is pressed: it is then immediately stopped. If the unit is in CCN control, then the pump status is displayed in turn with "Forc" if the pump status is forced through CCN. During the test phase , ...as above

Submenu outputs 2 (selection)

Item	Format	Units	Description
0	OUtPUts 2 Menu		When selected this item authorises return to the previous menu.
1	On OFF Forc tESt FAIL Good		Heat reclaim condenser pump status. Only displayed when the heat reclaim option is selected. Forc: This item is only displayed when the unit is in Local off (LOFF) mode. Selecting this item permits starting up the pump without delay and for an unlimited period. The pump stays on until any button on the user interface is pressed: it is then immediately stopped. If the unit is under CCN control, the pump status is displayed alternatively with 'Forc', if the status is forced by CCN.
2	b ₁ b ₂		Heat exchanger heater status (b1) and heat reclaim condenser heater status (b2).
3	b ₁ b ₂ b ₃		Hot gas bypass valve status. Only displayed if the hot gas bypass option is selected. b ₁ = hot gas bypass valve, circuit A b ₂ = hot gas bypass valve, circuit B b ₃ = hot gas bypass valve, circuit C
4	nnn tESt	%	Heat reclaim condenser water valve position. Only displayed if the heat reclaim option is selected.
5	b ₁ b ₂ b ₃ b ₄		Heat reclaim operation valve status, circuit A. b ₁ = air condenser entering valve, circuit A b ₂ = water condenser entering valve, circuit A b ₃ = air condenser leaving valve, circuit A b ₄ = water condenser leaving valve, circuit A
6	b ₁ b ₂ b ₃ b ₄		Heat reclaim operation valve status, circuit B. b ₁ = air condenser entering valve, circuit B b ₂ = water condenser entering valve, circuit B b ₃ = air condenser leaving valve, circuit B b ₄ = water condenser leaving valve, circuit B
7	0 to 4 tESt		Additional heating stage status. 1 = stage 1 2 = stage 2 3 = stage 3 4 = stage 4

Submenu outputs 2 (selection) (continued)

Item	Format	Units	Description
8	On OFF tESt		Boiler operating status. On: operating OFF: stopped
9	b ₁ b ₂ b ₃		Free cooling 3-way valve status (only displayed when the free cooling option is selected). b ₁ = 3-way valves, circuit A b ₂ = 3-way valves, circuit B b ₃ = 3-way valves, circuit C 0 corresponds to a closed valve (cooling position) and 1 corresponds to an open valve (free cooling position)
10	b ₁ b ₂ b ₃ tESt		Free cooling refrigerant pump status (only displayed when the free cooling option is selected). b ₁ = pump, circuit A b ₂ = pump, circuit B b ₃ = pump, circuit C
11	nn.n tESt		Unit capacity 0-10 V signal value (10 V = 100 %). Only displayed if the energy management option is selected.
12	b ₁ b ₂		Chiller operating status b ₁ = ready (ready-to-start or in operation) b ₂ = in operation
13	YES/no		Used for local interface test only. Lights or flashes all LEDs and blocks, so as to check that they are working properly.

4.3.10.3 - Manual tests

This function allows the user to test the outputs individually, if the machine is completely shut down (LOFF). To carry out a manual test use the arrow keys to access the output to be tested and press the Enter key (longer than 2 seconds) to activate the modification mode. The password is automatically requested, if it has not previously been verified. The Outputs/Test LED on the user interface begins to flash. Enter the desired test value and again press Enter to start the test. 'TEST' is displayed on the 4-digit display alternately with the value tested. The Outputs/Test LED stops flashing. Press the Enter key or an arrow key to stop the test.

4.3.11 - Description of the Configuration menu**4.3.11.1 - General**

This menu can be used to display and modify all configurations: Factory, Service and User. Only the User Configuration can be modified by the end-user. The Factory, Service and master/slave configurations are not described in this document. A configuration can only be modified if the unit is fully stopped (LOFF).

The menus User 1 [USER 1] and User 2 [USER 2] are password-protected. The other menus are directly accessible, except if item 11 of the User 2 menu (password for all configurations) has been validated.

4.3.11.2 - Password

A password must be entered in order to access the test function or to modify a configuration. It is automatically requested, if necessary: 'EntEr PASS' is displayed on the 4-digit display and the configuration menu LED flashes, indicating that the modification mode is active. Press the arrow keys until the value '11' is displayed on the 4-digit display. Press Enter to validate this. The configuration menu LED stops flashing. If the password is correct, 'Good' is displayed. If the password is incorrect, 'PASS incorrEct' is displayed. The User password has a default value of 11.

This value can be modified through the Service configuration. The password can be entered if the unit is fully stopped, otherwise 'ACCES dEniEd' (access denied) will be displayed on the 4-digit display. The controller automatically deactivates the password after 5 minutes without activity (i.e. no buttons pressed) or after powering up.

Sub-menu user configuration							
Item	User 1 [USER1]	User 2 [USER2]	Date [dAtE]	Schedule 1 [SchEdULe 1MEnu]	Schedule 2 [SchEdULe 2 MEnu]	Holidays [HOLidAy MEnu]	Broadcast [BrodCAST]
0	Return to previous menu	Return to previous menu	Return to previous menu	Return to previous menu	Return to previous menu	Return to previous menu	Return to previous menu
1	Selection of lead circuit	Periodic pump start-up	Hour	SUB-MENU: Period 1 [PERlod 1]	SUB-MENU: Period 1 [PERlod 1]	SUB-MENU: Holidays 1 [HOLidAy 1]	Broadcast acknowledge selection
2	Load sequence selection	Night mode - start hour	Day of the week	SUB-MENU: Period 2 [PERlod 2]	SUB-MENU: Period 2 [PERlod 2]	SUB-MENU: Holidays 2 [HOLidAy 2]	Broadcast activation
3	Ramp selection	Night mode - end hour	Day and month	SUB-MENU: Period 3 [PERlod 3]	SUB-MENU: Period 3 [PERlod 3]	SUB-MENU: Holidays 3 [HOLidAy 3]	Outdoor temperature broadcast bus
4	Start-up delay	Night mode maximum demand	Year	SUB-MENU: Period 4 [PERlod 4]	SUB-MENU: Period 4 [PERlod 4]	SUB-MENU: Holidays 4 [HOLidAy 4]	Outdoor temperature broadcast element
5	Water pump selection	Number clock 1	Summertime activation	SUB-MENU: Period 5 [PERlod 5]	SUB-MENU: Period 5 [PERlod 5]	SUB-MENU: Holidays 5 [HOLidAy 5]	
6	Water pump changover delay	Number clock 2	Summertime start month	SUB-MENU: Period 6 [PERlod 6]	SUB-MENU: Period 6 [PERlod 6]	SUB-MENU: Holidays 6 [HOLidAy 6]	
7	Pump shutdown in standby mode	CCN element number	Summertime start day of the week	SUB-MENU: Period 7 [PERlod 7]	SUB-MENU: Period 7 [PERlod 7]	SUB-MENU: Holidays 7 [HOLidAy 7]	
8	Verification of the water flow rate if the pump has stopped	CCN bus number	Summertime start week of the month	SUB-MENU: Period 8 [PERlod 8]	SUB-MENU: Period 8 [PERlod 8]	SUB-MENU: Holidays 8 [HOLidAy 8]	
9	Setpoint reset selection, cooling mode	Interface text language	Summertime end month			SUB-MENU: Holidays 9 [HOLidAy 9]	
10	Setpoint reset selection, heating mode	Extended display selection	Summertime end day of the week			SUB-MENU: Holidays 10 [HOLidAy 10]	
11	Automatic heating/cooling changeover selection	Password for all user configurations	Summertime end week of the month			SUB-MENU: Holidays 11 [HOLidAy 11]	
12	Demand limit selection	Software version number				SUB-MENU: Holidays 12 [HOLidAy 12]	
13	Maximum demand limit current value	Boiler activation temperature threshold				SUB-MENU: Holidays 13 [HOLidAy 13]	
14	Minimum demand limit current value	Ice storage mode authorisation				SUB-MENU: Holidays 14 [HOLidAy 14]	
15	Electric heating stage operation threshold	Free cooling authorisation temperature limit (max.)				SUB-MENU: Holidays 15 [HOLidAy 15]	
16	Electric heating stage operation schedule	Authorisation of pre-cooling by free cooling				SUB-MENU: Holidays 16 [HOLidAy 16]	
17	Electric heating safety stage threshold	Maximum duration of full load operation in free cooling					
18	Quick start-up, electric heater stages in defrost mode						

NOTE: The items in brackets show what is displayed on the user interface.

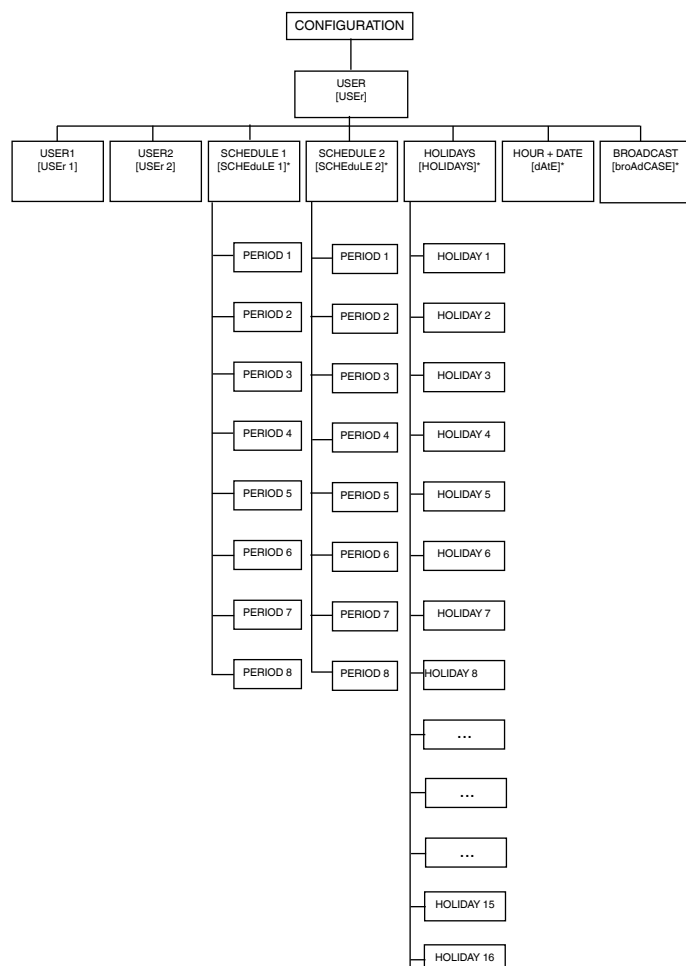

Sub-menu period configuration*

Item	Period 1 to 8 [PERiod X MEnu]*
0	Return to previous menu
1	Start of occupied period
2	End of occupied period
3	Selection Monday
4	Selection Tuesday
5	Selection Wednesday
6	Selection Thursday
7	Selection Friday
8	Selection Saturday
9	Selection Sunday
10	Selection holidays

SUB-MENU HOLIDAY CONFIGURATION*

Item	HOLIDAYS 1 to 16 [HoLidAy X MEnu]*
0	Return to previous menu
1	Start month holidays
3	Start day holidays
4	Number of days, holidays

* only displayed if configuration requires.

NOTE: The items in brackets show what is displayed on the user interface.

4.3.11.3 - Description of the User 1 Configuration sub-menu

User 1 Configuration sub-menu			
Item	Format	Units	Comments
0	USER MEnu	-	When selected this item authorises return to the previous menu.
1 [1]	0/1/2/3	-	Selection of lead circuit. 0 = automatic; 1 = circuit A; 2 = circuit B; 3 = circuit C
2	0/1	-	Load sequence selection. 0 = balanced loading: compressors belonging to different circuits are started alternatively. 1 = priority loading: all compressors in the same circuit are started, before starting those in another circuit.
3	YES/no	-	Ramp loading select. Yes = ramp enabled No = ramp disabled This configuration enables the ramp to be activated for heating or cooling (depending on configuration). This item refers to the authorised low or high temperature rates, controlled by the water heat exchanger (°C/min). Ramp setting value can be configured in the Setpoint menu.
4	1 to 15	min	Delay at start-up. This value is reinitialised after power-up or when both circuits are halted by local, remote or CCN command. No compressor will be started up until this pause has expired. However, the evaporator pump command will be activated immediately. The safety lockout loop will not be checked until the pause has expired.
5	0/1/2/3/4	-	Pump sequence select 0 = no pump 1 = one pump only 2 = two pumps with auto rotation 3 = pump #1 manual select 4 = pump #2 manual select If the auto sequence is selected, the pump change-over occurs when the rotation delay is elapsed. If the manual sequence is selected then, the selected pump is used in priority. Change-over occurs if one pump fails.
6 [1]	24 to 3000	hours	Pump changeover delay. Displayed if auto pump sequence is selected. This parameter is used for pump auto-rotation: the control tries to limit the pump run time difference to the pump changeover delay value. Change-over between pumps occurs when this difference becomes greater than the configured pump changeover delay.
7 [1]	«YES/no»	-	Pump shutdown in standby mode Displayed if the unit controls a water pump. If this parameter is validated, the pump will be shut down when the standby mode is active (in automatic heating/cooling changeover). It automatically restarts in heating or cooling mode.
8 [1]	«YES/no»	-	Activation of the water flow control verification, when the pump is stopped. Prevents the water flow alarm, when the pump has stopped and when the user/water flow rate safety loop is closed.
9	0/1/2/3/4	-	Cooling setpoint reset select. 0 = reset not selected 1 = reset based on outdoor temperature 2 = reset based on return water temperature 3 = reset based on 4-20 mA input (of the energy management option is used) 4 = reset based on room temperature (if the energy management option is used and the room temperature sensor is installed)
10	0/1/2/3	-	Heating setpoint reset select. Only displayed in heat pump mode. 0 = reset not selected 1 = reset based on outdoor temperature 2 = reset based on return water temperature 3 = reset based on 4-20 mA input (of the energy management option is used)
11	«YES/no»	-	Automatic cooling/heating changeover select.
12	0/1/2	-	Demand limit 0 = no demand limit 1 = demand limit generated by the contact inputs 2 = demand limit generated by the 0-20 mA input
13 [1]	nn	mA	Maximum demand limit signal. Only displayed if the energy management option is used.
14 [1]	nn	mA	Minimum demand limit signal. Only displayed if the energy management option is used.
15 [1]	nnn	°C	Boiler threshold. Outdoor air temperature limit; if the temperature is lower, the heat pump is stopped or only the boiler is used for hot water production. Only for heat pumps controlling an additional boiler.
16 [1]	0 to 60	minutes	Electric heating stage operation schedule. Permits configuration of a start-up delay after unit start-up during which the electric heater stages are not allowed to start.
17 [1]	«YES/no»	-	Electric heating safety stage. In this configuration the last electric heating stage is only activated in the safety mode (in case of a unit fault that prevents unit operation in heat pump mode). The other electric heating stages operate normally.
18 [1]	«YES/no»	-	Electric heater stages in defrost mode. If a circuit switches to defrost mode, the electric heater stages are allowed to start up immediately.
19 [1]	-20 to 0	°C	Minimum outside temperature threshold in heating mode. If the outside temperature is below this value, no compressor is allowed to start.

[1] This item shall be masked when not used.

4.3.11.4 - Description of the User 2 Configuration sub-menu

User 2 Configuration sub-menu			
Item	Format	Units	Comments
0 [1]	USER 2 Menu		When selected this item authorises return to the previous menu.
1	«YES/no»	-	Periodic pump quick-start of the water pump(s) Yes = the pump is started periodically when the unit is manually stopped. No = periodic pump start is disabled When the unit is manually stopped (e.g. during the winter season) the pump is started each day at 14.00 hours for 2 seconds. If two pumps are available, pump #1 is started on odd days and pump #2 on even days.
2	n ₁ n ₂ n ₃ n ₄ 00:00 to 23:59	-	Night control mode - start time* Authorises entering the time of day at which the night control mode starts. During this period the fan runs at low speed (to reduce fan noise) and unit capacity is limited to the maximum night values.
3	n ₁ n ₂ n ₃ n ₄ 00:00 to 23:59	-	Night control mode - end time* Authorises entering the time of day at which the night control mode ends.
4	0 to 100	%	Minimum demand limit threshold in night mode. The unit capacity is never unloaded below this threshold, when the night mode is active (low noise level).
5	0 or 65 to 99	-	Schedule 1 clock number (for unit on/off schedule, see section 4.3.11.6) 0 = schedule in local operating mode 65 to 99 = schedule in CCN operating mode
6	0 or 65 to 99	-	Schedule 2 clock number (schedule for setpoint selection, see section 4.3.11.6) 0 = schedule in local operating mode 65 to 99 = schedule in CCN operating mode
7	1 to 239	-	CCN element address No two network elements can have the same element number and bus number at the same time.
8	0 to 239	-	CCN bus number No two network elements can have the same element number and bus number at the same time.
9	0/1/2/3/4	-	User interface description text language 0 = English 1 = Spanish 2 = French 3 = Portuguese 4 = other (requires additional remote downloading)
10	«YES/no»	-	Extended display selection YES = description of available menu No = description of deactivated menu. This item permits activation or deactivation of the display showing the menu items.
11	«YES/no»	-	Activation of the user password for all user configurations: date, time schedules and broadcast.
12	nnn	-	Software version number This item shows the number of the software version used by this controller. Access is read only.
13 [1]	nnn	°C	Boiler activation temperature threshold. If the outside temperature is below this value, the boiler is started.
14	«YES/no»	-	Ice storage mode authorisation YES = the ice storage mode is authorised No = the ice storage mode is not authorised
15	nn	°C	Outdoor temperature limit (maximum) for authorisation of free cooling
16	«YES/no»	-	Authorisation of pre-cooling by free cooling YES = pre-cooling by the free cooling mode is authorised (i.e. free cooling is started when the difference between the outside temperature and the leaving water temperature is higher than the threshold value of 8°C without taking into consideration the temperature difference between the outside temperature and the set-point). No = pre-cooling by the free cooling mode is not authorised (i.e. free cooling is only started when the difference between the outside temperature and the set-point is higher than the threshold value of 8°C).
17	5 to 60	minutes	Maximum duration of full load operation in free cooling If the unit operates at full load in free cooling for this duration, and if the set-point temperature is not satisfied, the free cooling session must be stopped to allow the unit to restart in normal cooling mode (using the compressors).

* n₁n₂: hours (00 to 23). The first time the Enter button is continuously pressed, the first two characters in the 4-digit display flash so that hours can be adjusted.
n₃n₄: minutes (00 to 59). Continuous pressing of the Enter key again causes the last two characters to flash so that minutes can be adjusted.

[1] This item shall be masked when not used.

4.3.11.5 - Description of Date and Time configuration sub-menu

Date & Time configuration sub-menu		
Item	Format	Comments
0	dAtE MEnu	When selected this item authorises return to the previous menu.
1	n ₁ n ₂ n ₃ n ₄ 00:00 to 23:59	Current time setting. n ₁ n ₂ : hours (00 to 23). The first time the Enter button is continuously pressed, the first two characters in the 4-digit display flash so that hours can be adjusted. n ₃ n ₄ : minutes (00 to 59). Continuous pressing of the Enter key again causes the last two characters to flash and minutes can be adjusted.
2	«Mon» «tUe» «uEd» «tHu» «Frl» «SAt» «Sun»	Current day of week setting. Monday Tuesday Wednesday Thursday Friday Saturday Sunday
3	n ₁ n ₂ n ₃ n ₄ 01:01 to 31:12	Current day and month setting. The control mode is the same as for the time. n ₁ n ₂ :day (01 to 31). n ₃ n ₄ :month (01 to 12).
4	n ₁ n ₂ n ₃ n ₄	Current year setting.
5	YES/no	Summertime activation. One hour is added when summertime starts, and one hour is deducted when it ends. The time changes at 2.00 am.
6	nn	Summertime start month control.
7	«Mon» «tUe» «uEd» «tHu» «Frl» «SAt» «Sun»	Summertime start day of the week control. Monday Tuesday Wednesday Thursday Friday Saturday Sunday
8	0 to 5	Summertime start week of the month control.
9	nn	Summertime end month control.
10	«Mon» «tUe» «uEd» «tHu» «Frl» «SAt» «Sun»	Summertime end day of the week control. Monday Tuesday Wednesday Thursday Friday Saturday Sunday
11	nn	Summertime end week of the month control.

4.3.11.6 - Description of the Time Schedules sub-menus

The control provides two timer programs: schedule 1 and schedule 2 that can be activated.

The first timer program (schedule #1) provides a means to automatically switch the unit from an occupied mode to an unoccupied mode: the unit is started during occupied periods.

The second timer program (schedule #2) provides a means to automatically switch the active setpoint from an occupied setpoint to an unoccupied setpoint: cooling setpoint 1 is used during occupied periods, cooling or heating setpoint 2 during unoccupied periods.

Each schedule consists of eight time periods set by the operator. These time periods can be flagged to be in effect or not in effect on each day of the week plus a holiday period. The day begins at 00.00 hours and ends at 23.59 hours.

Program is in unoccupied mode unless a schedule time period is in effect. If two periods overlap and are both active on the same day, the occupied mode takes priority over the unoccupied period.

Each of the eight periods can be displayed and changed with the aid of a sub-sub-menu. The table below shows how to access the period configuration. Method is the same for the time schedule #1 or the time schedule #2.

Period X configuration sub-menus (X = 1 to 8)

Item	Format	Comments
0	Period X Menu	Indicates the period (X) you are going to configure. When selected this item authorises a return to the main menu.
1	n ₁ n ₂ n ₃ n ₄ 00:00 to 23:59	Occupied period - Start time* . Authorises entering the time of day at which the occupied period starts.
2	n ₁ n ₂ n ₃ n ₄ 00:00 to 23:59	Occupied period - End time* . Authorises entering the time of day at which the occupied period ends.
3	Mo- 0 or Mo- 1	1 = the period is in effect on Monday . 0 = period not in effect on Monday
4	tu- 0 or tu- 1	1 = the period is in effect on Tuesday . 0 = period not in effect on Tuesday.
5	UE-0 or UE- 1	1 = the period is in effect on Wednesday . 0 = period not in effect on Wednesday.
6	tH- 0 or tH- 1	1 = the period is in effect on Thursday . 0 = period not in effect on Thursday.
7	Fr-0 or Fr- 1	1 = the period is in effect on Friday . 0 = period not in effect on Friday.
8	SA- 0 or SA- 1	1 = the period is in effect on Saturday . 0 = period not in effect on Saturday.
9	Su- 0 or Su- 1	1 = the period is in effect on Sunday . 0 = period not in effect on Sunday.
10	Ho- 0 or Ho- 1	1 = the period is in effect on public holidays . 0 = period not in effect on public holidays.

* n₁n₂: hours (00 to 23). The first time the Enter button is continuously pressed, the first two characters in the 4-digit display flash so that hours can be adjusted.
n₃n₄: minutes (00 to 59). Continuous pressing of the Enter key again causes the last two characters to flash so that minutes can be adjusted.

Typical timer program:

Time	MON	TUE	WES	THU	FRI	SAT	SUN	HOL
0	P1							
1	P1							
2	P1							
3								
4								
5								
6								
7	P2	P2	P3	P4	P4	P5		
8	P2	P2	P3	P4	P4	P5		
9	P2	P2	P3	P4	P4	P5		
10	P2	P2	P3	P4	P4	P5		
11	P2	P2	P3	P4	P4	P5		
12	P2	P2	P3	P4	P4			
13	P2	P2	P3	P4	P4			
14	P2	P2	P3	P4	P4			
15	P2	P2	P3	P4	P4			
16	P2	P2	P3	P4	P4			
17	P2	P2	P3					
18			P3					
19			P3					
20			P3					P6
21								
22								
23								

- MON: Monday
- TUE: Tuesday
- WED: Wednesday
- THU: Thursday
- FRI: Friday
- SAT: Saturday
- SUN: Sunday
- HOL: Public holidays

Occupied
 Unoccupied

ATTENTION: The broadcast function must be activated to utilise the holiday schedule, even if the unit is running in stand-alone mode (not connected to CCN). See section 4.3.11.8.

Holiday period X configuration sub-menus (X = 1 to 16)

Item	Format	Comments
0	HoLidAy X Sub-menu	When selected this item authorises a return to the configuration menu.
1	0 to 12	Start month of public holiday period 0 = period not in use 1 = January, 2 = February, etc.
2	0 to 31	Start day of public holiday period. 0 period not in use.
3	0 to 99 days	Duration of the public holiday period in days.

Typical programming for public holidays:

A public holiday period lasting 1 day on 20th May, for instance, is configured as follows: start month = 5, start day = 20, duration = 1

A public holiday period lasting 2 day on 25th May, for instance, is configured as follows: start month = 5, start day = 25, duration = 2

4.3.11.8 - Description of the Broadcast sub-menu (broAdCAST)

The controller provides a broadcast configuration menu which you can use to configure the unit to be the CCN's broadcaster, responsible for transmitting the time, outdoor temperature, and holiday flags to all system elements.

This menu also authorises setting the date of the daylight saving time. There should be **only one** broadcaster in a CCN, so this table should not be configured if any other system element is acting as broadcaster.

ATTENTION: If the unit operates in standalone mode (not CCN connected) this menu can also must be used if the holiday function is used or to correct for daylight saving time.

	Starts at	Ends at	Active on
P1: period 1	0h00	3h00	Monday
P2: period 2	7h00	18h00	Monday and Tuesday
P3: period 3	7h00	21h00	Wednesday
P4: period 4	7h00	17h00	Thursday and Friday
P5: period 5	7h00	12h00	Saturday
P6: period 6	20h00	21h00	Public holidays
P7: period 7	Not used in this example		
P8: period 8	Not used in this example		

4.3.11.7 - Description of the Holidays sub-menus

This function is used to define 16 public holiday periods. Each period is defined with the aid of three parameters: the month, starting day and duration of the public holiday period. During these public holidays the controller will be in occupied or unoccupied mode, depending on the programmed periods validated for public holidays.

Each of these public holiday periods can be displayed and changed with the aid of a sub-menu.

Broadcast configuration sub-menu (broAdCAST)

Item	Format	Comments
0	broAdCast MEnu	When selected this item authorises a return to the main menu.
1	YES/no	Determines whether or not the unit is a broadcast acknowledged when the unit is connected on a CCN network. There must be only one broadcast acknowledged in a CCN. Warning: if the unit operates in standalone mode (not CCN connected) this choice must be set to Yes if the holiday function is used (see section 4.3.11.6) or if you want to configure the daylight saving time function.
2	0/1/2	This item permits activation or deactivation of the broadcast mode. 0 = the controller is not the broadcaster, and it is not useful to configure another selection in this table. 1 = broadcasts time, date, holidays and the outside temperature. 2 = for chillers only. Summertime and holidays are not taken into consideration without broadcasting the information on the bus.
3	nnn	OAT Broadcaster bus number: it is the bus number of the system that has the outside air temperature sensor connected to it.
4	nnn	OAT Broadcaster element number: it is the element number of the system element that has the outside air temperature sensor connected to it.

4.3.12 - Description of the Alarms menu

This menu is used to display and reset up to 5 active alarms. It also permits alarm reset. If no alarm is active this menu is not accessible.

Alarms menu

Item	Format	Comments
0 [1]	X ALArM rESEt ALArM	X alarms are active Reset of alarms is requested.
		To reset all active alarms, continuously press the Enter key 'rESET ALArM' is then displayed. Press the select key again: all alarms are reset.
1 [1]	Alarm code text	Current alarm code 1**
2 [1]	Alarm code text	Current alarm code 2**
3 [1]	Alarm code text	Current alarm code 3**
4 [1]	Alarm code text	Current alarm code 4**
5 [1]	Alarm code text	Current alarm code 5**

[1] This item is masked when nil

* See section "Alarm codes"

** Pressing the Enter key when alarm code is displayed causes the following message to be scrolled:

"time of alarm" "date of alarm" "full CCN alarm message"

- "time of alarm": xxhmm

- "date": dd-mm

- "full CCN alarm message": up to 64 characters

4.3.13 - Description of the Alarms History menu

Alarms History menu

Item	Format	Comments
0 [1]	Alarm code text*	Alarm history code 1**
1 [1]	Alarm code text*	Alarm history code 2**
2 [1]	Alarm code text*	Alarm history code 3**
3 [1]	Alarm code text*	Alarm history code 4**
4 [1]	Alarm code text*	Alarm history code 5**
5 [1]	Alarm code text*	Alarm history code 6**
6 [1]	Alarm code text*	Alarm history code 7**
7 [1]	Alarm code text*	Alarm history code 8**
8 [1]	Alarm code text*	Alarm history code 9**
9 [1]	Alarm code text*	Alarm history code 10**
10 [1]	Alarm code text*	Alarm history code 11**
...
19 [1]	Alarm code text*	Alarm history code 20**

[1] This item is masked when nil

* See section "Alarm codes"

** Pressing the Enter key when alarm code is displayed causes the following message to be scrolled:

"time of alarm" "date of alarm" "full CCN alarm message"

- "time of alarm": xxhmm

- "date": dd-mm

- "full CCN alarm message": up to 64 characters

4.3.14 - Description of the Runtime menu

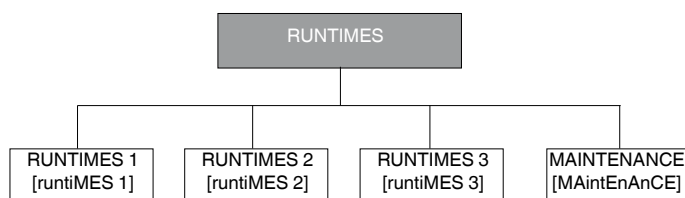

4.3.14.1 - Description of the Runtimes 1 menu

Runtimes menu [1]

Item	Format	Units	Comments
0	RuntiME 1 menu	-	When selected this item authorises return to the previous menu
1	nnnn M 10 M100	hrs/10 or 100	Unit operating hours*
2	nnnn M 10 M100	hrs/10 or 100	Compressor A1 operating hours*
3 [1]	nnnn M 10 M100	hrs/10 or 100	Compressor A2 operating hours*
4 [1]	nnnn M 10 M100	hrs/10 or 100	Compressor A3 operating hours*
5 [1]	nnnn M 10 M100	hrs/10 or 100	Compressor A4 operating hours*
6	nnnn M 10 M100	hrs/10 or 100	Compressor B1 operating hours*
7	nnnn M 10 M100	hrs/10 or 100	Compressor B2 operating hours*
8 [1]	nnnn M 10 M100	hrs/10 or 100	Compressor B3 operating hours*
9 [1]	nnnn M 10 M100	hrs/10 or 100	Compressor B4 operating hours*
10	- M 10 M100	-/10 or 100	Machine starts*
11	- M 10 M100	-/10 or 100	Compressor A1 starts*
12 [1]	- M 10 M100	-/10 or 100	Compressor A2 starts*
13 [1]	- M 10 M100	-/10 or 100	Compressor A3 starts*
14 [1]	- M 10 M100	-/10 or 100	Compressor A4 starts*
15	- M 10 M100	-/10 or 100	Compressor B1 starts*
16	- M 10 M100	-/10 or 100	Compressor B2 starts*
17 [1]	- M 10 M100	-/10 or 100	Compressor B3 starts*
18 [1]	- M 10 M100	-/10 or 100	Compressor B4 starts*

[1] This item is masked when not used

NOTES

* Certain values are divided by 10 or by 100, so that number of hours or start-ups of less than 10 are displayed as 0.

When the value is divided by 10 or by 100 it is displayed in turn with "M 10" or "M100".

4.3.14.2 - Description of Runtimes 2 menu

Runtimes menu [1]

Item	Format	Units	Comments
0	RuntiME 2 menu	-	When selected this item authorises return to the previous menu
1 [1]	nnnn M 10 M100	hrs/10 or 100	Pump 1 operating hours*
2 [1]	nnnn M 10 M100	hrs/10 or 100	Pump 2 operating hours*
3 [1]	nnnn M 10 M100	hrs/10 or 100	Heat reclaim condenser pump operating hours
4	nnnn	-	Compressor starts for compressor with most starts during the last hour
5	nnnn	-	24 hours average number of starts/hour, compressor
6 [1]	nnnn M 10 M100	hrs/10 or 100	Compressor C1 operating hours
7 [1]	nnnn M 10 M100	hrs/10 or 100	Compressor C2 operating hours
8 [1]	nnnn M 10 M100	hrs/10 or 100	Compressor C3 operating hours
9 [1]	nnnn M 10 M100	hrs/10 or 100	Compressor C4 operating hours
10 [1]	nnnn M 10 M100	-/10 or 100	Compressor C1 starts
11 [1]	nnnn M 10 M100	-/10 or 100	Compressor C2 starts
12 [1]	nnnn M 10 M100	-/10 or 100	Compressor C3 starts
13 [1]	nnnn M 10 M100	-/10 or 100	Compressor C4 starts
14 [1]	nnnn M 10 M100	-/10 or 100	No. of defrost cycles, circuit A
15 [1]	nnnn M 10 M100	-/10 or 100	No. of defrost cycles, circuit B
16 [1]	nnnn M 10 M100	-/10 or 100	Free cooling refrigerant pump operating hours, circuit A
17 [1]	nnnn M 10 M100	-/10 or 100	Free cooling refrigerant pump operating hours, circuit B
18 [1]	nnnn M 10 M100	-/10 or 100	Free cooling refrigerant pump operating hours, circuit C

[1] This item is masked when not used

4.3.14.3 - Description of the Runtimes 3 menu

Runtimes menu

Item	Format	Units	Comments
0	RuntiME 3 menu	-	When selected this item authorises return to the previous menu
1	nnnn M 10 M100	hrs/10 or 100	Fan A1 operating hours
2	nnnn M 10 M100	hrs/10 or 100	Fan A2 operating hours
3 [1]	nnnn M 10 M100	hrs/10 or 100	Fan A3 operating hours
4 [1]	nnnn M 10 M100	hrs/10 or 100	Fan A4 operating hours
5 [1]	nnnn M 10 M100	hrs/10 or 100	Fan A5 operating hours
6 [1]	nnnn M 10 M100	hrs/10 or 100	Fan A6 operating hours
7	nnnn M 10 M100	hrs/10 or 100	Fan B1 operating hours
8	nnnn M 10 M100	hrs/10 or 100	Fan B2 operating hours
9 [1]	nnnn M 10 M100	hrs/10 or 100	Fan B3 operating hours
10 [1]	nnnn M 10 M100	hrs/10 or 100	Fan B4 operating hours
11 [1]	nnnn M 10 M100	hrs/10 or 100	Fan B5 operating hours
12 [1]	nnnn M 10 M100	hrs/10 or 100	Fan B6 operating hours
13 [1]	nnnn M 10 M100	hrs/10 or 100	Fan C1 operating hours
14 [1]	nnnn M 10 M100	hrs/10 or 100	Fan C2 operating hours
15 [1]	nnnn M 10 M100	hrs/10 or 100	Fan C3 operating hours
16 [1]	nnnn M 10 M100	hrs/10 or 100	Fan C4 operating hours
17 [1]	nnnn M 10 M100	hrs/10 or 100	Fan C5 operating hours
18 [1]	nnnn M 10 M100	hrs/10 or 100	Fan C6 operating hours

[1] This item is masked when not used

4.3.14.4 - Maintenance menu description

To be active, the maintenance function must be preset in the Service configuration.

Item	Format	Description
0	MAintEnAnCE MEnu	When selected this item authorises return to the previous menu.
1 [1]	0 to 6	Deletes the maintenance alerts.
2 [1]	YES/no	Refrigerant control.
3 [1]	YES/no	Water loop rate to low
4 [1]	nnnn	Next primary pump maintenance operation in nnn days. If the number of days = 0, the delay before maintenance has elapsed.
5 [1]	nnnn	Next secondary pump maintenance operation in nnn days. If the number of days = 0, the delay before maintenance has elapsed.
6 [1]	nnnn	Next maintenance operation on the heat reclaim condenser pump. If the number of days = 0, the delay before maintenance has elapsed.
7 [1]	nnnn	Next water filter maintenance operation in nnn days. If the number of days = 0, the delay before maintenance has elapsed.

[1] This item is masked when not used.

5 - PRO-DIALOG PLUS CONTROL OPERATION

5.1 - Start/stop control

The table below summarises the unit control type and stop or go status with regard to the following parameters.

- **Operating type:** this is selected using the start/stop button on the front of the user interface.
- **Remote start/stop contacts:** these contacts are used when the unit is in remote operating type (rEM). See sections 3.6.2 and 3.6.3.
- **CHIL_S_S:** this network command relates to the chiller start/stop when the unit is in CCN control (CCn). Variable forced to disable: the unit is halted. Variable forced to Enable: the unit runs in accordance with schedule 1.

- **Start/Stop schedule:** occupied or unoccupied status of the unit as determined by the chiller start/stop program (Schedule #1).
- **Master control type.** This parameter is used when the unit is the master unit in a two chiller lead/lag arrangement. The master control type determines whether the unit is to be controlled locally, remotely or through CCN (this parameter is a Service configuration).
- **CCN emergency shutdown:** if this CCN command is activated, it shuts the unit down whatever the active operating type.
- **General alarm:** the unit is totally stopped due to failure.

Active operating type							Status of parameters					Control type	Unit mode
LOFF	L-ON	L-SC	rEM	CCN	MASt	CHIL_S_S	Remote start/stop contact	Master control type	Start/stop schedule mode	CCN emergency shutdown	General alarm		
-	-	-	-	-	-	-	-	-	-	Enable	-	-	Off
-	-	-	-	-	-	-	-	-	-	-	Yes	-	Off
Active	-	-	-	-	-	-	-	-	-	-	-	Local	Off
-	-	Active	-	-	-	-	-	-	Unoccupied	-	-	Local	Off
-	-	-	Active	-	-	-	Off	-	-	-	-	Remote	Off
-	-	-	Active	-	-	-	-	-	Unoccupied	-	-	Remote	Off
-	-	-	-	Active	-	Disable	-	-	-	-	-	CCN	Off
-	-	-	-	Active	-	-	-	-	Unoccupied	-	-	CCN	Off
-	-	-	-	-	Active	-	-	Local	Unoccupied	-	-	Local	Off
-	-	-	-	-	Active	-	Off	Remote	-	-	-	Remote	Off
-	-	-	-	-	Active	-	-	Remote	Unoccupied	-	-	Remote	Off
-	-	-	-	-	Active	Disable	-	CCN	-	-	-	CCN	Off
-	-	-	-	-	Active	-	-	CCN	Unoccupied	-	-	CCN	Off
-	Active	-	-	-	-	-	-	-	-	Disable	No	Local	On
-	-	Active	-	-	-	-	-	-	Occupied	Disable	No	Local	On
-	-	-	Active	-	-	-	On cooling	-	Occupied	Disable	No	Remote	On
-	-	-	Active	-	-	-	On heating	-	Occupied	Disable	No	Remote	On
-	-	-	Active	-	-	-	On auto	-	Occupied	Disable	No	Remote	On
-	-	-	-	Active	-	Enable	-	-	Occupied	Disable	No	CCN	On
-	-	-	-	-	Active	-	-	Local	Occupied	Disable	No	Local	On
-	-	-	-	-	Active	-	On cooling	Remote	Occupied	Disable	No	Remote	On
-	-	-	-	-	Active	-	On heating	Remote	Occupied	Disable	No	Remote	On
-	-	-	-	-	Active	-	On auto	Remote	Occupied	Disable	No	Remote	On
-	-	-	-	-	Active	Enable	-	CCN	Occupied	Disable	No	CCN	On

5.2 - Heating/cooling/standby operation

5.2.1 - General

The heating/cooling/standby selection applies to all units. But only 30RB (liquid chillers) units, controlling a boiler can change over to heating mode. Heating/cooling control can be automatic or manual.

In automatic mode the outdoor temperature determines the heating/cooling/standby changeover based on the two threshold values configured by the user (see Setpoint menu for cooling and heating mode changeover thresholds). If the unit is in standby it does not cool or heat, and no compressor can be activated. The diagram below summarises the operating principle in automatic mode.

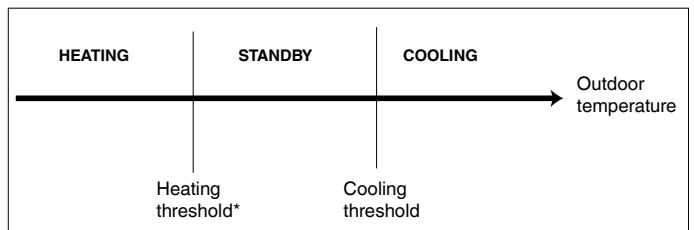

* This threshold does not apply to cooling only units that do not control a boiler.

5.2.2 - Heating/cooling/auto selection

The table below summarises the unit heating/cooling operation, based on the following parameters:

- **Control type:** indicates whether the unit operates in local, remote or CCN mode. See section 5.1.
- **Unit on/off status:** indicates whether the unit is shut down (not authorised to start) or in operation (or authorised to start).
- **Heating/cooling/auto selection in local mode:** operating mode selected via the user interface. See Information menu.

- **Remote heating/cooling contacts:** these contacts are only active if the unit is under remote control. See sections 3.6.2 and 3.6.3.
- **HC_SEL:** this network command permits heating/cooling/auto control, if the unit is in CCN operating mode.
- **Outdoor temperature:** determines the operation, if the unit is in automatic heating/cooling/standby changeover mode.

Parameter status						
On/off status	Control type	Heating/cooling selection in local mode	Remote heating/cooling contacts	HC_SEL	Outdoor temperature	Operating mode
Off	-	-	-	-	-	Cooling
On	Local	Cooling	-	-	-	Cooling
On	Local	Heating	-	-	-	Heating
On	Local	Auto	-	-	> Cooling threshold	Cooling
On	Local	Auto	-	-	< Heating threshold	Heating*
On	Local	Auto	-	-	Between cooling and heating thresholds	Standby
On	Remote	-	Cooling mode	-	-	Cooling
On	Remote	-	Heating mode	-	-	Heating
On	Remote	-	Auto mode	-	> Cooling threshold	Cooling
On	Remote	-	Auto mode	-	< Heating threshold	Heating*
On	Remote	-	Auto mode	-	Between cooling and heating thresholds	Standby
On	CCN	-	-	Cooling	-	Cooling
On	CCN	-	-	Heating	-	Heating
On	CCN	-	-	Auto	> Cooling threshold	Cooling
On	CCN	-	-	Auto	< Heating threshold	Heating*
On	CCN	-	-	Auto	Between cooling and heating thresholds	Standby

* Does not apply to cooling only units that do not control a boiler.

5.3 - Evaporator water pump control

The unit can control one or two evaporator water pumps. The evaporator water pump is turned on when this option is configured (see User configuration) and when the unit is in one of the on modes described above or in delay mode. Since the minimum value for the delay at start-up is 1 minute (configurable between 1 and 15 minutes), the pump will run for at least one minute before the first compressor starts.

The pump is kept running for 20 seconds after the unit goes to stop mode. The pump keeps working when the unit switches from heating to cooling mode or vice-versa. It is turned off if the unit is shut down due to an alarm unless the fault is a frost protection error. The pump can be started in particular operating conditions when the evaporator heater is active (see section 5.5). See section 5.14 for the particular evaporator pump control for the follower unit (master/slave assembly).

If two pumps are controlled and the reversing function has been selected (see User 1 configuration), the control tries to limit the pump run time delta to the configured pump change-over delay. If this delay has elapsed, the pump reversing function is activated, when the unit is running. During the reversing function both pumps run together for two seconds.

If a pump has failed and a secondary pump is available, the unit is stopped and started again with this pump.

The control provides a means to automatically start the pump each day at 14.00 hours for 2 seconds when the unit is off. If the unit is fitted with two pumps, the first pump is started on odd days and the second pump is started on even days. Starting the pump periodically for few seconds increases the life-time of the pump bearings and the tightness of the pump seal.

5.4 - Control interlock contact

This contact checks the status of a loop (water flow switch and customer safety loop, see section 3.6). It prevents the unit from starting if it is open when the delay at start-up has expired. This open contact leads to an alarm shut-down, if the unit is running.

5.5 - Evaporator antifreeze protection

The heater for the evaporator and water pump (for units with a pump) can be energised to protect the evaporator, if it can be damaged by freezing, when the unit is shut down for a long time at low outdoor temperature.

NOTE: Evaporator heater control parameters can be modified, using the Service configuration.

5.6 - Control point

The control point represents the water temperature that the unit must produce. The inlet water is controlled by default, but the outlet water can also be controlled (requires a Service configuration modification).

Control point = active setpoint + reset

5.6.1 - Active setpoint

Two setpoints can be selected as active in cooling mode and two in heating mode. Usually, the second cooling setpoint is used for unoccupied periods. The second setpoint in heating mode is used for unoccupied periods.

Depending on the current operations, the active setpoint can be selected by choosing the item in the Information menu, with the user's volt-free contacts, with network commands or with the setpoint timer program (schedule 2).

The following tables summarise the possible selections depending on the control types (local, remote or CCN) and the following parameters:

- **Setpoint select in local control:** item #13 of the Information menu permits selection of the active setpoint, if the unit is in local operating type.
- **Heating/cooling operating mode.**
- **Control contacts 2:** status of control contact 2.
- **Schedule 2 status:** schedule for setpoint selection.

Local operating mode

Heating/cooling operating mode	Local setpoint selection	Ice storage configuration [2]	Ice storage contact status [2]	Schedule 2 status	Active setpoint
Cooling	sp 1				Cooling setpoint 1
Cooling	sp 2				Cooling setpoint 2
Cooling [2]	Auto	Activated		Unoccupied	Ice storage setpoint
Cooling [2]	Auto	Activated	Open	Unoccupied	Cooling setpoint 2
Cooling	Auto		Closed	Occupied	Cooling setpoint 1
Cooling	Auto	Deactivated		Unoccupied	Cooling setpoint 2
Heating	sp 1				Heating setpoint 1
Heating	sp 2				Heating setpoint 2
Heating	Auto			Occupied	Heating setpoint 1
Heating	Auto			Unoccupied	Heating setpoint 2

Remote operating mode

Heating/cooling operating mode	Local setpoint selection	Ice storage configuration [2]	Ice storage contact status [2]	Control contact 2	Active setpoint
Cooling [2]	sp control				Control setpoint
Cooling				sp 1 (open)	Cooling setpoint 1
Cooling				sp 2 (closed)	Cooling setpoint 2
Cooling [2]		Activated		Open	Cooling setpoint 1
Cooling [2]		Activated	Open	Closed	Ice storage setpoint
Cooling [2]		Activated	Closed	Closed	Cooling setpoint 2
Heating				sp 1 (open)	Heating setpoint 1
Heating				sp 2 (closed)	Heating setpoint 2

Remote operating mode - dual-circuit units

Parameter status					
Heating/cooling operating mode	Ice storage configuration [2]	Ice storage contact status [2]	Schedule 2 status	Active setpoint	
Cooling			Occupied	Cooling setpoint 1	
Cooling			Unoccupied	Cooling setpoint 2	
Cooling [2]	Activated	Open	Unoccupied	Ice storage setpoint	
Cooling [2]	Activated	Closed	Unoccupied	Cooling setpoint 2	
Heating			Occupied	Heating setpoint 1	
Heating			Unoccupied	Heating setpoint 2	

[2] Only with energy management option.

5.6.2 - Reset

Reset means that the active setpoint is modified so that less machine capacity is required (in cooling mode, the setpoint is increased, in heating mode it is decreased). This modification is in general a reaction to a drop in the load. For the Pro-Dialog control system, the source of the reset can be configured in the User 1 configuration: it can be provided either by the outdoor temperature (that gives a measure of the load trends for the building) or by the return water temperature (delta T that gives an average building load) either for the reset setpoint based on a 4-20 mA input (with energy management option) or based on the room temperature, using a room temperature sensor (when the energy management option is used). In response to a drop in the outdoor temperature or to a drop in delta T, the cooling setpoint is normally reset upwards in order to optimise unit performance:

In the three cases the reset parameters, i.e. slope, source and maximum value, are configurable in the Setpoints menu (see section 4.3.8). Reset is a linear function based on three parameters.

- A reference at which reset is zero (outdoor temperature or delta T - no reset value).
- A reference at which reset is maximum (outdoor temperature or delta T - full reset value).
- The maximum reset value.

Reset example in cooling mode based on the outside temperature

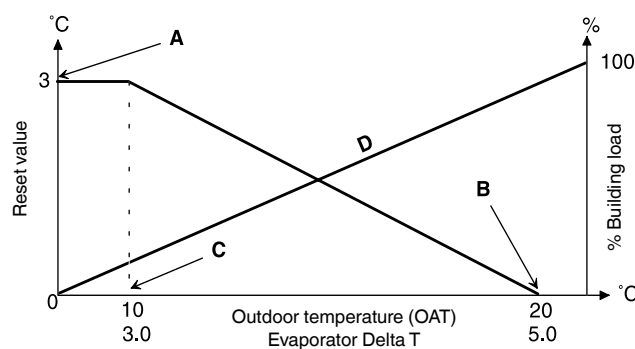

Legend

- A Maximum reset value
- B OAT or delta T for full reset
- C OAT or delta T for no reset
- D Building Load

5.7 - Demand limit

The demand limit is used to restrict the unit power consumption. The Pro-Dialog control system allows limitation of the unit capacity, using one of two methods:

- by means of user-controlled volt-free contacts. The units without energy management option only have one demand limit level (only one contact: control contact 3). The units equipped with energy management option permit three demand limit levels (2 contacts). The unit capacity can never exceed the limit setpoint activated by these contacts. The limit setpoints can be modified in the setpoint menu.
- by means of a 4-20 mA input type on the energy management board. The limit is now based on a linear interpolation from 0 to 100%, based on the input signal. The demand limit in night mode is selectable (if the value is below the one controlled by the external signal).

5.8 - Night mode

The night period is defined (see User configuration) by a start time and an end time that are the same for each day of the week. During the night period, the number of fans operating can be reduced, and the unit capacity may be limited (but a minimum capacity value can be configured).

5.9 - Capacity control

This function adjusts the number of active compressors to keep the heat exchanger water temperature at its setpoint. The precision with which this is achieved depends on the capacity of the water loop, the flow rate, the load, and the number of stages available on the unit. The control system continuously takes account of the temperature error with respect to the setpoint, as well as the rate of change in this error and the difference between entering and leaving water temperatures, in order to determine the optimum moment at which to add or withdraw a capacity stage. If the same compressor undergoes too many starts (per hour) or runs below one minute each time it is started this automatically brings about reduction of compressor starts, which makes leaving water temperature control less precise. In addition, the high pressure, low pressure or defrost unloading functions can also affect the temperature control accuracy. Compressors are started and stopped in a sequence designed to equalise the number of start-ups (value weighted by their operating time).

5.10 - Head pressure control

The head pressure is controlled by a maximum of six fans. As an option, a variable-speed controller can control one or all of the fans. The head pressure is independently controlled for each circuit, based on the saturated condensing temperature value.

Fan start-up:

ATTENTION: The fans can be started periodically (for cleaning), even if the unit is switched off.

5.11 - Defrost function

Defrost is activated, when the unit is in heating mode, in order to reduce frost build-up on the air heat exchanger. The defrost cycle can only be applied to one circuit at a time. During the defrost cycle the fans of that circuit are stopped, and the four-way refrigerant valve is reversed, forcing the circuit to cooling mode. The fan can temporarily be restarted during the defrost cycle. The defrost cycle is fully automatic and does not require any setting.

5.12 - Additional electric heater stage control

The heat pump units can control up to four additional electric heating stages.

The electric heating stages are activated to complement the heating capacity when the following conditions are satisfied:

- The unit uses 100% of the available heating capacity, or the unit is limited in its operation by a protection mode (low suction temperature, hot gas or defrost sequence in progress protection), and in all cases cannot satisfy the heating load.
- The outdoor temperature is below a configured threshold (see User 1 configuration).
- The unit demand limit is not active.

The user may configure the last available electric heating stages as a safety stage. In this case, the safety stage is only activated in addition to the other stages if there is a machine fault, preventing the use of the heating capacity. The other electric heating stages will continue to operate as described above.

5.13 - Control of a boiler

NOTE: The control of the electric heating stages or of a boiler is not authorised for slave units.

The unit can control the start-up of a boiler, if it is in heating mode. When the boiler is operating, the unit water pump is stopped.

A heat pump unit and a boiler cannot operate together. In this case the boiler output is activated in the following conditions:

- The unit is in heating mode, but a fault prevents the use of the heat pump capacity.
- The unit is in heating mode, but works at a very low outdoor temperature, making the heat pump capacity insufficient. The outdoor air temperature threshold for use of the boiler is fixed at -10°C , but this value can be adjusted in the User 1 menu.

5.14 - Master/slave assembly

Two PRO-DIALOG Plus units can be linked to produce a master/slave assembly. The two machines are interconnected over the CCN bus. All parameters required for the master/slave function must be configured through the Service configuration menu. Master/slave operation requires the connection of a temperature probe at the common manifold on each machine, if the heat exchanger leaving water temperature is controlled.

The master/slave assembly can operate with constant or variable flow. In the case of variable flow each machine must control its own water pump and automatically shut down the pump, if the cooling capacity is zero. For constant flow operation the pumps for each unit are continuously operating, if the system is operating. The master unit can control a common pump that will be activated, when the system is started. In this case the slave unit pump is not used.

All control commands to the master/slave assembly (start/stop, setpoint, heating/cooling operation, load shedding, etc.) are handled by the unit which is configured as the master, and must therefore only be applied to the master unit. They will be transmitted automatically to the slave unit. The master unit can be controlled locally, remotely or by CCN com-ands. Therefore to start up the assembly, simply validate the Master operating type (MASt) on the master unit. If the Master has been configured for remote control then use the remote volt-free contacts for unit start/stop. The slave unit must stay in CCN operating type continuously. To stop the master/slave assembly, select Local Off (LOFF) on the master unit or use the remote volt-free contacts if the unit has been configured for remote control.

One of the functions of the master unit (depending on its configuration) may be the designation, whether the master or slave is to be the lead machine or the follower. The roles of lead machine and follower will be reversed when the difference in running hours between the two units exceeds a configurable value, ensuring that the running times of the two units are automatically equalised. The changeover between lead machine and follower may take place when the assembly is started up, or even whilst running. The running time balancing function is not active if it has not been configured: in this case the lead machine is always the master unit.

The lead machine will always be started first. When the lead machine is at its full available capacity, start-up delay (configurable) is initialised on the follower. When this delay has expired, and if the error on the control point is greater than 1.7°C, the follower unit is authorised to start and the pump is activated. The follower will automatically use the master unit active setpoint. The lead machine will be held at its full available capacity for as long as the active capacity on the follower is not zero. When the follower unit receives a command to stop, its evaporator water pump is turned off with 20 seconds delay.

In the event of a communication fault between the two units, each shall return to an autonomous operating mode until the fault is cleared. If the master unit is halted due to an alarm, the slave unit is authorised to start without prior conditions.

ATTENTION: For heat pumps operating in master/slave mode and with leaving water temperature control the first AUX2 fan board must be replaced by the AUX1 board and connected to a common temperature sensor.

5.15 - Optional heat reclaim module

This option requires the installation of an additional board.

This board allows control of:

- A heat reclaim condenser pump,
- A heat reclaim condenser heater,
- Two solenoid valves to shut off the heat reclaim coil (one for each circuit),
- Two solenoid drain valves for the heat reclaim coil (one for each circuit),
- Two solenoid valves to shut off the water condenser (one for each circuit),
- Two solenoid drain valves for the water condenser (one for each circuit).

Selecting the heat reclaim mode can be done with either the local interface or remotely with the (recl_sw) contact or by CCN.

The heat reclaim function is active when: the heat reclaim entering water temperature is lower than the heat reclaim setpoint, minus half of the heat reclaim dead band.

The heat reclaim function is not active when: the heat reclaim entering water temperature is higher than the heat reclaim setpoint, plus half of the heat reclaim dead band.

In the dead band the function remains in its active mode. The default value of the dead band is 4.4 K. This value can be modified by Carrier Service.

Changeover procedure from cooling to heat reclaim mode:

- Start-up of the condenser pump.
- Verification of the condenser flow switch control contact. If this remains open after one minute of condenser pump operation, the circuit remains in cooling mode and an alarm will be activated.
- As soon as the saturated condensing temperature reaches 30°C, the pumpdown sequence is activated.
- Pumpdown: opening of the condenser water inlet valve and closing of the air condenser air valves 3 seconds later.
- After one minute or when the subcooling value is above -10°C the heat reclaim function is effective.

5.16 - Free-cooling option

The direct-expansion free-cooling principle is to circulate the liquid refrigerant with a pump and to condense it to a lower temperature at the condenser when the outside temperature is low (below the setpoint). The performance achieved is huge, as only a pump and fans are activated.

This option requires the installation of an additional board for each circuit. These boards allow control of:

- a three-way compressor shut-off valve
- a refrigerant pump.

The following sensors are connected to each board:

- a pump suction pressure sensor
- a pump discharge pressure sensor
- a potentiometer to copy the position of the three-way valve.

The prevention or authorisation of free cooling mode operation can be controlled by the local interface or remotely by customer contact 4 or by the CCN network.

If pre-cooling is prohibited, free cooling starts if:

- the outside temperature is lower than the programmed threshold value (USER2 menu, item 15)
- the difference between outside temperature and control point is higher than the minimum operating threshold value (4°C)

If pre-cooling is authorised, free cooling starts if:

- the outside temperature is lower than the programmed threshold value (USER2 menu, item 15)
- the difference between outside temperature and leaving water temperature is higher than the minimum operating threshold value (4°C)

To stop the free cooling, a hysteresis of 0.5 K has been applied to these temperatures. When free cooling is stopped, a new session is prohibited for one hour.

Free cooling change-over procedure:

- The compressors stop (if the unit was operating)
- The high/low pressure is equalised by opening the EXV
- The three-way valve receives the command to open

Procedure to start up one circuit in free cooling:

- Wait for the complete opening of the three-way valve
- Draw a vacuum and transfer the residual compressor charge to the free-cooling circuit by starting up a compressor (“pump-down”),
- Start up the fans
- Cycle the pump (rotation for 10 seconds, shut-down for 4 seconds)
- Verify that a differential pressure is established at the pump terminals.

During free cooling operation all fans are activated except when the differential between the outside temperature and the leaving water temperature reaches a certain threshold value. In this case only half of the fans are energised.

Expansion valve (EXV) control is based on the difference between the outside temperature and the leaving water temperature to prevent disengaging or cavitation of the refrigerant pump.

The same pump stability logic can activate a pump-down cycle, based on the pressure level detected in the compressors at shut-down (up to three times in a free-cooling cycle) to make the full refrigerant charge in the free-cooling circuit available.

6 - DIAGNOSTICS - TROUBLESHOOTING

6.1 - General

The Pro-Dialog Plus control system has many fault tracing aid functions. The local interface and its various menus give access to all unit operating conditions. If an operating fault is detected, an alarm is activated and an alarm code is stored in the Alarm menu.

6.2 - Displaying alarms

The alarm LEDs on the summary interface (see section 4.1) give a quick display of the status of each circuit and the unit as a whole.

- A flashing LED shows that the circuit is operating but there is an alarm.
- A steady LED shows that the circuit has been shut down due to a fault.









The Alarm menu on the main interface displays up to 5 fault codes that are active on the unit.

6.3 - Resetting alarms

When the cause of the alarm has been corrected the alarm can be reset, depending on the type, either automatically on return to normal, or manually when action has been taken on the unit. Alarms can be reset even if the unit is running.

This means that an alarm can be reset without stopping the machine. In the event of a power supply interrupt, the unit restarts automatically without the need for an external command. However, any faults active when the supply is interrupted are saved and may in certain cases prevent a circuit or a unit from restarting.

A manual reset must be run from the main interface using the following procedure:

Reset of active alarms				
Operation	Item number 2-digit display	Item value 4-digit display	Press button	Menu LED
Hold down the MENU button until the LED for alarms lights. The 4-digit display shows the number of active alarms (2 in this example).	0			
Press the Enter button until “rESEt ALARm” is shown in the 4-digit display.	0	2 ALARm		
Press the Enter button again to validate the reset. “Good” is displayed for 2 seconds then, “2 ALARm” and then, “no ALARm”.	0	rESEt ALARm		
		Good then, 2 AL then, no ALARm		

6.4 - Alarm codes

The following list gives a complete description of each alarm code and its possible cause.

Alarm code descriptions				
Alarm code	Alarm description	Reset type	Probable cause	Action taken by the control
Thermistor faults				
th-01	Sensor fault, fluid entering water heat exchanger	Automatic when the temperature measured by the sensor returns to normal	Defective thermistor	Unit is shut down
th-02	Sensor fault, fluid leaving water heat exchanger	As above	As above	As above
th-03	Defrost fault, circuit A	As above	As above	Circuit is shut down, if the unit is in heating mode
th-04	Defrost fault, circuit B	As above	As above	As above
th-08	Heat reclaim condenser inlet sensor fault	As above	As above	The heat reclaim mode is stopped
th-09	Heat reclaim condenser outlet sensor fault	As above	As above	As above
th-10	Outside temperature sensor fault	As above	As above	Unit is shut down
th-11	CHWS fluid sensor fault (master/slave)	As above	As above	The master/slave mode is stopped
th-12	Suction sensor fault, circuit A	As above	As above	Circuit is shut down
th-13	Suction sensor fault, circuit B	As above	As above	As above
th-14	Suction sensor fault, circuit C	As above	As above	As above
th-18	Condenser subcooling liquid sensor fault, circuit A	As above	As above	The heat reclaim mode of the circuit is stopped
th-19	Condenser subcooling liquid sensor fault, circuit B	As above	As above	As above
th-21	Room temperature sensor fault	As above	As above	Set-point control by the thermostat is stopped
Pressure transducers				
Pr-01	Discharge pressure transducer fault, circuit A	Automatic when the voltage transmitted by the sensor returns to normal	Defective transducer or installation fault	Circuit is shut down
Pr-02	Discharge pressure transducer fault, circuit B	As above	As above	As above
Pr-03	Discharge pressure transducer fault, circuit C	As above	As above	As above
Pr-04	Suction pressure transducer fault, circuit A	As above	As above	As above
Pr-05	Suction pressure transducer fault, circuit B	As above	As above	As above
Pr-06	Suction pressure transducer fault, circuit C	As above	As above	As above
Pr-07	Heat reclaim pressure sensor, circuit A	As above	As above	The heat reclaim mode is stopped
Pr-08	Heat reclaim pressure sensor, circuit B	As above	As above	As above
Pr-16	Suction pressure sensor, free cooling refrigerant pump, circuit A	As above	As above	The free cooling mode is stopped
Pr-17	Discharge pressure sensor, free cooling refrigerant pump, circuit A	As above	As above	As above
Pr-18	Suction pressure sensor, free cooling refrigerant pump, circuit B	As above	As above	As above
Pr-19	Discharge pressure sensor, free cooling refrigerant pump, circuit B	As above	As above	As above
Pr-20	Suction pressure sensor, free cooling refrigerant pump, circuit C	As above	As above	As above
Pr-21	Discharge pressure sensor, free cooling refrigerant pump, circuit C	As above	As above	As above
Communication with slave boards				
Co-a1	Communication loss with compressor A1 board	Automatic when communication is re-established	Installation bus fault or defective slave board	Compressor is shut down
Co-a2	Communication loss with compressor A2 board	As above	As above	As above
Co-a3	Communication loss with compressor A3 board	As above	As above	As above
Co-a4	Communication loss with compressor A4 board	As above	As above	As above
Co-b1	Communication loss with compressor B1 board	As above	As above	As above
Co-b2	Communication loss with compressor B2 board	As above	As above	As above
Co-b3	Communication loss with compressor B3 board	As above	As above	As above
Co-b4	Communication loss with compressor B4 board	As above	As above	As above
Co-c1	Communication loss with compressor C1 board	As above	As above	As above
Co-c2	Communication loss with compressor C2 board	As above	As above	As above
Co-c3	Communication loss with compressor C3 board	As above	As above	As above
Co-c4	Communication loss with compressor C4 board	As above	As above	As above
Co-e1	Communication loss with EXV No. 1 board	As above	As above	Circuits A and B are shut down
Co-e2	Communication loss with EXV No. 2 board	As above	As above	Circuit C is shut down
Co-f1	Communication loss with fan No. 1 board	As above	As above	Circuit A is shut down (on certain units also circuit B)
Co-f2	Communication loss with fan No. 2 board	As above	As above	Circuit B is shut down
Co-f3	Communication loss with fan No. 3 board	As above	As above	Circuit C is shut down
Co-02	Communication loss with electric heater board	As above	As above	Electric heater control is stopped
Co-03	Communication loss with energy management board NRCP2	As above	As above	The EMM accessory functions are stopped
Co-04	Communication loss with heat recovery board NRCP2	As above	As above	Unit is shut down
Co-05	Communication loss with the AUX1 free-cooling board of circuit A	Automatic, when the communication is re-established	Bus installation fault or slave board faulty	Circuit A is shut down
Co-06	Communication loss with the AUX1 free-cooling board of circuit B	As above	As above	Circuit B is shut down
Co-07	Communication loss with the AUX1 free-cooling board of circuit C	As above	As above	Circuit C is shut down

Alarm code descriptions (continued)

Alarm code	Alarm description	Reset type	Probable cause	Action taken by the control
Process faults				
P-01	Water heat exchanger frost protection	Automatic if the same alarm has not tripped during the last 24 hours, otherwise manual	Water flow rate to low or defective thermistor	Unit is shut down
P-05	Low suction temperature, circuit A	Automatic when the temperature returns to normal, and if this alarm has not appeared during the last 24 hours, otherwise manual	Pressure sensor defective, EXV blocked or low refrigerant charge	Circuit is shut down
P-06	Low suction temperature, circuit B	As above	As above	As above
P-07	Low suction temperature, circuit C	As above	As above	As above
P-08	High superheat, circuit A	As above	As above If free-cooling option is used: 3-way valve position incorrect	As above
P-09	High superheat, circuit B	As above	As above	As above
P-10	High superheat, circuit C	As above	As above	As above
P-11	Low superheat, circuit A	As above	As above If free-cooling option is used: 3-way valve position incorrect	As above
P-12	Low superheat, circuit B	As above	As above	As above
P-13	Low superheat, circuit C	As above	As above	As above
P-14	Water flow control and customer interlock fault	Automatic if the unit is in manual shut-down status, otherwise manual	Evaporator pump defect or water flow switch fault	Unit is shut down
P-15	Condenser water flow controller fault	Manual	Sensor defective	The heat reclaim mode is stopped
P-16	Compressor A1 not started or no pressure increase	Manual	Connection problem	Compressor is shut down
P-17	Compressor A2 not started or no pressure increase	Manual	Connection problem	As above
P-18	Compressor A3 not started or no pressure increase	Manual	Connection problem	As above
P-19	Compressor A4 not started or no pressure increase	Manual	Connection problem	As above
P-20	Compressor B1 not started or no pressure increase	Manual	Connection problem	As above
P-21	Compressor B2 not started or no pressure increase	Manual	Connection problem	As above
P-22	Compressor B3 not started or no pressure increase	Manual	Connection problem	As above
P-23	Compressor B4 not started or no pressure increase	Manual	Connection problem	As above
P-24	Compressor C1 not started or no pressure increase	Manual	Connection problem	As above
P-25	Compressor C2 not started or no pressure increase	Manual	Connection problem	As above
P-26	Compressor C3 not started or no pressure increase	Manual	Connection problem	As above
P-27	Compressor C4 not started or no pressure increase	Manual	Connection problem	As above
P-28	Control box thermostat or phase reversal detected	Automatic when the contact closes again	Control box badly ventilated or poor electrical connection	Unit is shut down
P-29	Communication loss with the System Manager	Automatic when communication is re-established	CCN installation bus defective	Unit goes into autonomous mode
P-30	Communication loss between master and slave	Automatic when communication is re-established	CCN installation bus defective	As above
MC-nn	Master chiller No. 1 configuration error at nn	Automatic when the master configuration returns to normal or when the unit is no longer in master/slave mode	Master/slave configuration error	Master/slave mode is stopped
FC-n0	No factory configuration	Automatic when the configuration is entered	The unit size has not been configured	Unit is shut down
FC-01	Illegal factory configuration number	Manual	The unit size has been configured with the wrong value	As above
P-31	CCN emergency stop	Manual	Network command	As above
P-32	Fault water pump 1	Manual	Pump overheating or poor pump connection	Unit is completely stopped if there is no emergency pump
P-33	Fault water pump 2	Manual	Pump overheating or poor pump connection	As above
P-34	Reclaim operation failure, circuit A	Manual	Sensor defective or low condenser water flow rate	The heat reclaim mode of the circuit is stopped
P-35	Reclaim operation failure, circuit B	Manual	Sensor defective or low condenser water flow rate	As above
P-37	Repeated high pressure unloading, circuit A	Automatic	Transducer defective or ventilation circuit fault	None
P-38	Repeated high pressure unloading, circuit B	Automatic	As above	As above
P-39	Repeated high pressure unloading, circuit C	Automatic	As above	As above
P-40	Repeated low suction temperature unloading in heating mode, circuit A	Manual	Pressure sensor defective or refrigerant charge too low	Circuit is shut down
P-41	Repeated low suction temperature unloading in heating mode, circuit B	Manual	As above	As above
P-42	Repeated low suction temperature unloading, circuit C	Manual	As above	As above
P-43	Heat exchanger temperature too low, less than 10°C, prevents unit start-up	Automatic when the temperature detected returns to normal or when the mode returns to cooling	Operating compressor protection out of range or pressure sensor fault	The unit cannot start

Alarm code descriptions				
Alarm code	Alarm description	Reset type	Probable cause	Action taken by the control
Process faults (cont'd)				
P-91	Position of the free cooling 3-way valve incorrect for circuit A	Manual	The valve has not reached the expected position in the time assigned	Unit is shut down
P-92	Position of the free cooling 3-way valve incorrect for circuit B	As above	As above	As above
P-93	Position of the free cooling 3-way valve incorrect for circuit C	As above	As above	As above
P-94	Operating fault in free cooling, circuit A	Automatic, if the unit switches back to normal cooling mode	The refrigerant pump has not correctly started or has cavitated	The free cooling mode of the circuit is stopped
P-95	Operating fault in free cooling, circuit B	As above	As above	As above
P-96	Operating fault in free cooling, circuit C	As above	As above	As above
P-97	Reversed entering/leaving water sensors	Manual	Sensor defective, sensors reversed	Unit is stopped
CT-01	Fault, contactor stuck, circuit A	Manual	A compressor contactor is stuck, the compressor cannot shut down	Ventilation and EXV control are maintained. A second critical fault can result in the shut down of the ventilation, closure of the EXV and destruction of the compressor
CT-02	Fault, contactor stuck, circuit B	As above	As above	As above
CT-03	Fault, contactor stuck, circuit C	As above	As above	As above
V0-xx	Fault, variable speed controller, circuit A	Manual or automatic	Speed controller fault or alert	The circuit continues to operate, the speed controller slows down the motor. The circuit shuts down
V1-xx	Fault, variable speed controller, circuit B	As above	As above	As above
V2-xx	Fault, variable speed controller, circuit C	As above	As above	As above
Maintenance alarms				
A1-01	Maintenance alert, service number nn	Manual	The preventive maintenance date has passed	
Compressor faults				
A1-01	Fault, compressor A1 N°1	See compressor alarm subcode		
A1-nn	Fault, compressor A1 N°nn	See compressor alarm subcode		
A2-01	Fault, compressor A2 N°1	See compressor alarm subcode		
A2-nn	Fault, compressor A2 N°nn	See compressor alarm subcode		
A3-01	Fault, compressor A3 N°1	See compressor alarm subcode		
A3-nn	Fault, compressor A3 N°nn	See compressor alarm subcode		
A4-01	Fault, compressor A4 N°1	See compressor alarm subcode		
A4-nn	Fault, compressor A4 N°nn	See compressor alarm subcode		
B1-01	Fault, compressor B1 N°1	See compressor alarm subcode		
B1-nn	Fault, compressor B1 N°nn	See compressor alarm subcode		
B2-01	Fault, compressor B2 N°1	See compressor alarm subcode		
B2-nn	Fault, compressor B2 N°nn	See compressor alarm subcode		
B3-01	Fault, compressor B3 N°1	See compressor alarm subcode		
B3-nn	Fault, compressor B3 N°nn	See compressor alarm subcode		
B4-01	Fault, compressor B4 N°1	See compressor alarm subcode		
B4-nn	Fault, compressor B4 N°nn	See compressor alarm subcode		
C1-01	Fault, compressor C1 N°1	See compressor alarm subcode		
C1-nn	Fault, compressor C1 N°nn	See compressor alarm subcode		
C2-01	Fault, compressor C2 N°1	See compressor alarm subcode		
C2-nn	Fault, compressor C2 N°nn	See compressor alarm subcode		
C3-01	Fault, compressor C3 N°1	See compressor alarm subcode		
C3-nn	Fault, compressor C3 N°nn	See compressor alarm subcode		
C4-01	Fault, compressor C4 N°1	See compressor alarm subcode		
C4-nn	Fault, compressor C4 N°nn	See compressor alarm subcode		
Process faults				
XX-01*	Compressor B1 motor temperature too high	Manual	Motor fault, wiring	The compressor is shut down
XX-02*	Compressor B1 crankcase heater fault	Manual	Crankcase heater defective, wiring fault	As above
XX-03*	Compressor B1 high pressure switch fault	Manual	Condenser flow rate too low, condenser valve blocked, fan circuit fault, condenser air or water entering temperature too high	As above
XX-04*	PTC temperature probe Compressor motor B1 out of range	Manual	Probe defective	As above
XX-05	Compressor board power supply is disconnected	Automatic	Unstable system voltage, system power supply unavailable	Compressor is shut down
XX-06	Compressor board and contactor power supply drop	Automatic	Unstable system voltage, system power supply unavailable	Compressor is shut down to avoid damage to the contactors

* XX-04 = A1 to A4, B1 to B4 and C1 to C4

