

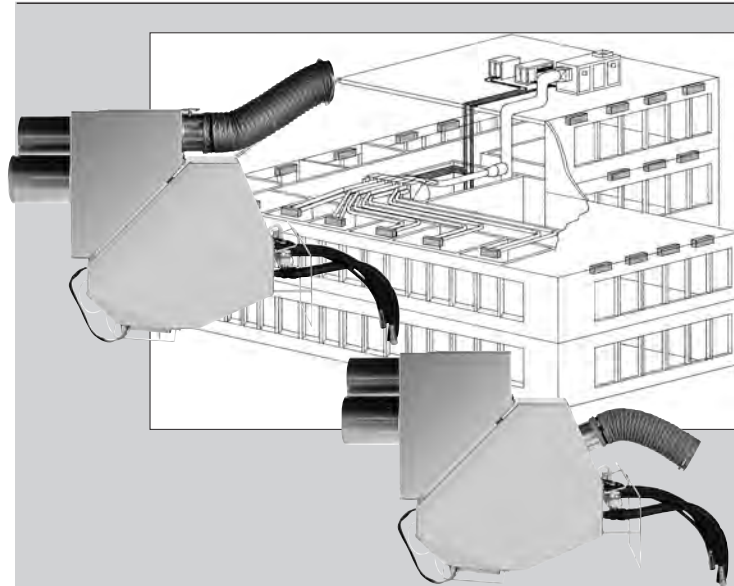

United Technologies

## 42GR ATM



**EN**

**AIR TREATMENT MODULE  
Installation instructions**

**FR**

**MODULE DE TRAITEMENT DE L'AIR  
Manuel d'installation**

**DE**

**Installationanweisungen**

**IT**

**Manuale d'installazione**

**NL**

**Montagehandleiding**

**RU**

**Инструкции по установке**



Quality and Environment  
Management Systems  
Approval

**ENGLISH****CONTENTS**

<b>1 - PRECAUTIONS .....</b>	<b>11</b>
1.1 – Operating limits .....	11
1.2 – Reservation for maintenance .....	11
1.3 – Reception – Place of installation .....	11
1.4 – Supply voltage 230 V ± 10% - 50 Hz .....	11
<b>2 – SAFETY CONSIDERATIONS .....</b>	<b>11</b>
2.1 – General points .....	11
2.2 – Protection against electrocution .....	12
2.3 – General recommendations for installation .....	12
2.4 – Recommendation regarding the regulation .....	12
2.5 – Compliance .....	12
<b>3 – INSTALLATION OF THE UNIT .....</b>	<b>13</b>
3.1 – Procedure for installation .....	13
3.2 – Connection of fresh air .....	14
3.3 – Procedure for dismantling the ATM .....	14
<b>4 - COMPONENTS .....</b>	<b>14</b>
4.1 – Fan motors LEC .....	14
4.2 – Optional electric battery .....	15
4.3 – Water coils .....	16
4.4 – Optional air filter and access .....	16
4.5 – Fresh air flow regulator .....	16
4.6 – Water flow regulation valves .....	9
4.7 – Hydraulic hose option .....	17
<b>5 – CODING .....</b>	<b>18</b>

**FRANCAIS****TABLE DES MATIÈRES****DEUTSCH****INHALT****ITALIANO****INDICE****NEDERLANDS****INHOUD****РУССКИЙ****СОДЕРЖАНИЕ**

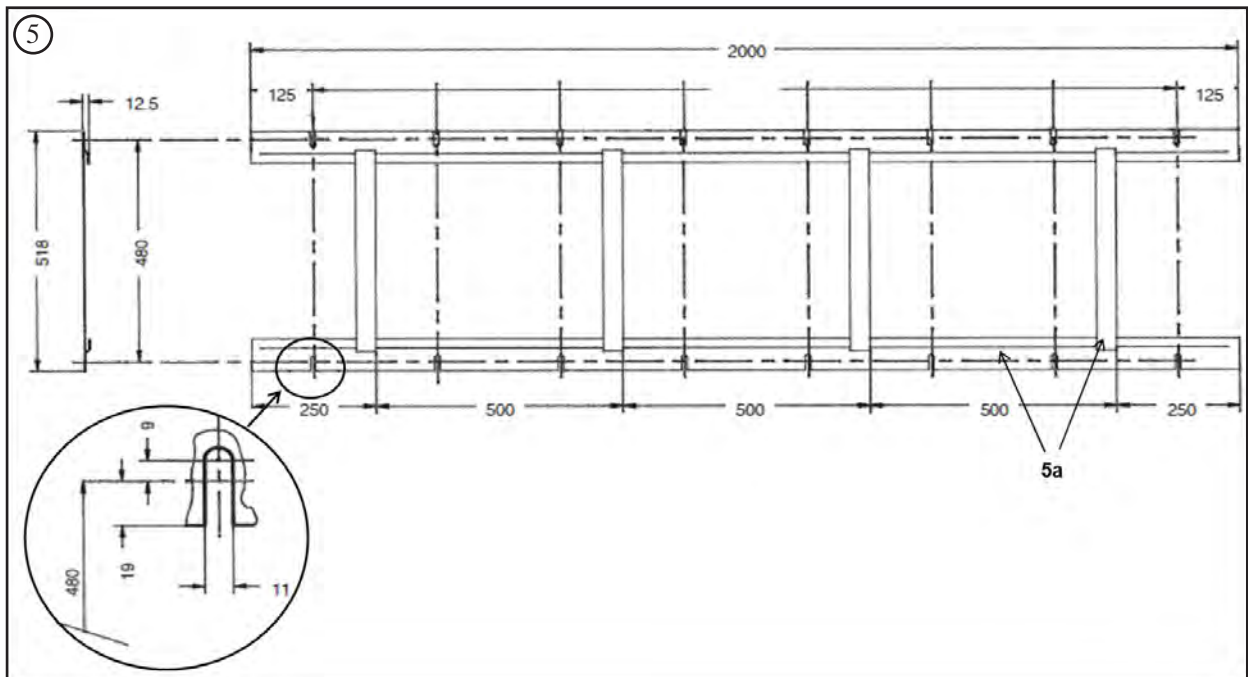
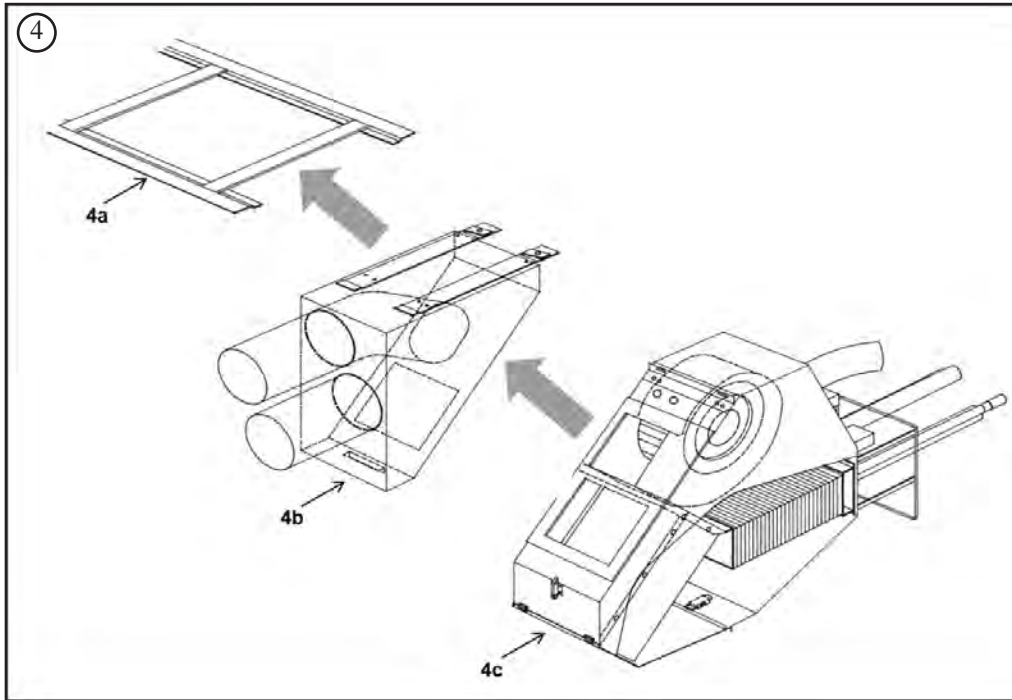
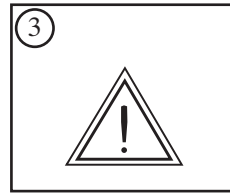
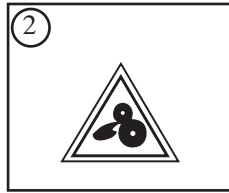
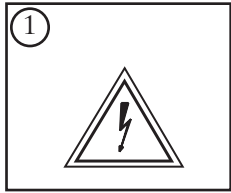

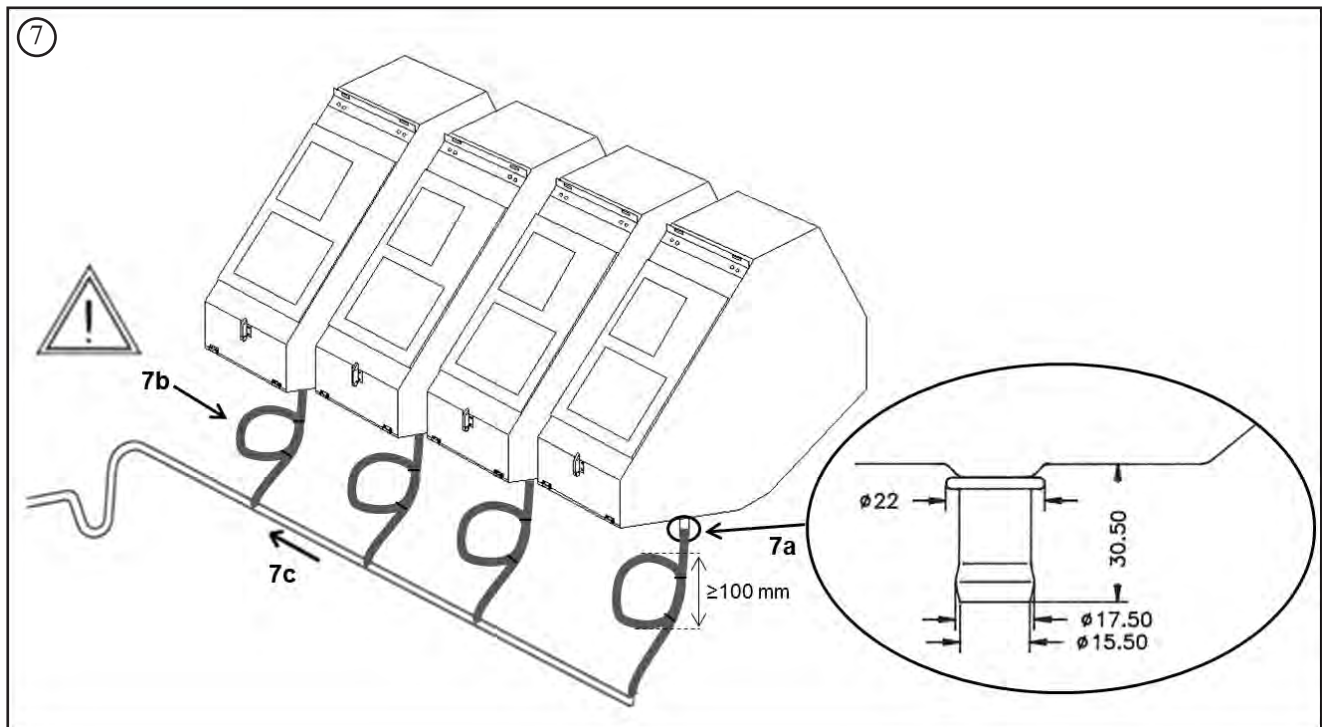
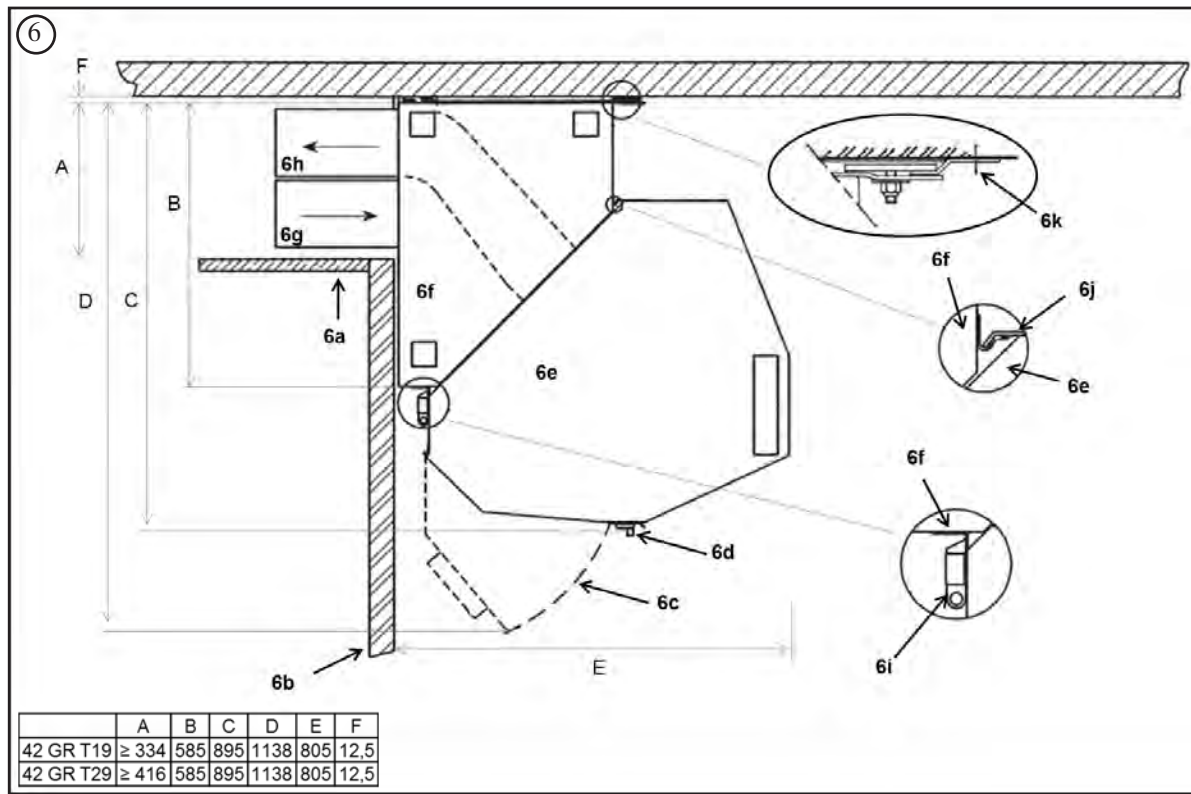

8

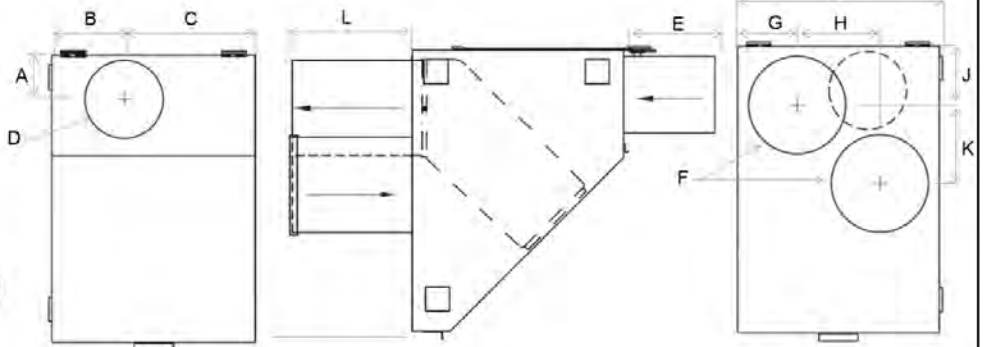
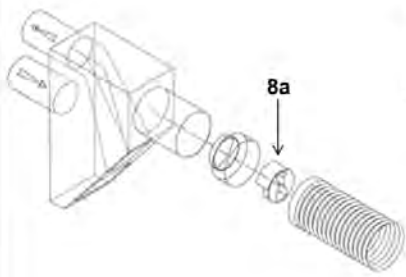

	A	B	C	D	E	F	G	H	I	J	K	L
42 GR T19	90	107	137	159	190	159	93	58	250	93	177	250
42 GR T29	90	147	267	159	190	199	122	170	420	120	160	250

9

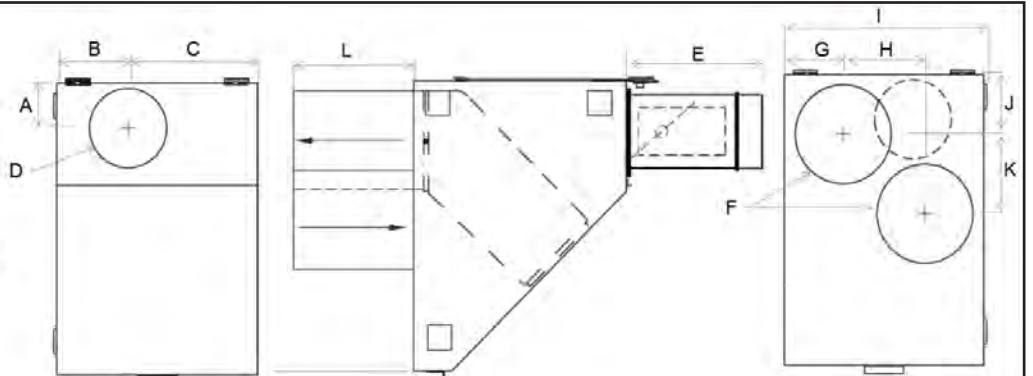
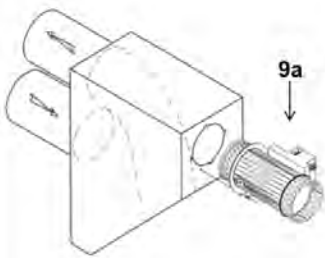

	A	B	C	D	E	F	G	H	I	J	K	L
42 GR T19	90	107	137	125	230	159	93	58	250	93	177	250
42 GR T29	90	147	267	125	230	199	122	170	420	120	160	250

10

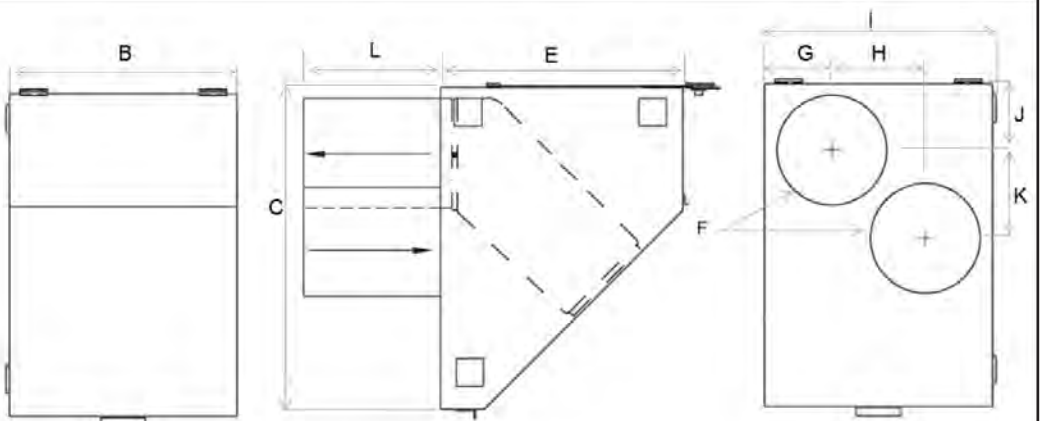
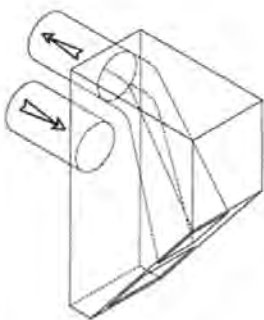

	B	C	E	F	G	H	I	J	K	L
42 GR T19	244	585	440	159	93	58	250	93	177	250
42 GR T29	414	585	440	199	122	170	420	120	160	250

11

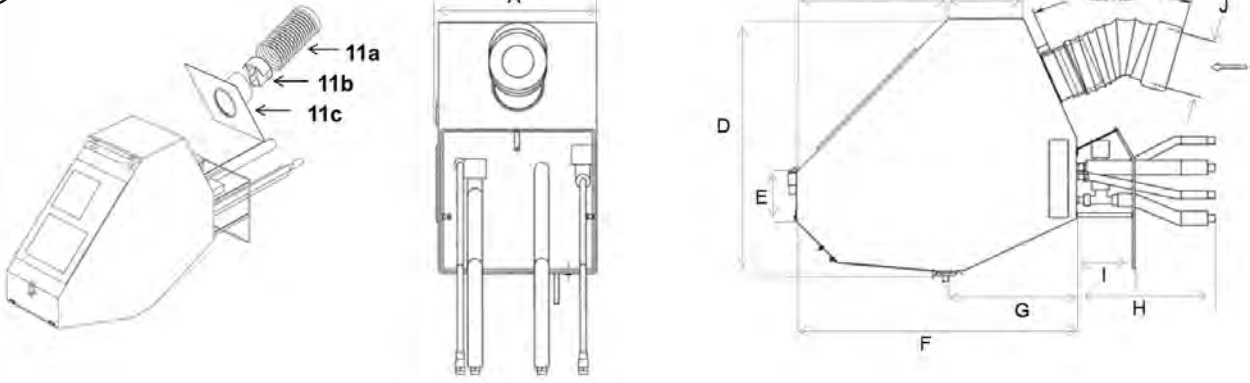

	A	B	C	D	E	F	G	H	I	J
42 GR T19	250	402	198	674	128	742	344	≤ 600	183	75 -125
42 GR T29	420	402	198	674	128	742	344	≤ 600	183	75 -125

12

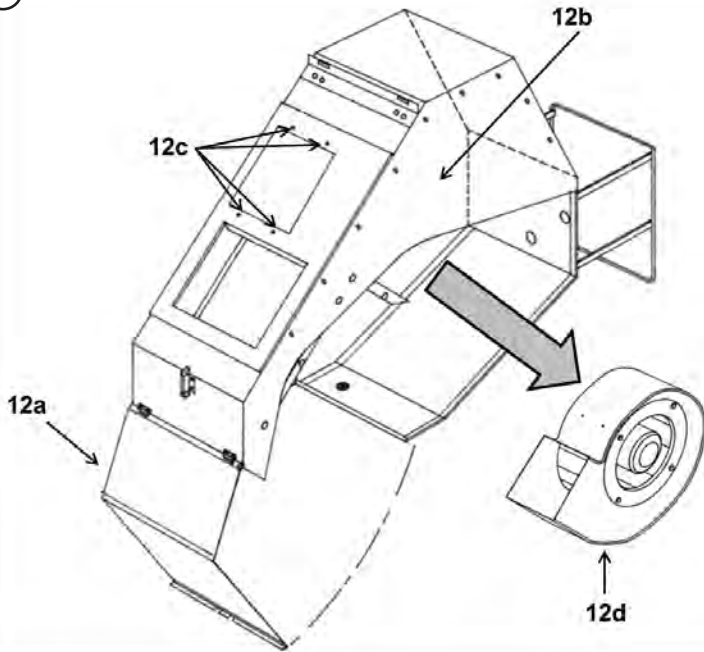

13

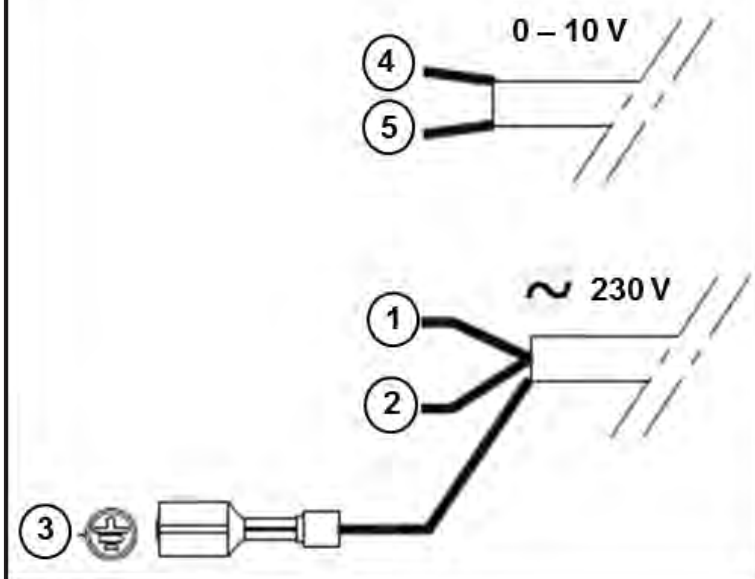

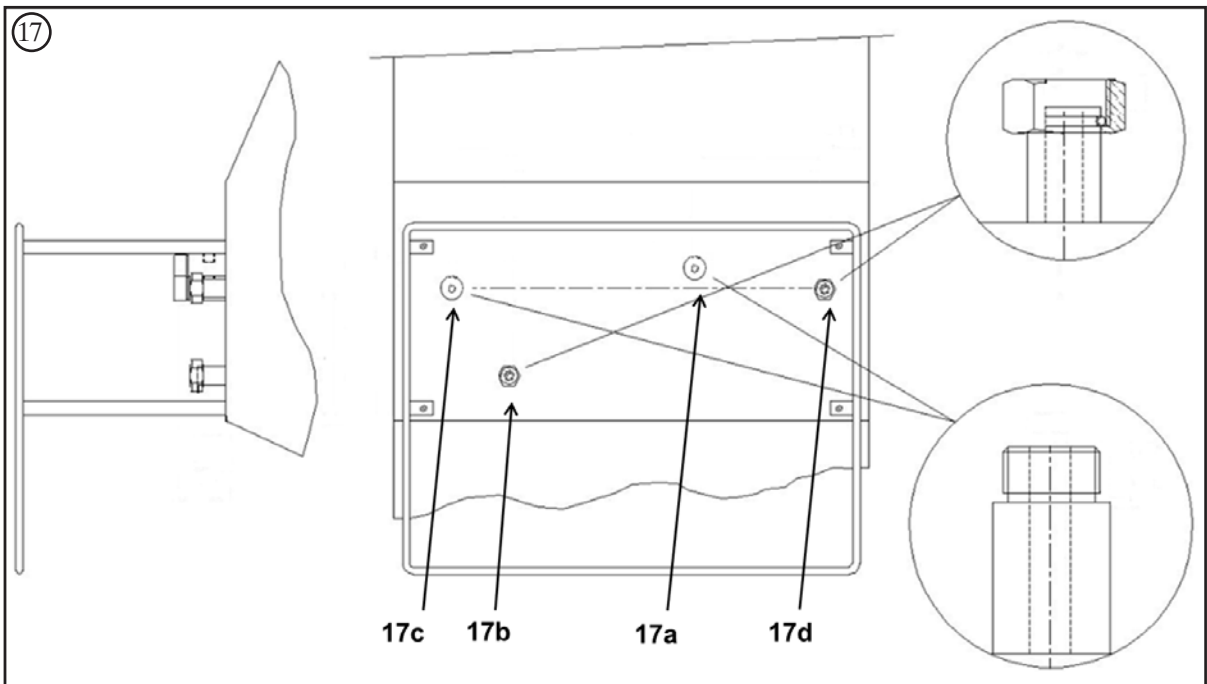
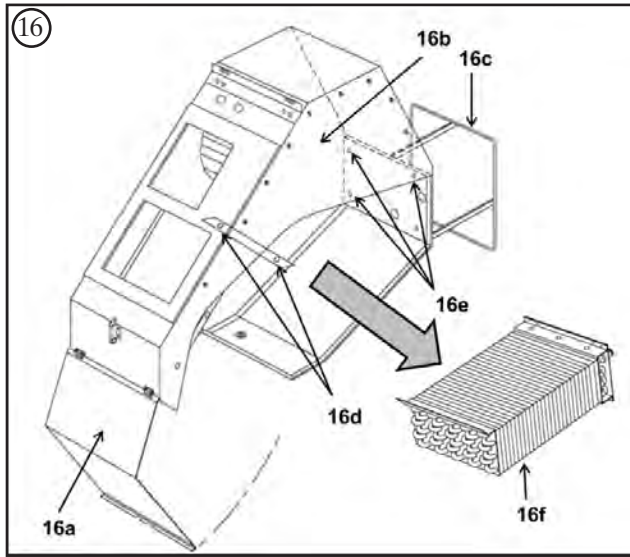
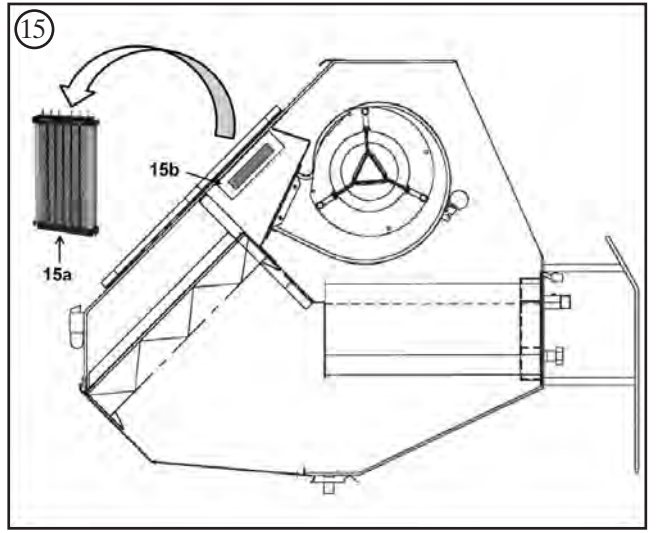
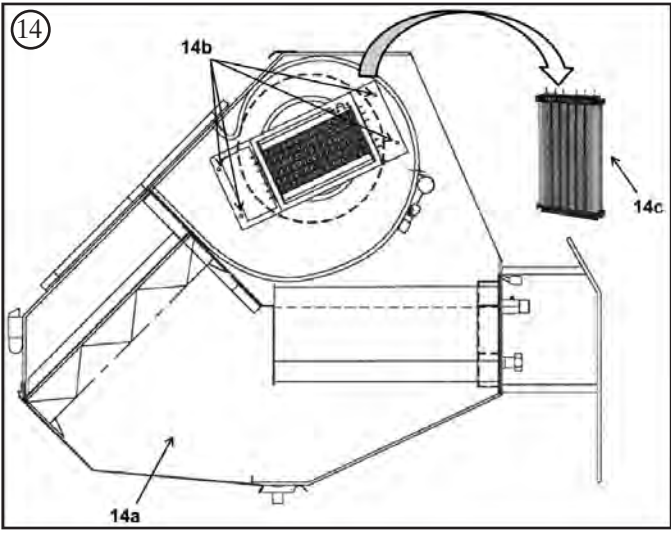

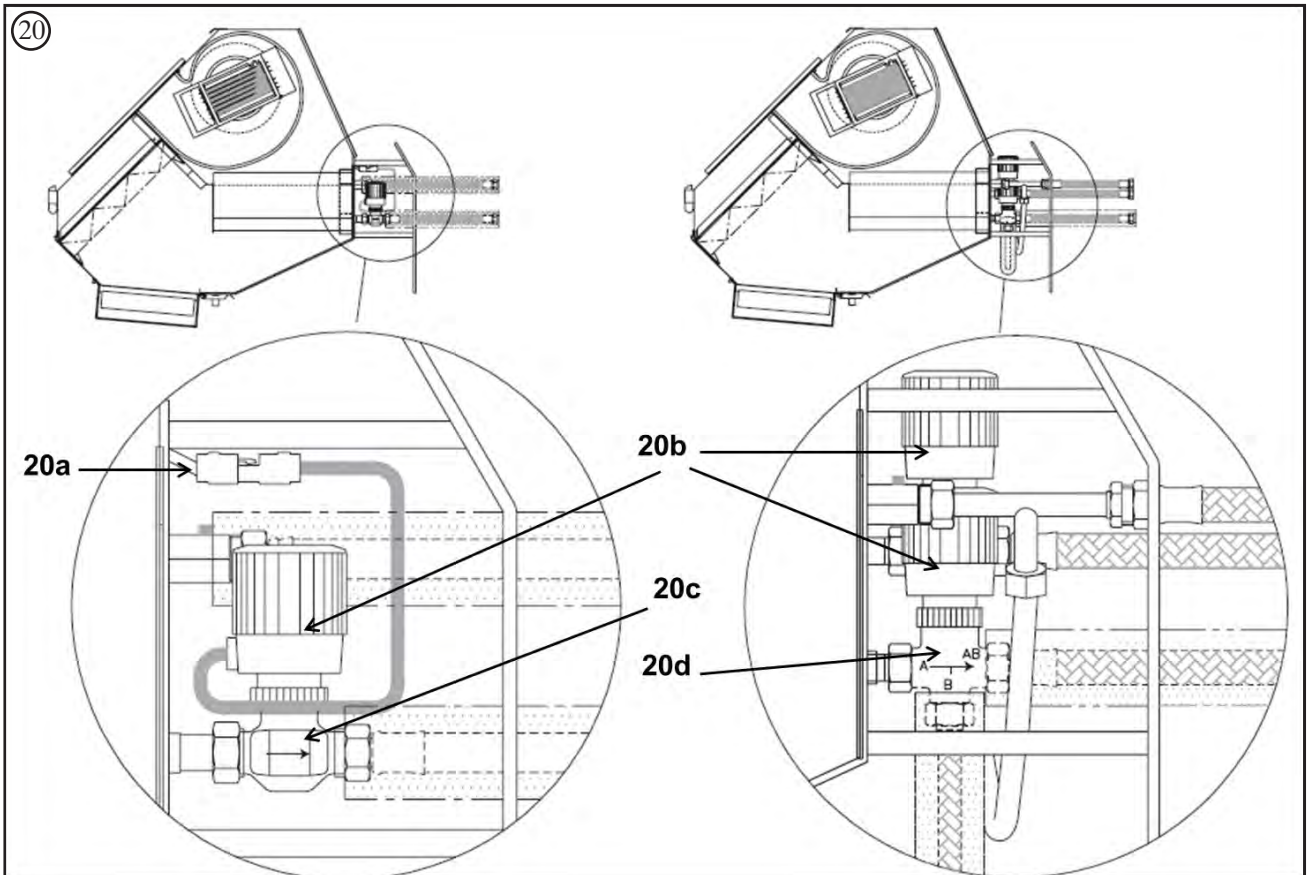
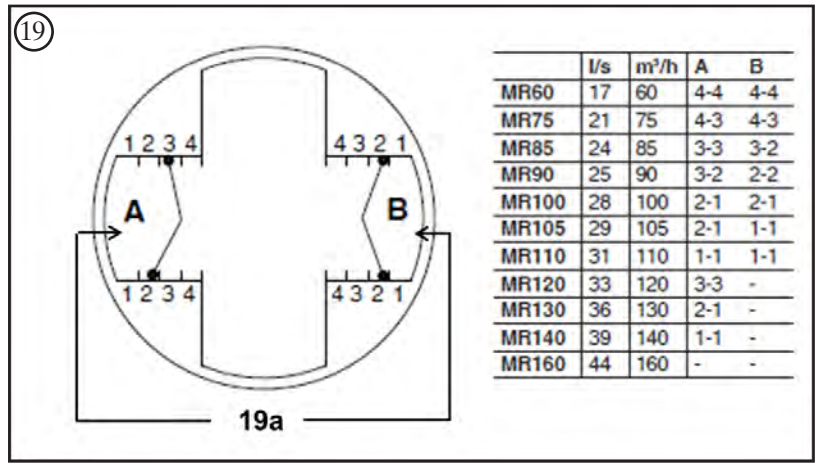
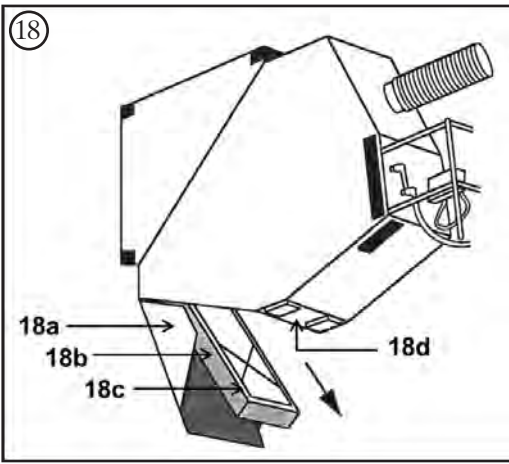



**Figure titles and legends:**

- 1 "Electrical danger" Pictograph
- 2 "Be careful with your hands" Pictograph
- 3 "General Danger" Pictograph
- 4 General overview of unit assembly
  - 4a Attachment rail
  - 4b Suspension box
  - 4c Air treatment module
- 5 Attachment rail drawing, mm
  - 5a Attachment rail
- 6 Suspension box and ATM assembly, mm
  - 6a False ceiling
  - 6b Partition for technical room
  - 6c Filter access door (open position)
  - 6d Drainage of condensates
  - 6e Air treatment module
  - 6f Suspension box
  - 6g Ferrule for recirculation
  - 6h Ferrule for blowing
  - 6i Fastening hook
  - 6j Suspension hook
  - 6k Fixing on concrete slab
- 7 Connection for drainage of condensates, mm
  - 7a Nozzle for flexible tube inner ø 16 mm
  - 7b 100 mm Siphon or Yoke on the drainage pipe
  - 7c Slope of 20 mm/m
- 8 Constant fresh air flow suspension box, mm (optional)
- 9 Variable fresh air suspension box, mm (optional)
- 10 Standard suspension box, mm
- 11 ATM with fresh water supply, mm (optional)
  - 11a Flexible duct for fresh air (optional)
  - 11b Constant fresh air flow regulator (optional)
  - 11c Fan access door
- 12 Dismantling of fan motor
  - 12a Fan access door
  - 12b Side panel fixed with Torx T20 screws
  - 12c Torx T20 screws fixing the fan
  - 12d Fan motor
- 13 LEC vitesse variable - wires nus
  - 1 Phase 230 V – brown wire
  - 2 Neutral 230 V – blue wire
  - 3 Earthing – green and yellow wire
  - 4 0 – 10 V – yellow wire
  - 5 GND – blue wire
- 14 Replacement of the electric battery (42GR Size 19)
  - 14a Side panel fixed with Torx T20 screws
  - 14b Electrical battery support fixed with screws (optional)
  - 14c Electrical battery (optional)
- 15 Replacement of the electric battery (42GR Size 29)
  - 15a Electrical battery (optional)
  - 15b Electrical battery support fixed with screws (optional)
- 16 Dismantling of water battery
  - 16a Fan access door
  - 16b Side panel fixed with Torx T20 screws
  - 16c Valve housing fixed with Torx T20 screws (optional)
  - 16d Torx T20 rear fixing screws
  - 16e Torx T20 front fixing screws
  - 16e Water battery
- 17 Water battery inlets/ outlets
  - 17a Inlet (2 tubes) or Cold water inlet (4 tubes, optional)
  - 17b Outlet (2 tubes) or Cold water outlet (4 tubes, optional)
  - 17c Hot water inlet (4 tubes, optional)
  - 17d Hot water outlet (4 tubes, optional)
- 18 Replacement of the filter
  - 18a Filter access door
  - 18b Filter (optional)
  - 18c Joint on filter edge
  - 18c Fastening latch
- 19 Adjustable constant fresh air flow regulator (optional)
  - 19a Restrictions for passage of air
- 20 Replacement of the servomotors and valve body
  - 20a Quick power connector
  - 20b Servomotors (optional)
  - 20c Valve body (2 channels) (optional)
  - 20d Valve body (3 channels) (optional)

**Figures et légendes:****Abbildungen und Legende:**

**ITALIANO**

Titoli e Legenda delle Figure:

**NEDERLANDS**

Titels van afbeeldingen en verklaringen:

**РУССКИЙ**

Заголовки рисунков и легенды к ним:

## 1 - PRECAUTIONS

### 1.1 - Operating limits

#### 1.1.1 - Cooling mode

Minimum blowing temperature 12°C when the apparatus is installed in an atmosphere of 27°C DB (dry bulb) and 65% RH (relative humidity).

#### 1.1.2 - Heating mode

The blowing temperature must not exceed 60°C. Carrier recommends not to exceed a temperature of 35°C for blowing so as to avoid any risk of layering, cause of discomfort.

#### 1.1.3 - Operating environment

42GR ATM has been designed to operate in a non-corrosive, "urban" internal atmosphere, free of dust, in a non-marine environment. The levels of the chemical compounds below must in no case be exceeded:

- SO<sub>2</sub> < 0.02 ppm
- H<sub>2</sub>S < 0.02 ppm
- NO, NO<sub>2</sub> < 1 ppm
- NH<sub>3</sub> < 6 ppm
- N<sub>2</sub>O < 0.25 ppm

Do not install the unit in atmospheres comprising inflammable gases, or acidic or alkaline products. The copper/ aluminium battery and the internal components could undergo irreversible corrosion.

#### 1.1.4 - Quality of water recommended for the water coils

On receiving the installation, and then periodically every year, it is recommended to carry out a bacteriological (detection of ferro-bacteria, H<sub>2</sub>S producing bacteria and sulfate reducing bacteria) and chemical analysis of water (in order to avoid the problems of scaling and corrosion). The water circuit must include components required for the treatment of water: filters, additives, intermediate exchangers, purges, vents, isolating valves, etc. depending on the results of the analysis.

The results of analysis must correspond to the values mentioned below:

- Total hardness in mmol/l 1 < mmol/l < 1.5
- Chlorides Cl<sup>-</sup> < 10 mg/l
- Sulfates [SO<sub>4</sub><sup>2-</sup>] < 30 mg/l
- Nitrates [NO<sub>3</sub><sup>-</sup>] = 0 mg/l
- Dissolved iron < 0,5 mg/l
- Dissolved Oxygen 4 < [O<sub>2</sub>] < 9 mg/l
- Carbon dioxide [CO<sub>2</sub>] < 30 mg/l
- Resistivity 20 Ω·m < Resistivity < 50 Ω·m
- pH 6.9 < pH < 8

### 1.2 - Reservation for maintenance

42GR ATM requires some place to carry out its maintenance. Changing the filter is done through the filter access door (Fig. 6c) of the air treatment module (ATM).

### 1.3 - Reception – Place of installation

Upon reception, check the condition of the equipment, identify any possible damage owing to transportation and send any complaint regarding this to the transporter in writing. Do not unpack until the final installation, as close as possible to the place of installation, and do not place heavy tools on the packaging during the waiting period.

#### 1.4 - Supply voltage 230 V ± 10% - 50 Hz

Check whether the supply voltage and frequency correspond to those required for the unit to be installed.

**CAUTION: Carrier suspends the effect of the warranty if these points are not followed, or if electrical changes have been made to the original connections.**

## 2 - SAFETY CONSIDERATIONS

**NOTE: Before any intervention on the unit, cut the main power supply to the unit and any accessories.**

### 2.1 - General points

The installation, commissioning and maintenance operations of the various components of the system (unit, control system, hot water, cold water, ventilation networks) can be dangerous if certain factors specific to the installation are not considered such as the presence of mains voltage and the presence of hot or cold water in the air treatment equipment. Only specially trained and qualified installers and technicians, having received in-depth training on the product concerned, are authorized to install, commission and maintain this equipment.

During any intervention, all the recommendations and instructions which are mentioned in the maintenance manuals, on the labels or in the instructions accompanying the entire equipment, as well as all the other safety instructions applicable should be applied.

Definition of the pictograms used:

- Electrical danger: Fig. 1
- Be careful with your hands: Fig. 2
- General danger: Fig. 3

Follow all the safety regulations and codes in force. Wear safety glasses and protective gloves. Handle the equipment with care during handling and installation operations.

### 2.2 - Protection against electrocution

Only qualified personnel within the meaning of the recommendations of the CEI 364 standard (International Electro technical Commission) equivalent to Europe HD 384, France NFC 15 100 or UK IEE Wiring Regulation, must have access to the electrical components. It is especially mandatory to cut all the power supplies to the unit before any intervention. Cut the main power supply using the disconnecting device (not supplied by Carrier).

**IMPORTANT:** The components constituting the various control systems provided, include electronic items. As such, they can generate electromagnetic disturbances or be disrupted if they are not installed or operated in accordance with the instructions herein. The components constituting these control systems are in accordance with the requirements for electromagnetic compatibility for residential, commercial and light industry. They are also in accordance with the low voltage guidelines.

When the product is delivered without Carrier regulator, verification of EMC compliance is the responsibility of the integrator.

### 2.3 - General recommendations for installation

**IMPORTANT:** The regulators must have an upstream disconnecting device (double pole circuit breaker, for instance). In case of necessity, an accessible emergency stop device (lightning protection switch, for instance) must enable switching off of all the devices. They must be dimensioned and installed according to the CEI 364 recommendation equivalent to Europe HD 384, France NFC 15 100 or UK IEE Wiring Regulation. These devices are not supplied by Carrier.

In general, the following rules must be observed:

Upstream protection against surges	
Unit without electric battery	T2A
Unit with electric battery	T16A

- The devices must include upstream protection against current leakage to earth (GFCI circuit breaker not supplied by Carrier). Caution, the current leakage from the motor of the unit is 0.27 mA with operating voltage 230 V AC.
- Clear marking must be done on the disconnecting device in order to correctly identify the devices connected to it.
- Cabling for components constituting the various control systems and the communication bus must be done in accordance with the rules of the art by professional installers.
- The supply cable must be provided with double insulation and held by the anti-traction jumper provided for this purpose, or the cable clamp supplied with the Carrier digital controller. The supply cable must be maintained with the double insulation.
- The components constituting these various control systems must be installed in an environment in accordance with their protection index (PI).
- The maximum pollution level is normally polluting (level 2) and the category of installation II.
- Low voltage cabling (Communication Bus) must be physically separated from the power cabling.
- In order to avoid interference with the connecting cables:
  - Separate the low voltage cables from the power cables, avoid using the same cable route (maximum 300 mm common with the 230 V AC, 30 A cable).
  - Do not pass the low voltage cables into power cable loops.
  - Do not connect heavy inductive loads to the same power source (circuit breaker) used to supply the regulator equipment or power modules.
  - Use the screened type of cable recommended by Carrier and maintain the cables connected to the regulators and power modules.

### 2.4 - Recommendation regarding the regulation

**IMPORTANT:** It is not allowed to connect several 42GR ATM to the same control element (wall-mounted thermostat, NTC electronic regulator, etc...)

### 2.5 - Compliance

This equipment has been deemed compliant with the essential requirements of the following guidelines:

- Electromagnetic compatibility: 2004/108/EEC,
- Low-voltage guidelines: 2006/95/EEC.

## 3 - INSTALLATION OF THE UNIT

### 3.1 - Procedure for installation

#### 3.1.1 - Introduction

42GR ATMs are designed to be installed in a technical service room in the centre of the space to be treated. They are arranged side by side and their very high pressure provided enables them to operate with large duct networks.

42GR ATMs are composed of 3 main components to be installed in the following order (Fig.4):

- The attachment rail: Fig.4a
- The suspension box: Fig.4b
- The air treatment module (ATM): Fig.4c

The assembly instructions for each component are explained below.

#### 3.1.2 – Attachment rail

**Fix the attachment rail** firmly into the concrete slab overhanging the technical room. The attachment rail drawing is detailed in Fig.5. It makes it possible to receive the suspension box for the support of the ATM. It is supplied as packages of 5 rails of two metres. The assembly makes it possible to suspend 40 size 1 or 23 size 2 ATMs. The rails can be cut to the required length.

#### 3.1.3 – Suspension box

**CAUTION:** The suspension boxes cannot be dismantled at all, once they are installed, sheathed and if the false ceiling of the technical rooms is closed.

**PRECAUTIONS FOR INSTALLATION:** During installation of the unit, ensure that any construction debris which has remained in the ducts cannot damage the unit.

- **Attach the suspension box** to the attachment rail in order to support the ATM and to ensure the bulkhead connection of the technical room (Fig.6b). The suspension box comprises an uninsulated plenum consisting of ferrules, one for the air recirculated (Fig.6g) and one for the air blown (Fig.6h). In accordance with the mandatory requirements for sound levels, silencers may be provided.
- **Complete the ventilation connections** for the suspension box (blowing and recirculation of air). Ensure that the insides of the ducts are clean to avoid the movement of construction debris which could damage the mechanical parts of the system such as the fan turbine or the thermostat component of the diffuser.

**CAUTION: Load losses in the ducts must be compatible with the performance of the device. The duct must be as taut as possible. Avoid sharp bends. Check that the ducts have no air leaks and that they are not overburdened.**

- **Prepare the hydraulic system** with installation of collectors and stop valves in standby position on the various spurs. Sufficient clearance will have been provided for the assembly and dismantling of the ATMs as well as for maintenance of the filters through the filter access door (Fig.6c).

### 3.1.4 – Air treatment module (ATM)

**CAUTION: Never lift the ATM by using exposed pipes, valves/ hoses, electrical wiring harnesses, or condensate drains.**

- **Fix the ATM to the suspension box.** For this, it must be attached to the suspension hook (Fig.6j); then push the ATM against the box. This will cause crushing of the seal located between the box and the ATM and locking of the latch hook (Fig.6i). Then connect the hydraulic hoses.
- **Connect the condensate drains of the ATM** (Fig.7) using a fastener for flexible tube of inner  $\varnothing$  16 mm (Fig.7a). To avoid the emergence of odour, it is MANDATORY to install a siphon of at least 100 mm on each ATM (for example yoke with the condensate drainage tube) (Fig.7b). Make a slope of 20mm/m on the common drain pipe (Fig.7c) without blip or lifting.
- **Connect the hydraulic hoses** between the stop valves of the collectors and the water inlet(s)/ outlet(s) of the 42GR ATM (Carrier recommends the use of hydraulic hoses which can be supplied as accessories). Each hose is provided with a G1/2” rotating nut depending on the model. Do not forget to insert a seal between the rotating nut and the stop valve (seal not supplied by Carrier).
- When all the units are installed, open the stop valves located on the collectors, purge the circuits, and then pressurize. To purge the coils: slightly loosen the vent screws. The installation can then operate.

**NOTE: Do not turn on unless all the 42GR ATM are connected and earthed.**

## 3.2 – Connection of fresh air

Fresh air (optional) can be connected either to the suspension box or to the ATM depending on the adjustment selected.

### 3.2.1 – Fresh air to suspension box

#### 3.2.1.1 – Case of the constant fresh air flow suspension box (Fig.8)

This multipurpose box is provided to receive the regulators for constant fresh air flow (See 4.5.1 – Regulator for constant fresh air flow). The use of this box enables the treatment of fresh air through the battery and the filter of the ATM.

This box is provided with a ferrule for connection and a flexible duct of maximum length 700 mm  $\varnothing$  160 mm.

#### 3.2.1.2 – Case of the variable fresh air flow suspension box (Fig.9)

The use of this box enables the treatment of fresh air through the battery of the ATM. This fresh air flow can be adjusted using the Carrier regulator (See 4.5.2 – Regulator for variable fresh air flow).

This box is provided with duct connection. Carrier recommends the installation of a semi-rigid circular cross-section duct of 250 mm length and a minimum static pressure of 180 Pa upstream of the fresh air flow regulator.

#### 3.2.1.3 – Case of the standard suspension box (Fig.10)

In this adjustment, the box does not have a fresh air inlet. However, fresh air intake can be ensured through the air treatment module (ATM) (See 3.2.2 – Fresh air in ATM).

### 3.2.2 – Fresh air in ATM (Fig.11)

Fresh air is connected to the ATM through the fan access door (Fig.11c). Three adjustments of the fresh air flow are possible:

- Only ferrule for connection  $\varnothing$  125 mm (without fresh air flow regulator), air duct provided.
- Ferrule for connection with fixed constant fresh air flow regulator (See 4.5.1.1 – Fixed constant fresh air flow regulator). This latter is inserted into a flexible duct of maximum length 450 mm  $\varnothing$  75 mm.
- Ferrule for connection with adjustable constant fresh air flow regulator (See 4.5.1.2 – Adjustable constant fresh air flow regulator). This latter is inserted into a flexible duct of maximum length 450 mm  $\varnothing$  125 mm.

**NOTE: Each duct is provided with a clamp facilitating the mounting of the latter on the manifold of the main supply.**

## 3.3 – Procedure for dismantling the ATM (Fig. 6)

Cut the power supply to the apparatus, from the circuit breaker (not supplied by Carrier) provided for this purpose during installation.

- Disconnect the electrical power supply cables.
- Close the hydraulic valves located on the collectors.
- Disconnect the hydraulic hoses on the collectors side by unscrewing the G 1/2” rotating nuts.

**CAUTION: The hydraulic hoses not being provided with check valves, provide a container making it possible to drain the battery.**

- Disconnect the condensate drain pipes.
- Disconnect the fresh air supply in the case where it is fixed to the ATM (See 3.2.2 – Fresh air in ATM).
- Pull out the latch hook (Fig.6i) to unlock the attachment from the ATM.
- Gently lift the ATM to release it from its suspension hook (Fig.6j) located on the upper part of the ATM. Move back the ATM by about 10 mm to remove it from its support.
- Install the ATM on the edge of the non-removable plate side.
- Proceed with reassembly of the ATM by applying the reverse procedure.

## 4 - COMPONENTS

### 4.1 – Fan motors LEC

#### 4.1.1 - Procedure for dismantling of the fan motor (Fig. 12)

**CAUTION:** Before any intervention on this product, it is imperative to cut the power supply to the unit.

In the case of malfunctioning of the fan motor, the complete assembly of the fan motor must be dismantled and replaced:

- Unhook the ATM from its suspension support by following the procedure indicated (See 3.3 – Procedure for dismantling of the ATM).
- Open the filter access door (Fig. 12a).
- Unscrew and then remove the side plate (Fig.12.b) of the ATM fixed with Torx T20 star screws (side opposite to the non-removable plate).
- Disconnect the power supply cables of the fan motor (quick power and control connectors).
- The fan motor is fixed to the unit with Torx T20 star screws, unscrew these screws from the outside. (Fig.12c).
- Remove the fan motor (Fig.12d) from the side of the removed plate.
- Replace the fan motor and proceed with reassembly by applying the procedure in reverse order.

**NOTE:** Be careful not to touch the turbines while dismantling the fan motor, balancing may be adversely affected.

- In the case of an optional electric battery:  
On 42GR ATM Size 19: the electric battery is located in the suction eye of the fan motor. Unscrew the electric battery support in order to isolate the fan motor.  
On 42GR ATM Size 29: the electric battery is placed in the discharge suction eye of the fan motor. Mark the number of components connected to the electric battery, and then disconnect these electric wires as well as the quick power supply connector from the electric battery. Do not let the wires touch each other. Then, lift the electric battery from its support from the outside in order to reach the fixing screws of the fan motor.
- Remove the fan motor (Fig.12d) from the side of the removed plate.
- Replace the fan motor and proceed with reassembly by applying the procedure in the reverse order.

#### 4.1.2 – Fan cabling

##### 4.1.2.1 - Variable speed LEC – naked wires

See Fig.13.

##### 4.1.2.2 - Variable speed LEC – NTC regulator (optional)

The electrical connection to a 230 V AC supply of the fan motor as well as that of the 0-10V DC control signal are made in the factory in the NTC regulator.

**CAUTION:** For the supply of the NTC, the connection of the various inlets / outlets and the adjustment of the regulator: refer to the installation and operation manual of the NTC.

### 4.2 - Optional electric battery

**CAUTION:** Before any intervention, it is imperative to cut the electrical power supply of the unit.

In the case of malfunctioning of the electric battery the latter must be replaced. This replacement procedure is slightly different depending on the size of the 42GR ATM: Size 19 or 29.

**IMPORTANT:** When the electric battery is powered, do not touch the metallic components which are turned on.

#### 4.2.1- Procedure for replacement of the electric battery – 42GR ATM Size 19 (Fig. 14)

For the Size 19 42GR ATM, the electric battery is located in the suction eye of the fan motor.

**CAUTION:** Before any intervention on this product, it is imperative to cut the electrical power supply of the unit.

- Unhook the ATM from its suspension support by following the procedure indicated (See 3.3 – Procedure for dismantling the ATM).
- Open the filter access door (Fig. 12a).
- Unscrew and then remove the side plate of the ATM fixed with Torx T20 star screws (side opposite to the non-removable plate) (Fig.14a).
- Mark the number of components connected to the electric battery, and then disconnect these electric wires as well as the quick power supply connector from the electric battery. Do not let the wires touch each other.
- Unscrew the fixing screws from the electric battery support (Fig.14b).
- Remove the electric battery (Fig. 14c) from its support.
- Replace the electric battery and proceed with reassembly by applying the procedure in the reverse order.

#### 4.2.2 - Procedure with replacement of the electric battery Size 29 -42GR ATM (Fig. 15)

For the size 29 42GR ATM, the electric battery is placed in discharge suction eye of the fan motor.

- Unhook the ATM from its suspension support by following the procedure indicated (See 3.3 – Procedure for dismantling the ATM).
- Mark the number of components connected to the electric battery, and then disconnect these electric wires as well as the quick power supply connector from the electric battery. Do not let the wires touch each other.
- Remove the electric battery (Fig. 15a) from its support (Fig.15b).
- Replace the electric battery and proceed with reassembly by applying the procedure in the reverse order.

**CAUTION:** The Carrier type B and D electronic thermostats are provide with an 8 Amps electric battery relay. Carrier requires an additional protective relay for the electric coils above 1600 Watts.

**CAUTION:** In case of regulator provided by the customer, Carrier recommends the installation of an additional protective relay corresponding to the capacity of the electric battery.

### 4.3 - Water coils

#### 4.3.1 - Procedure for dismantling the water battery (Fig. 16)

**CAUTION:** Before any intervention, it is imperative to cut electrical power supply to the device.

- Unhook the ATM from its support by following the procedure indicated (See 3.3 – Procedure for dismantling the ATM).
- Open the filter access door (Fig. 16a) and remove the filter. Mark the direction of the filter: the side with the seal is positioned against the inner plate of the ATM.
- Unscrew the side plate of the ATM (Fig. 16b) fixed with Torx T20 star screws (side opposite to the non-removable plate).
- Remove the valve casings (Fig. 16c) fixed with Torx T20 star fixing screws.
- Disconnect the hydraulic hoses by unscrewing the G 1/2" rotating nuts. Drain the water from the battery into a container.
- Disconnect the servomotors taking care to mark the cold and hot valves.
- Remove the 2-channel or 3-channel water flow regulator valve body. Depending on the adjustment of the device, the coupling of the 3-channel valve can be provided with a hot/ cold reverser, do not dismantle it.
- Unscrew the rear fixing screws from the inside of the ATM (fig. 16d) and the front fixing screws from the outside (Fig.16e).
- Take out the battery (Fig.16f) taking care not to damage the insulation bonded to the sides of the battery.

For remounting:

- Apply the procedure in reverse order ensuring that all the seals have been changed (new seals put in place) and that the seals of the inlet/outlet connections of the water battery have been made.
- In case of damage, replace the insulation located between the connections of the water battery and the ATM.
- Purge the water battery well during re-intake of water.

**CAUTION:** It is recommended to tighten the valve bodies on the coils with care (15 N.m is sufficient) so as not to damage them.

#### 4.3.2 - Inlet – outlet positions of the water battery (Fig.17)

ATM Water inlets-outlets size 1 / size 2:

- Battery with 2 tubes: Inlet (Fig. 17a) and Outlet (Fig.17b)
- Battery with 4 tubes (optional): Hot (Fig. 17c) and cold (Fig.17a) inlets. Hot outlet (Fig. 17d) and cold outlet (Fig. 17b).

The inlets are G1/2" (15/21) male thread screws meant for flat seals with purges. The outlets are equipped with G1/2" (15/21) rotating nuts meant for flat seals.

**CAUTION:** Correctly follow the direction of flow of water indicated by an arrow on the valve body.

### 4.4 – Optional air filter and access

#### 4.4.1 - Description

The 42GR ATM is equipped with a throwaway filter in accordance with the EN 779 standard. Fire rating of the M1 medium, metal wire framework.

#### 4.4.2 - Replacement of the air filter (Fig.18)

The replacement of the filter can be done through the filter access door (Fig.18a). Follow the direction of the filter (Fig. 18b): the side with the seal (Fig.18c) is positioned against the inner plate of the ATM.

The filter must be changed regularly. The lifespan of a filter is dependent on its soiling, which varies according to its conditions of use.

If a soiled filter is not changed, its load loss increases, it may reject the dust collected and challenge the performances of the 42GR ATM (reduction in air flow).

### 4.5 – Fresh air flow regulator

**IMPORTANT:** When the unit is provided with an air inlet temperature sensor, the constant fresh air flow must not exceed 50 % of the air flow blown through the device at minimum speed.

#### 4.5.1 - Constant fresh air flow regulator

**NOTE:** The operation of the fixed constant fresh air flow regulator 30 m<sup>3</sup>/h (8.3 l/s) requires a differential pressure ranging between 50 Pa and 200 Pa. As for the constant fresh air flow regulator adjustable from 60 m<sup>3</sup>/h (16.6 l/s) to 160 m<sup>3</sup>/h (44.4 l/s), it requires a differential pressure ranging between 70 Pa and 200 Pa.

##### 4.5.1.1 – Fixed constant fresh air flow regulator

This type of regulator enables bringing in fresh air flow from 30 m<sup>3</sup>/h (8.3 l/s -10%, +20%).

Procedure for replacement of the fixed constant fresh air flow regulator:

- Disconnect the flexible fresh air duct (Fig.11a) from the ferrule.
- Replace the constant fresh air flow regulator (Fig.11b).
- Reconnect the fresh air duct to the ferrule.

#### 4.5.1.2 - Adjustable constant fresh air flow regulator

This type of regulator enables bringing in adjustable constant fresh air flow from 60 to 160 m<sup>3</sup>/h (16.6 to 44.4 l/s -10%, +20%).

Adjustable constant fresh air flow regulator can be modified on site by displacement or removal of two plastic restrictions.

##### Procedure for changing or replacement of the adjustable constant fresh air flow regulator:

- Disconnect the flexible fresh air duct (Fig. 11a) from the ferrule.
- Move or remove the two restrictions for passage of air to change the setting (according to Fig.19). In case the regulator is defective, replace the fresh air flow regulator (Fig.11b).
- Reconnect the flexible fresh air duct to the ferrule.

#### 4.5.2 - Variable fresh air flow regulator

The suspension box of the 42GR ATM can be equipped with a variable fresh air flow regulator from 0 to 55 l/s (0 to 200 m<sup>3</sup>/h).

This is connected to the Carrier digital regulator and can control the fresh air flow in two ways:

- Either as a fixed flow by the installer and re-adjustable at will.
- Or depending on the level of CO<sub>2</sub>, in this case, it is controlled by a CO<sub>2</sub> sensor through the Carrier digital regulator (the CO<sub>2</sub> sensor is located in the air intake duct of the suspension box).

**NOTE: In the case of the variable fresh air flow regulator, it is necessary for the upstream pressure in the fresh air duct to be 180 Pa.**

#### 4.6 - Water flow control valves

The valves of 2-channel or 3-channel type have bodies designed to resist an operating pressure of 16 bars.

##### 4.6.1 - Digital servomotor and proportional servomotor (3 points)

For these two types of servomotors, the supply voltage is 230 V AC

*To enable priming of the installation with water, hydraulic balancing of the networks and purging of the units, it will be required to electrically power the servomotors so as to enable the valves to open, either by means of wall-mounted thermostats, or the CTM (Centralized Technical Management).*

##### 4.6.2 - Procedure for replacement of the servomotors (Fig. 20)

The servomotors of the hot and/ or cold water valves can be replaced if any defect is identified.

**CAUTION: Before any intervention on this product, it is imperative to cut the power supply to the unit.**

- Close the isolating valves located on the collectors.
- Disconnect the quick power supply connector of the servomotor (Fig.20a).
- Disconnect the servomotors (Fig.20b). In the case of 4 tube battery, identify and mark the cold valve and the hot valve.
- Proceed with reassembly by applying the procedure in reverse order.

##### 4.6.3 - Procedure for replacement of the valve bodies

**CAUTION: Before any intervention on this product, it is imperative to cut the electrical power supply of the unit.**

- Close the isolating valves located on the collectors.
- Disconnect the hydraulic hoses on the ATM side by unscrewing the G 1/2" rotating nuts. Drain the water from the battery into a container.
- Disconnect the servomotors (Fig.20b). In the case of a battery with 4 tubes, mark the cold and hot valves.
- Remove the 2-channel (Fig. 20c) or 3-channel (Fig.20d) water flow regulator valve body. Depending on the adjustment of the device, the coupling of the 3-channel valve can be provided with a hot/ cold reverser, do not dismantle it.
- Install a new valve body on the battery (put new seals).
- Reinstall the servomotors taking care to see that they are correctly clamped onto the valve body.
- Reconnect the hydraulic hoses by screwing back the G 1/2" rotating nuts. Tighten all the hydraulic connections again, and ensure that all the seals have been changed and put in place (tightening torque: 15 N.m).
- Reconnect the quick power connector of the servomotor (Fig.20a).
- Open the isolating valves located on the collectors and purge the water battery.
- Turn on the device after having ensured that no leakage has occurred.

**CAUTION: During assembly of the new valve body, check whether the direction of passage of the fluid indicated by an arrow on the valve body is followed. In case of assembly in the reverse direction, the valve body will be damaged.**

#### 4.7 - Optional hydraulic hose

Be sure to observe the following radii of curvature:

- Non-insulated hose: 72 mm.
- Insulated hose: 106 mm.



5 - CODING

